

**WANG**

3302

**MATRIX PRINTER**

**Model: 2231W-6**

**Customer Engineering  
Product Maintenance Manual**

**729-0340**

III.C.4.M

**CUSTOMER  
ENGINEERING**

**MODEL 2231W-6  
MATRIX PRINTER**

**PRODUCT  
MAINTENANCE  
MANUAL**

**NOTICE:**

THIS DOCUMENT IS THE PROPERTY OF WANG LABORATORIES, INC.  
INFORMATION CONTAINED HEREIN IS CONSIDERED COMPANY PROPRIETARY  
INFORMATION AND ITS USE IS RESTRICTED SOLELY TO THE PURPOSE OF  
ASSISTING YOU IN SERVICING WANG PRODUCTS. REPRODUCTION OF ALL  
OR ANY PART OF THIS DOCUMENT IS PROHIBITED WITHOUT THE CONSENT  
OF WANG LABORATORIES.

**WANG**

LABORATORIES, INC.

ONE INDUSTRIAL AVENUE, LOWELL, MASSACHUSETTS 01851, TEL. (617) 459-5000, TWX 710 343-6769, TELEX 94-7421

## FOREWORD

It should be noted that schematic 7333 sheet 2 of 3 (page 5-9) shows telecommunication circuits (TC) along with power ON circuits. Although the schematic indicates availability of TC, these circuits are not loaded in manufacturing.

To make this handbook easier to use and save time, the manual was designed in the following manner:

The schematics in Chapter 5 have an 8 1/2" X 11" apron so that their circuitry, when folded out, can be seen in full view while turning text pages as the theory in Chapter 4 is being read. Also, where applicable, the location of test points and electrical adjustments are identified mechanically and electrically on the apron. Waveforms and voltages are also listed when appropriate. Also, the grid system on the schematics is used to quickly locate chips.

Chapter 6, Adjustments, is also specially arranged for your convenience. Illustrations and all pertinent procedures to make adjustments are on the same page or are on facing pages so pages need not be turned to look at the referenced illustrations. Also, some illustrations and procedures are repeated to eliminate or reduce the amount of page turning to locate pertinent procedures or illustrations.

Chapter 8, Illustrated Parts List and Disassembly Procedures, contain the disassembly procedures followed by the parts list and the exploded view foldout drawing. Each exploded view foldout drawing has an 8 1/2" X 11" apron which along with the facing page contains the parts list. This allows the user to perform disassembly procedures by turning text pages while the drawing remains folded out.

## TABLE OF CONTENTS

CHAPTER 1 INTRODUCTION	PAGE
1.1 SCOPE .....	1-1
1.2 DESCRIPTION .....	1-3
1.3 SPECIFICATIONS .....	1-6
CHAPTER 2 INSTALLATION	
2.1 SITE CONSIDERATIONS.....	2-1
2.2 UNPACKING AND PACKING PROCEDURES .....	2-1
2.2.1 UNPACKING (SEE FIGURE 2-1) .....	2-1
2.2.2 PACKING.....	2-3
2.3 SET UP PROCEDURE.....	2-4
2.4 PAPER INSERTION .....	2-5
2.5 PRINT ADJUSTMENT.....	2-6
2.6 CARTRIDGE RIBBON REPLACEMENT .....	2-7
2.7 DYNAMIC CHECKOUT .....	2-8
2.7.1 INITIAL SETUP.....	2-8
2.7.2 LOAD PAPER.....	2-8
2.7.3 SET UP PRINTER FOR OPERATION.....	2-9
2.7.4 RUN PRINTER DIAGNOSTIC (CONFIDENCE TEST).....	2-9
CHAPTER 3 OPERATION	
3.1 CONTROLS AND INDICATORS.....	3-1
3.1.1 CONTROL PANEL (REFER TO FIGURE 2-5) .....	3-1
3.1.2 REAR PANEL (REFER TO FIGURE 2-3) .....	3-2
3.1.3 PRINTER (REFER TO FIGURE 1-1) .....	3-2
3.2 PROGRAMMING PROCEDURES PECULIAR TO THE 2231W-6 PRINTER .....	3-3
CHAPTER 4 THEORY OF OPERATION	
4.1 GENERAL.....	4-1
4.1.1 MECHANICAL DESCRIPTION .....	4-1
4.1.2 GENERAL ELECTRONIC DESCRIPTION .....	4-2
4.2 DETAILED FUNCTIONAL DESCRIPTION.....	4-5
4.3 I/O PORTS.....	4-8
CHAPTER 5 SCHEMATICS	
CHAPTER 6 ADJUSTMENT PROCEDURES	
6.1 INTRODUCTION.....	6-1
6.2 ELECTRICAL ADJUSTMENTS .....	6-2
6.2.1 +5VR ADJUSTMENT.....	6-3
6.2.2 WINDOW STROBE ADJUSTMENT (PULSE WIDTH).....	6-3
6.2.3 WINDOW STROBE ADJUSTMENT (PHASE).....	6-4



## III.C.4.M

6.3	MECHANICAL ADJUSTMENTS .....	6-5
6.3.1	PAPER GUIDE ADJUSTMENT CHECK (Refer to Figure 6-7) .....	6-5
6.3.2	PAPER GUIDE ADJUSTMENT .....	6-5
6.3.3	HEAD ADJUSTMENT ARM CHECK .....	6-6
6.3.4	HEAD ADJUSTMENT ARM ASSEMBLY ADJUSTMENT .....	6-6
6.3.5	STRIKER PLATE AND PLATEN BRACKETS CHECK .....	6-7
6.3.6	STRIKER PLATE AND PLATEN BRACKETS ADJUSTMENT .....	6-8
6.3.7	CARRIAGE DRIVE BELT CHECK .....	6-9
6.3.8	CARRIAGE DRIVE BELT ADJUSTMENT .....	6-9
6.3.9	PRINT HEAD ADJUSTMENT CHECK .....	6-10
6.3.10	PRINT HEAD ADJUSTMENT .....	6-13
6.3.11	RIBBON-CLUTCH ASSEMBLY AND CARTRIDGE GUIDES CHECKS .....	6-15
6.3.12	RIBBON-CLUTCH ASSEMBLY AND CARTRIDGE GUIDES ADJUSTMENTS .....	6-15
6.3.13	REED SWITCHES AND MOUNTING BRACKET ADJUSTMENT CHECK .....	6-17
6.3.14	REED SWITCHES AND MOUNTING BRACKET ADJUSTMENTS .....	6-19
6.3.15	REED SWITCH MAGNET ADJUSTMENT CHECK AND ADJUSTMENT .....	6-20
6.3.16	MAGNETIC RELUCTANCE PICKUP AND TIMING DISK ADJUSTMENT CHECK .....	6-23
6.3.17	MAGNETIC RELUCTANCE PICKUP AND TIMING DISK ADJUSTMENT .....	6-23
6.3.18	PAPER FEED SPROCKETS AND PAPER GUIDE COVER ADJUSTMENT CHECK .....	6-24
6.3.19	PAPER FEED SPROCKETS AND PAPER GUIDE COVER ADJUSTMENT .....	6-24
6.3.20	HORIZONTAL VERNIER CLUTCH (PAPER ADVANCE) ADJUSTMENT CHECK .....	6-25
6.3.21	HORIZONTAL VERNIER CLUTCH (PAPER ADVANCE) ADJUSTMENT .....	6-25
6.3.22	PAPER MOVEMENT GEARS ADJUSTMENT CHECK .....	6-26
6.3.23	PAPER MOVEMENT GEARS ADJUSTMENT .....	6-26

## CHAPTER 7 MAINTENANCE

7.1	INTRODUCTION .....	7-1
7.2	DIAGNOSTICS .....	7-1
7.2.1	OPERATING INSTRUCTIONS .....	7-1
7.2.2	OPERATOR SPECIAL FUNCTION OPTIONS .....	7-2
7.2.3	TEST GROUPS .....	7-3
7.2.4	LOOPING DIAGNOSTICS FOR SCOPING .....	7-9
7.3	PREVENTIVE MAINTENANCE .....	7-10
7.3.1	(QUARTERLY) LUBRICATION .....	7-10
7.4	TROUBLESHOOTING .....	7-11
7.4.1	TROUBLESHOOTING HINTS .....	7-11
7.5	115 VAC/230 VAC CONVERSION .....	7-15
7.6	RECOMMENDED SPARE PARTS LIST .....	7-15
7.7	PRINTER CABLES .....	7-15

## CHAPTER 8 DISASSEMBLY PROCEDURES AND ILLUSTRATED PARTS LIST

8.1	INTRODUCTION .....	8-1
8.2	DISASSEMBLY PROCEDURES .....	8-1
8.2.1	COVER REMOVAL AND REPLACEMENT .....	8-1
8.2.2	HEAD ADJUSTMENT ARM REMOVAL AND REPLACEMENT .....	8-2
8.2.3	HORIZONTAL VERNIER CLUTCH REMOVAL AND REPLACEMENT .....	8-2
8.2.4	PAPER FEED SPROCKETS AND PAPER GUIDE COVER REMOVAL AND REPLACEMENT .....	8-3
8.2.5	LOWER PAPER GUIDE ASSEMBLY REMOVAL AND REPLACEMENT .....	8-5
8.2.6	STRIKER PLATE REMOVAL AND REPLACEMENT .....	8-6
8.2.7	CARRIAGE SERVOMOTOR REMOVAL AND REPLACEMENT .....	8-6
8.2.8	CARRIAGE ASSEMBLY REMOVAL AND REPLACEMENT .....	8-7
8.2.9	CARRIAGE DRIVE TIMING BELT REMOVAL AND REPLACEMENT .....	8-8
8.2.10	SOLENOID AND PRINT WIRE REMOVAL AND REPLACEMENT .....	8-11
8.2.11	REED SWITCHES AND MOUNTING BRACKET REMOVAL AND REPLACEMENT .....	8-14
8.2.12	REED SWITCH MAGNET REMOVAL AND REPLACEMENT .....	8-15
8.2.13	MAGNETIC PICKUPS REMOVAL AND REPLACEMENT .....	8-17
8.2.14	RIBBON DRIVE ASSEMBLY AND CARTRIDGE GUIDES REMOVAL AND REPLACEMENT .....	8-18
8.3	ILLUSTRATED PARTS LIST .....	8-20
8.3.1	COVER ASSEMBLY PARTS LIST .....	8-21/8-22
8.3.2	SHAFT ASSEMBLIES PARTS LIST .....	8-23
8.3.3	RIGHT HAND SIDE FRAME ASSEMBLY PARTS LIST .....	8-24
8.3.4	LEFT HAND SIDE FRAME ASSEMBLY PARTS LIST .....	8-26
8.3.5	PRINT HEAD ASSEMBLY PARTS LIST .....	8-29
8.3.6	CARRIAGE ASSEMBLY PARTS LIST .....	8-30
8.3.7	PAPER GUIDE COVER ASSEMBLY PARTS LIST .....	8-33/8-34
8.3.8	LOWER PAPER GUIDE ASSEMBLY PARTS LIST .....	8-35
8.3.9	CHASSIS ASSEMBLY PARTS LIST .....	8-36

## CHAPTER 9 APPENDICES 9-1

APPENDIX A PAPER SPECIFICATION	A-1
APPENDIX B HEXADECIMAL CODES	B-1
APPENDIX C HEXADECIMAL CODES FOR UNDERSCORED CHARACTERS	C-1
APPENDIX D SIGNAL MNEMONICS	D-1

## LIST OF ILLUSTRATIONS

FIGURE NO.	TITLE	PAGE
1-1	Mechanical Overview of Printer 2231W-6	1-4
1-2	Electrical Chassis Layout	1-5
2-1	Unpacking the Printer	2-2
2-2	Removal of Packaging Tape	2-3
2-3	Rear Panel	2-4
2-4	Head Adjustment/Form Thickness Control	2-6
2-5	Printer's Front Panel	2-9
4-1	Model 2231W-6 System Block Diagram	4-3
4-2	Interface Timing Diagram	4-5
<b>NOTE</b>		
See Section 5 Title Page for Schematic Listing.		
6-1	Timing Disk Alignment Hole	6-2
6-2	Distance Between Carriage and Left Side Frame	6-2
6-3	Timing Disk and Sensors	6-2
6-4	7379 PCB	6-3
6-5	Two Sections of 7332 PCB	6-3
6-6	Scope Presentation	6-4
6-7	Paper Guide Assembly	6-5
6-8	Head Adjustment Arm Assembly	6-6
6-9	Striker Bar Adjustment Check	6-7
6-10	Striker Plate Adjustment	6-8
6-11	Carriage Drive Belt Adjustment	6-9
6-12	Head Bearing	6-10
6-13	Print Head (Exploded View)	6-12
6-14	Print Head (Side View)	6-12
6-15	Bearing Plate for Print Wires	6-13
6-16	Solenoid Identification	6-13
6-17	Carriage Assembly	6-14

6-18	Ribbon Drive Pulley	6-14
6-19	Reed-Switch Checks	6-16
6-20	Magnet to Read-Switch Adjustment Check	6-16
6-21	Reed-Switch Checks	6-18
6-22	Magnet to Read-Switch Adjustment Check	6-18
6-23	Head Adjustment Arm Assembly	6-20
6-24	Removal of the Carriage Drive Belt Pulley	6-20
6-25	Location of Magnet and Allen Head Screw	6-20
6-26	Timing Disk Alignment Hole	6-22
6-27	Distance Between Carriage and Left Side Frame	6-22
6-28	Timing Disk and Sensors	6-22
6-29	Paper Guide Cover	6-24
6-30	Sprocket Cover Pivot Screws	6-24
6-31	Sprocket Adjustment (Disengaged)	6-25
6-32	Sprocket Adjustment (Engaged)	6-25
6-33	Paper Movement Gears	6-26
6-34	Paper Movement Gear Belt Adjustment	6-26
8-1	Cover Assembly	8-21/8-22
8-2	Shaft Assembly Locations	8-23
8-3	Right Hand Side Frame Assembly	8-25
8-4	Left Hand Side Frame Assembly	8-27/8-28
8-5	Print Head Assembly	8-29
8-6	Carriage Assembly	8-31/8-32
8-7	Paper Guide Cover Assembly	8-33/8-34
8-8	Lower Paper Guide Assembly	8-35
8-9	Chassis Assembly	8-37/8-38

**CHAPTER**

**1**

**INTRO-  
DUCTION**

# CHAPTER 1

## INTRODUCTION

### 1.1 SCOPE

This manual describes the Model 2231W-6 Matrix Line Printer. The detailed maintenance information included herein, accompanied by the information in the Customer Engineering Division reprint of the Zilog Z80 manual, should provide the field service engineer with the necessary data for complete support of this microprocessor controlled printer.

### CONTENTS

CHAPTER 1 DESCRIPTION:	A physical description of the printer including specifications.
CHAPTER 2 INSTALLATION:	Unpacking and set-up procedures.
CHAPTER 3 OPERATION:	Contains basic operation of the printer to be used in conjunction with the 2231W-6 Users Manual which provides programming information.
CHAPTER 4 THEORY OF OPERATION:	Explains in detail the theory of the printer's electronic section.
CHAPTER 5 SCHEMATICS:	All electrical drawings and signal run information.
CHAPTER 6 ADJUSTMENT PROCEDURES:	Provides electrical and mechanical adjustment procedures.

### III.C.4.M

#### CHAPTER 7 MAINTENANCE:

Contains preventive maintenance, troubleshooting, and diagnostics.

#### CHAPTER 8 ILLUSTRATED PARTS LIST AND DISASSEMBLY PROCEDURES:

Contains removal and replacement procedures, parts lists and exploded view drawings.

#### CHAPTER 9 APPENDICES:

APPENDIX	A	Paper Specification
	B	Hexadecimal Codes
	C	Hexadecimal Codes for Underscore
	D	Signal Mnemonics

## 1.2 DESCRIPTION

The Model 2231W-6 Matrix Printer is a high-density matrix printer that provides typewriter-like output. The printer uses a high density 12h X 12w or 12h X 24w expanded dot matrix to print an ASCII set of 96 characters containing both upper and lowercase letters, numbers and symbols. Printing at a rate of 60 characters per second, it can generate an output at 30 to 147 lines per minute depending on line length. The Model 2231W-6 prints in a program controlled 10- or 12-pitch format at a standard 6 lines per inch (1/6 inch line feed), however, the line feed may be programmed to a quarter line feed (1/24 inch) for special purposes such as printing subscripts and superscripts. A 132-character buffer receives and stores a full line of data sent from the System Master CPU before the line is printed out. See Figure 1-1 for identification of major mechanical assemblies and see Figure 1-2 for the electrical chassis layout.

### FEATURES

- HIGH DENSITY 12h X 12w DOT MATRIX, NOMINAL.
- 96 CHARACTER ASCII SET
- UP TO 147 LINES / MINUTE CAN BE PRINTED.
- FULL-LINE BUFFER (132 CHARACTERS).
- AUDIO ALARM
- EXPANDED PRINT CAPABILITY. 12h X 24w Dot Matrix
- REMOVABLE CARTRIDGE INK RIBBON.
- FRONT-LOAD AND BOTTOM-LOAD PAPER FEED.
- DESELECTION WITHOUT DATA LOSS.
- LINE FEED SUPPRESSION / TEXT HIGHLIGHTING AND INSERTING ACCENT MARKS OVER CHARACTERS.
- ONE - QUARTER LINE FEED SPACING.
- CHARACTER UNDERSCORING



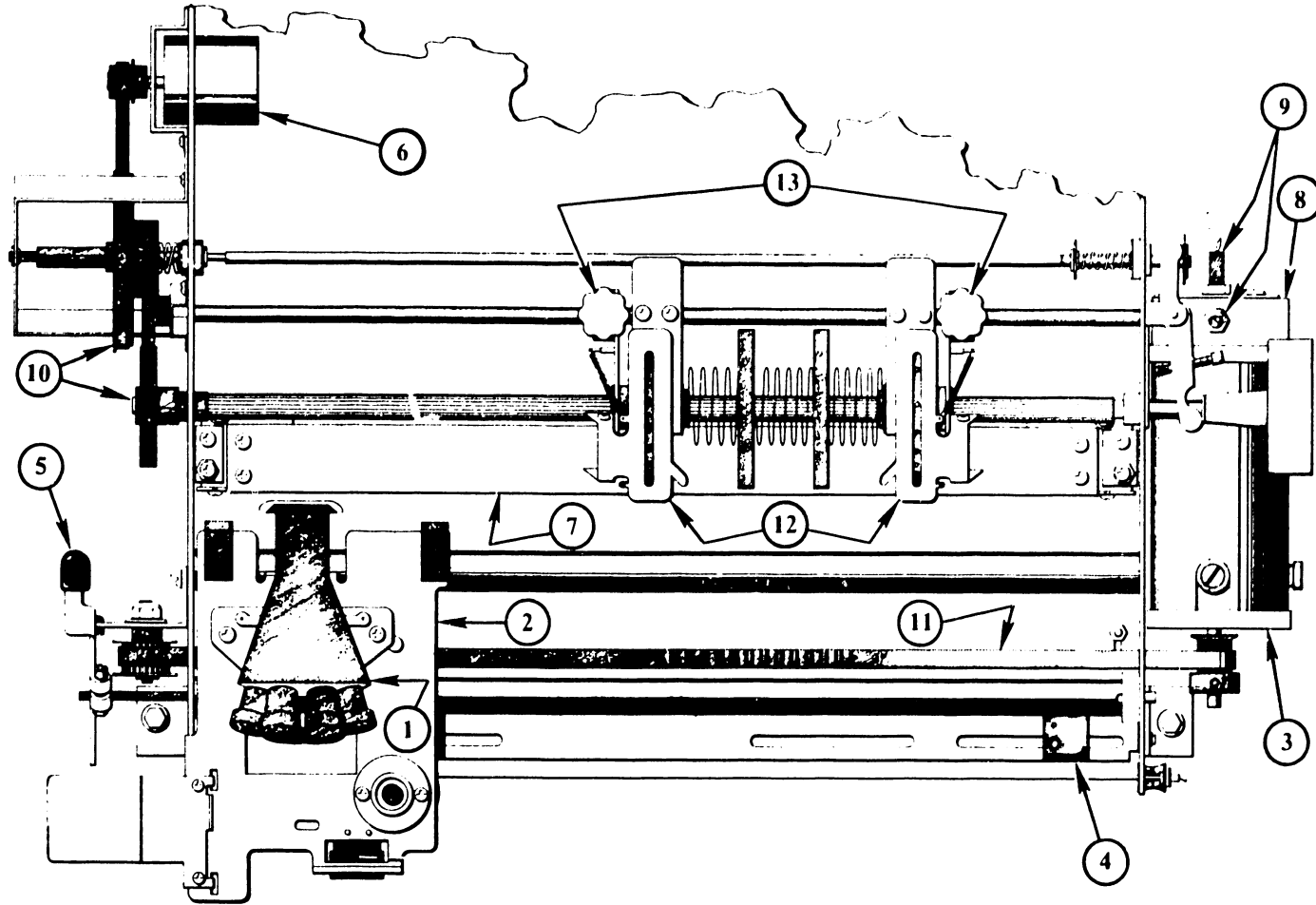

- |                         |                              |                               |
|-------------------------|------------------------------|-------------------------------|
| 1. PRINT HEAD           | 6. PAPER FEED STEPPING MOTOR | 11. CARRIAGE DRIVE BELT       |
| 2. CARRIAGE             | 7. STRIKER PLATE             | 12. PAPER FEED SPROCKETS      |
| 3. CARRIAGE DRIVE MOTOR | 8. ENCODING ADJUSTMENT PLATE | 13. SPROCKET ADJUSTMENT KNOBS |
| 4. MAGNETIC SWITCH      | 9. MAGNETIC PICKUPS          |                               |
| 5. HEAD ADJUSTMENT ARM  | 10. PAPER FEED DRIVE         |                               |

FIGURE 1-1 MECHANICAL OVERVIEW OF PRINTER 2231W-6

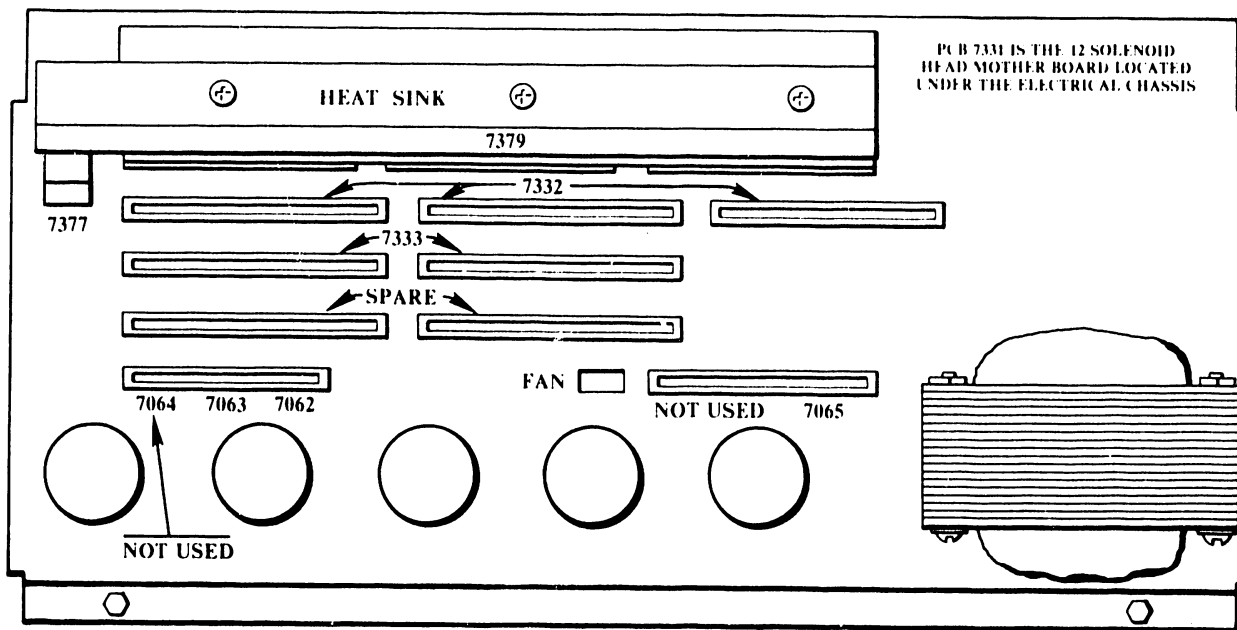

PCB 7331 IS THE 12 SOLENOID HEAD MOTHER BOARD LOCATED UNDER THE ELECTRICAL CHASSIS

- |  |   |
|--|---|
| 7379 - PS REGULATOR BOARD                  | 7063 - REED SWITCH FINGERBOARD          |
| 7332 - MICROPROCESSOR BOARD                | 7062 - PAPER FEED MOTOR FINGERBOARD     |
| 7333 - MEMORY BOARD                        | 7065 - CARRIAGE DRIVE MOTOR FINGERBOARD |
| 7377 - PRINT HEAD RIBBON CABLE FINGERBOARD |   |

FIGURE 1-2 ELECTRICAL CHASSIS LAYOUT

## 1.3 SPECIFICATIONS

### PRINTER SIZE

Height . . . . . 10 inches (25.4 cm)  
Depth . . . . . 18 inches (46 cm)  
Width . . . . . 24 inches (61 cm)

### NET WEIGHT

60 lbs (27 kgs)

### SPEED

60 characters/seconds, 30 to 147 lines/minute

### CHARACTER CONFIGURATION

10- or 12-pitch font controlled by program (defaults to 12-pitch font)  
12h X 12w dot matrix  
12h X 24w dot matrix (for expanded print)

### CHARACTER SET

ASCII 96 characters, both uppercase and lowercase.

### LINE WIDTH

132 characters maximum (66 characters expanded) for 12-pitch format.  
110 characters maximum (55 characters expanded) for 10-pitch format.

### LINE DENSITY

6 lines/inch (nominal).

### RIBBON

Cartridge - ink ribbon; endless, recirculating, Mobius loop.

### SWITCHES/LAMPS/ALARM TONE

ON/OFF, SELECT, LINE FEED, TOP-OF-FORM, CLEAR, FORMS OVERRIDE,  
POWER, PAPER OUT, paper out and power on alarm tone.

PAPER SIZE (EDGE-TO-EDGE)

Adjustable from 3.5 inches (8.9 cm) minimum to 13.5 inches (34.3 cm) maximum. Up to four copies plus original can be printed.

PROGRAMMABLE OPERATIONS

Audio alarm	Form feed
Line feed	Expanded print
Vertical tab	Delete buffer
Carriage return	Quarter-line feed
Line-feed suppression	Underscore
	Top-of-form

CABLE

12 ft (3.66 m) cable with connector to the CPU.

CONTROLLER

Standard Wang Printer Controller/CPU interface.

POWER REQUIREMENTS

115 or 230 Vac  $\pm$  10%  
 50 or 60 Hz  $\pm$  1 Hz  
 1.25/0.65A, 150 Watts

FUSES

ac line: 1.5A (SB) for 115 Vac,  
 8/10A (SB) for 230 Vac  
 dc carriage motor: 2.5A (SB)

OPERATING ENVIRONMENT

50° to 90°F (10° to 32°C)  
 20% to 80% allowable relative humidity  
 35% to 65% recommended

ACCESSORIES

Optional stand

**CHAPTER**

**2**

**INSTAL-  
LATION**

## CHAPTER 2 INSTALLATION

### 2.1 SITE CONSIDERATIONS

Consider the dimensions of the printer with covers open so that the machine will not have to be moved when the ribbon is changed. Also, the ventilation fan-intake screen should not be obstructed by any objects which could reduce normal airflow. For environmental temperature, humidity, etc., see the Technical Characteristics under Specifications in Chapter 1.

### 2.2 UNPACKING AND PACKING PROCEDURES

#### 2.2.1 UNPACKING (SEE FIGURE 2-1)

- 1) Cut the packing straps and remove the box by sliding it up and off.
- 2) Remove the plastic cover from the printer.
- 3) Remove the two 1/2" hex head bolts from top of the plywood base, one on each side of printer. This separates the plywood base/printer combination from the pallet.
- 4) Extend one corner of the plywood over the edge of the table. Remove the 1/2" shipping bolt recessed in that corner on the bottom of the plywood. Follow the same procedure to remove the shipping bolts from the other three corners.
- 5) Slide the printer off the plywood onto the table.
- 6) Remove the tape securing cover of the printer.

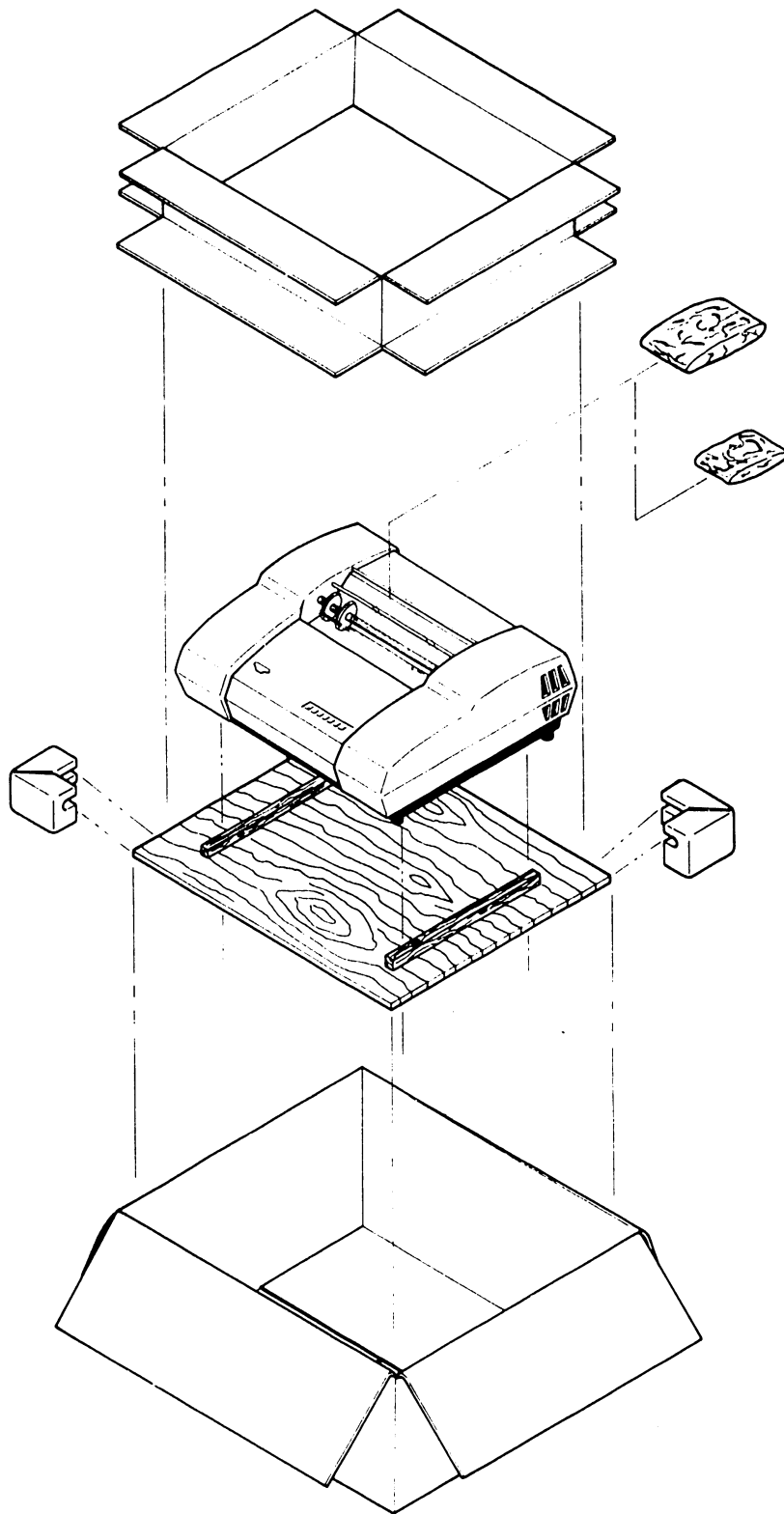
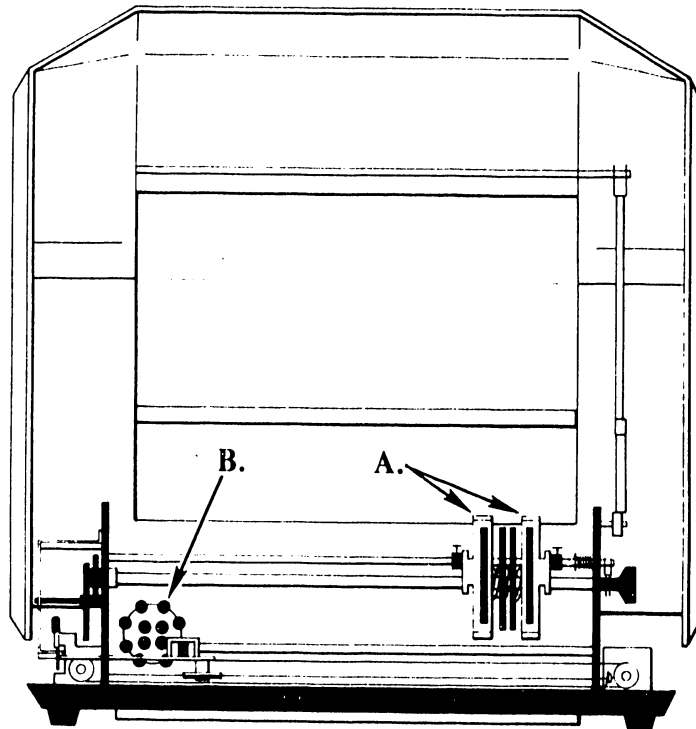

FIGURE 2-1 UNPACKING THE PRINTER

- 7) Open the cover to remove the tape from the following areas:  
(Refer to Figure 2-2).



- A. - LEFT AND RIGHT TRACTOR FEED UNITS
- B. - PRINT HEAD

**FIGURE 2-2 REMOVAL OF PACKAGING TAPE**

- 8) Remove power cord and paper-feed knob from jiffy bag located on top of the rear cover.

### **2.2.2 PACKING**

Reverse steps 2 through 8 of the unpacking procedure above.



## 2.3 SET UP PROCEDURE

- 1) All Printer PCBs must be installed in the electrical chassis and all PCBs must be secured in their connectors (See Figure 1-2).

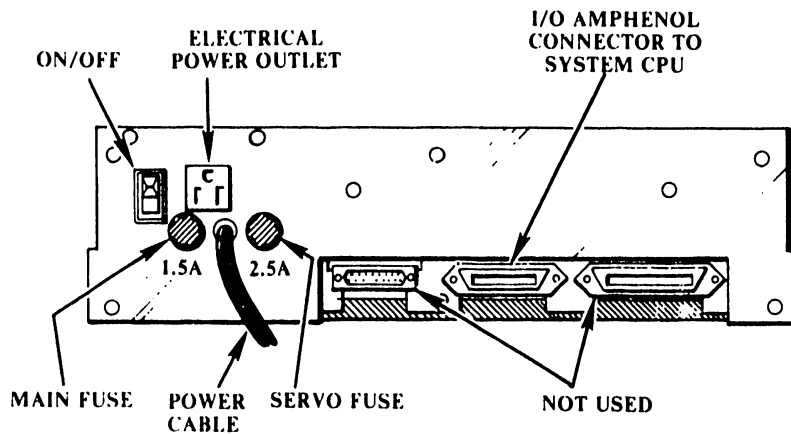

FIGURE 2-3 REAR PANEL

- 2) The 36-pin I/O cable connector must be plugged into the I/O Amphenol connector on the rear panel (See Figure 2-3). The other end plugs into the system CPU.
- 3) The power cord from the Line Printer must be plugged into a grounded wall outlet (see Power Requirements under Specifications in Chapter 1).

## 2.4 PAPER INSERTION

- 1) Raise the cover of the printer. Secure the cover in the raised position with the cover rod located on the right side of the printer.
- 2) Push the continuous-form, pin-feed paper into the slot at the bottom front of the printer until it comes out between the pin-feed mechanisms. (Note: An optional slot for paper insertions is located at the bottom of the printer.)
- 3) Open the pin-feed gates, insert the paper holes evenly over the pins, and close the gates. If the distance between the pin-feed mechanisms must be adjusted, unscrew the right-hand lock knob and slide the mechanism to the proper position. After the paper is in proper position, screw the lock knob and close the cover of the printer.
- 4) Press the ON/OFF Rocker Switch at the rear of the printer. When the printer is ON, the Power Lamp (left indicator of Control Panel) is illuminated.
- 5) Press the LINE-FEED Switch to advance paper in the printer.

### CAUTION

NEVER OPERATE THE LINE PRINTER WITHOUT PAPER.

- 6) If paper runs out while the printer is being used, the system ceases operation, an audible one-second tone is sounded, and the PAPER-OUT Lamp becomes illuminated. To complete printing the page, press FORMS OVERRIDE to print one-line-at-a-time until the paper advances to Top-of-Form position. The paper may now be changed. Press the FORMS OVERRIDE button to continue printing after inserting fresh paper in the printer.

**NOTE**

**DO NOT PRESS CLEAR WHEN CHANGING PAPER; DOING SO ERASES THE CURRENT LINE IN THE PRINTER BUFFER.**

**THE COVER OF THE PRINTER CAN BE OPENED FOR MAKING ADJUSTMENTS TO THE PRINT HEAD (ADJUSTING PRINT-HEAD GAP OR DISENGAGING PAPER AT THE PRINT HEAD).**

**WHEN THE COVER IS OPEN, POWER TO THE CARRIAGE MOTOR IS TURNED OFF; THE PRINT HEAD CAN NOW BE MOVED MANUALLY. ONCE THE COVER IS CLOSED, THE PRINTER IS READY FOR NORMAL OPERATION AND THE HEAD IS POSITIONED ELECTRONICALLY.**

**2.5 PRINT ADJUSTMENT**

To adjust the print blackness for different form thicknesses, follow the procedure detailed below:

- 1) The printer must have paper in it and be turned OFF.
- 2) Raise the cover of the printer and find the Print Head and the Forms Thickness Lever. (See Figure 2-4)

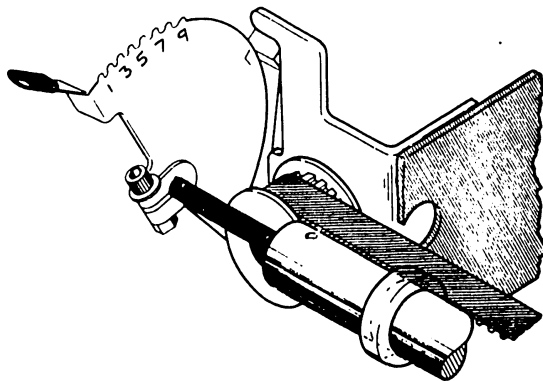

**FIGURE 2-4 HEAD ADJUSTMENT/FORM THICKNESS CONTROL**

**NOTE**

NOTICE THAT THE FORMS-THICKNESS LEVER HAS POSITION NOTCHES MARKED FROM ONE TO NINE FOR DIFFERENT PRINT ADJUSTMENTS. THE LOWER NUMBER POSITIONS ARE FOR SINGLE FORMS; THE HIGHER NUMBERS ARE FOR MULTIPLE FORMS.

- 3) Push or pull the Forms Thickness Lever to move the head in or out; move the lever in to provide a blacker imprint and out to move the head back to accommodate thicker forms.
- 4) When the head has been properly adjusted, close the cover of the printer. (The printer does not operate unless the cover is closed.)
- 5) If during printer operation the paper does not feed smoothly due to its catching on the front surface of the Print Head, check to ensure that the Print Head is properly adjusted and locked in place.

**2.6 CARTRIDGE RIBBON REPLACEMENT**

- 1) Turn power OFF to the printer (rear panel switch).
- 2) Raise the cover of the printer and find the Form-Thickness Lever. Pull the lever completely backward to the "L" (See Figure 2-4) position so that the Print Head is removed from the paper.
- 3) Release spring retainer and lift cartridge up slightly.
- 4) Move control slightly to the rear to disengage ribbon from print-head guide and remove from unit.

### III.C.4.M

- 5) Place the new cartridge in the printer, guide its exposed ribbon over the Print Head while rotating the cartridge spindle as required and snap cartridge in place.
- 6) Readjust Forms Thickness Lever to proper adjustment position.
- 7) Replace the cover of the printer and turn power ON to resume operation.

## 2.7 DYNAMIC CHECKOUT

### 2.7.1 INITIAL SET-UP

- 1) Connect power cord to a 115 or 230 Vac outlet as specified. Be sure that the unit is set-up for the power that is available at the receptacle.
- 2) Connect I/O cable (WL #220-0105-1) to I/O connector on rear of unit and to the connector on controller card 6379/7079 in CPU or the Work Station printer connector.

### CAUTION

NEVER OPERATE PRINTER WITHOUT PAPER

### 2.7.2 LOAD PAPER

- 1) Place printer near and parallel to the front of the table to allow insertion of paper into paper slot.
- 2) Loosen paper margin knobs on pin-feed sprockets and adjust to the appropriate paper width. (See Figure 1-1).

- 3) Slide paper into slot on the bottom or bottom front of the machine. Push it through until it reaches the pin-feed sprockets. Fit the feed holes of the paper into the pin-feed sprockets and close paper-guide covers.

### 2.7.3 SET-UP PRINTER FOR OPERATION

- 1) Set the ON/OFF switch on the rear panel (see Figure 2-3) to ON.
- 2) Depress the SELECT switch on the printer's front panel (see Figure 2-5).

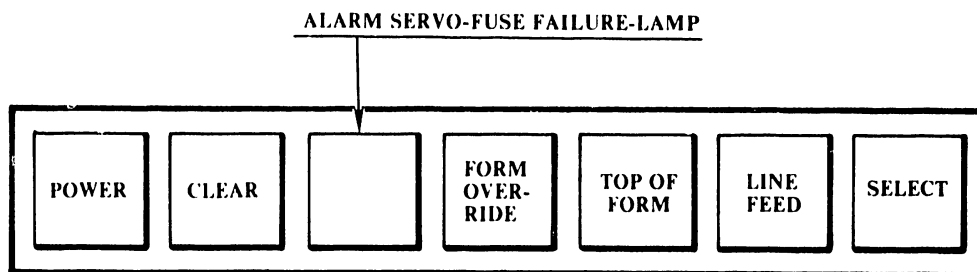

FIGURE 2-5 PRINTER'S FRONT PANEL

### 2.7.4 RUN PRINTER DIAGNOSTIC (CONFIDENCE TEST)

Either the 2200 peripheral diagnostic diskette P/N 701-2180 or the PCS-2 peripheral diagnostic diskette P/N 701-8001 are used to checkout the Model 2231W-6 matrix printer. A complete 2200 system or PCS-2 system is required to run either diagnostic.

The program first asks the operator for the disk address. Once the program knows where the program disk is located, it then loads the Master Menu. This Menu displays the eight options available. No. 1 is the full or System diagnostic. No. 8 is either the Confidence Test or the Design Verification test. Select the Confidence test. For details of diagnostic tests refer to paragraph 7.2.

**CHAPTER**

**3**

**OPERA-  
TION**

## CHAPTER 3 OPERATION

### 3.1 CONTROLS AND INDICATORS

#### 3.1.1 CONTROL PANEL (REFER TO FIGURE 2-5)

- 1) **POWER lamp:** The POWER lamp illuminates and the alarm tone sounds when power is turned on by the ON/OFF switch on rear panel (see Figure 2-3).
- 2) **CLEAR switch:** Clears the input buffer. This momentary switch is enabled only when the printer is deselected.
- 3) **THE ALARM lamp:** The lamp is illuminated to indicate that the servo fuse has blown. (The lamp will only light when the fuse is blown.)
- 4) **FORM-OVERRIDE switch/indicator:** Momentarily overrides the PAPER-OUT switch to allow printing of additional lines of characters on the same page. This momentary switch/indicator illuminates the PAPER OUT indication and an alarm tone is sounded when the paper supply requires replenishing.

#### NOTE

THE PAPER-OUT SWITCH (IN UNIT) OPENS BEFORE ALL PAPER IS USED (ABOUT 1" OF PAPER WILL BE STILL IN THE HOPPER). AT THIS TIME, THE SWITCH DISABLES THE INPUT AND TURNS ON THE AUDIO ALARM FOR APPROXIMATELY ONE SECOND.

WHEN THIS SWITCH OPENS, THE OVERRIDE LAMP BECOMES LIGHTED. IT WILL TURN-OFF WHEN PAPER IS REFILLED OR WHEN FORMS OVERRIDE SWITCH IS MOMENTARILY DEPRESSED.



### III.C.4.M

- 5) TOP-OF-FORM switch: Advances the continuous forms to the top of the next sheet. This switch will not function when unit has been selected by the mainframe system or the SELECT switch on the front panel is illuminated (in the select position).
- 6) LINE-FEED switch: Advances paper vertically one line when momentarily depressed. If held down, paper will advance continuously at one line increments. This switch is disabled when unit has been selected by the system master.
- 7) SELECT switch: Enables input to unit. This momentary switch illuminates when the printer is manually selected.

#### 3.1.2 REAR PANEL (REFER TO FIGURE 2-3)

- 1) ON/OFF switch: Switches power to printer when in the ON position.
- 2) MAIN FUSE: 8/10A slow blow for 230 Vac or 1.5A slow blow for 115 Vac (Fuse for entire unit).
- 3) SERVO MOTOR FUSE: 2.5A slow blow - protects servomotor during paper jam conditions and some logic failures.

#### 3.1.3 PRINTER (REFER TO FIGURE 1-1)

- 1) HORIZONTAL VERNIER KNOB: Advances the paper when manually laterally depressed and turned. To vertically align forms, depress Top-of-Form switch and then manually advance forms for proper alignment.
- 2) PAPER MARGIN KNOBS: Adjust sprockets to paper width.
- 3) HEAD-ADJUSTMENT ARM: The head-adjustment arm adjusts the distance between the print-head bearing and the striker bar. The arm is adjusted for the best print quality (position 1 to 9). To load a new ribbon cartridge, move the Head Adjustment Arm to position L. (See Figure 2-4).

### 3.2 PROGRAMMING PROCEDURES PECULIAR TO THE 2231W-6 PRINTER

In order to increase the flexibility of the 2231W-6 some functions which are constant values on other Wang printers may be programmed into the software on this printer. The codes follow:

1) Pitch

10 pitch      HEX (02), HEX (01)

12 pitch      HEX (02), HEX (02)

- 2) Form Size = HEX (02), HEX (09); HEX (XXYY) XXYY = number of 1/24" increments. The maximum value for form length is three pages, HEX (02090318), which equals a maximum of 792 1/24" increments. Any value greater than three pages is automatically set equal to HEX (02090318) by the printer.
- 3) Auto Form Feed = HEX (02), HEX (0A); HEX (XXYY) XXYY = number of 1/24" increments. The HEX code for auto form feed can be set from (030A0001) to (020A0318). The HEX (0318) code equals the three page 1/24" increment maximum form length. The Auto Form Feed value must always be less than or equal to the value for Form Length.

**CHAPTER**

**4**

**THEORY**

**OF**

**OPERA-**

**TION**

## CHAPTER 4

### THEORY OF OPERATION

#### 4.1 GENERAL

For the detailed Theory-of-Operation of the Z80 microprocessor chip, consult Wang's reprint of the Z80 manual.

##### 4.1.1 MECHANICAL DESCRIPTION

The 2231W-6 Printer uses a matrix-impact-printing technique that generates printed characters with dots in matrix form. The characters are printed by a high-density 12h X 12w dot matrix. The printer operates at a rate up to 147 lines per minute.

Printing is accomplished by firing selected solenoids on the print head as the carriage moves from left-to-right across the paper. When a solenoid is fired, the attached print wire is extended impacting against the ribbon which prints a dot on the paper. Two magnetic reluctance sensors and a timing disk provide electronic signals which are used to control print-head motion and print timing. (See Figure 1-1). A servo motor and three magnetic switches aid in the control of the lateral movement of the carriage.

The printer contains a mobius-strip, fabric-ribbon cartridge. As the print head moves from left-to-right, the ribbon is advanced by a pulley mounted under the carriage. The pulley mechanism disengages from the ribbon cartridge as the carriage returns to the left side of the paper.

As any particular spot on the ribbon passes the print head and re-enters the ribbon cartridge, the looped ribbon is automatically flipped over so that both sides of the ribbon are used as it rotates in one direction.

Continuous-form paper, of widths from 3.5 to 13.5 inches (8.9 to 34.3 cm), can be used in the printer as the distance between the two pin-feed mechanisms is fully adjustable over this range.

### III.C.4.M

A stepping motor, geared to the pin-feed units, is used to vertically advance the paper. The stepping motor is activated by either a carriage return or by program control. It may advance the paper one line or be stopped at the end of a formatted distance of paper advancement. PROMs automatically control the vertical format.

The electronics that control the mechanical movement of the printer are located on printed circuit boards in the rear of the printer. Their functional operation is given in the succeeding paragraphs and their physical layouts are shown in Figure 1-2.

#### 4.1.2 GENERAL ELECTRONIC DESCRIPTION

The "Zilog" Z80 Microprocessor chip is the heart of the 2231W-6 printer. Coupled with the Programmable Read Only Memory (PROM) and the static Random Access Memory (RAM) of the memory board, the Z80 becomes a complete Central Processing Unit (CPU). As indicated in Figure 4-1, the system has an 8-bit, bidirectional, data bus for data processing and a 16-bit unidirectional bus for addressing the various I/O ports and memories. The Z80 performs these and all other functions by stepping through a few basic operations at high speeds, such as memory read or write, I/O device read or write, and interrupt/acknowledge.

The Z80 chip obtains its precise programmed instructions by addressing the 2K PROM. The 8K PROM, when addressed, functions as a character generator. Line-at-a-time printing is accomplished by storing the 132 characters (full line example) in the static RAM memory and feeding this information to the character-generator PROMs (via Z80) which decode and output to the matrix solenoids (via Z80). PROM decoding provides the matrix-solenoid pattern for a given character. The RAM memory will output when 132 characters are present (for a full line) or when a partial line is to be printed. Most last lines of a paragraph are partial lines. The data stored in the RAM memory is strobed in through the PIO 2200/Printer interface port.

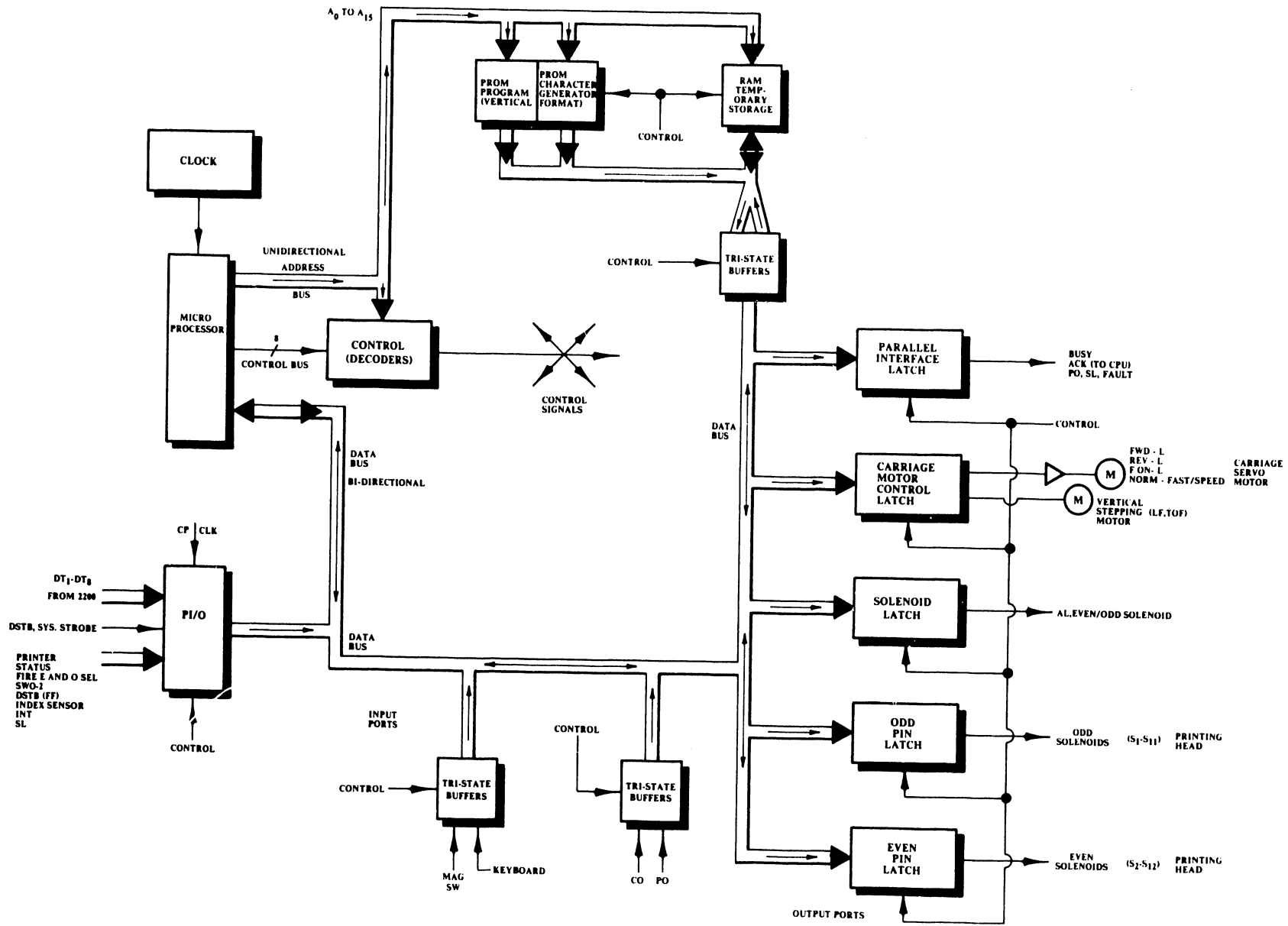

FIGURE 4-1 MODEL 2231W-6 SYSTEM BLOCK DIAGRAM

### III.C.4.M

Carriage-motion loop information is also strobed-in at the PIO interface port (FIRE HO, HE), processed by the Z80, and routed to the Motor Control Output Latch via the 8-bit, bidirectional data bus for input to the differential amplifiers which control the carriage motor. Two magnetic sensors (MPA and MPB) control this motion and are mechanically coupled to the carriage assembly. Magnetic switches SW0, SW1, and SW2) which are strategically positioned along the carriage run provide carriage-position information along with a carriage-speed control signal. They are inputted through a status latch (L10) on the 8-bit, bidirectional bus and processed by the Z80.

Line feed from system control and vertical tab information from the PROMs are processed by the Z80 and then applied to the vertical stepping motor via the motor control latch. This includes vertical tab, top-of-form as well as line feed.

The decoders use the address and control lines from the Z80 to select any of the devices which are connected to the 8-bit, bidirectional bus through tri-state buffers. When one of the input devices is selected, its information can be put on the bus by activating the appropriate tri-state buffer. For instance, the paper out switch can be put on the bidirectional bus and then monitored and processed by the Z80 during one of its instruction cycles. During a succeeding cycle, the Z80 will direct the processed input data to the appropriate output port and light the paper out indicator on the control panel when the paper supply has run out.

While any of these data processing cycles are being performed, a busy signal is being sent to the system master by the printer. An acknowledge signal is also generated to let the system master know that the input data has been received. An interface timing diagram is shown in Figure 4-2.

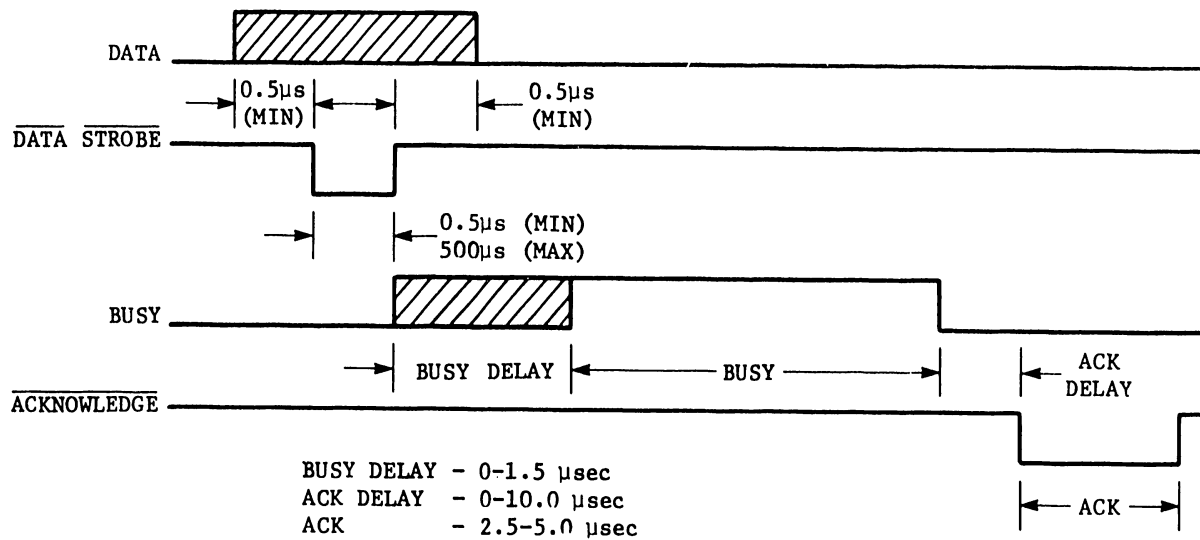

FIGURE 4-2 INTERFACE TIMING DIAGRAM

## 4.2 DETAILED FUNCTIONAL DESCRIPTION

L12 (C,10) of schematic 7332-2 is the input port between the system master and the printer. When L12 is clocked on by the oscillator at pin 25 (CPCCLK), any input data from the system master will be routed to the Z80 for processing via the 8-bit data bus if DSTB is present on pin 16, L12-4 is enabled by decoder L2-6 SEL-L signal (D,8/7332-1) and port A is conditioned by the signals  $A_0$  and  $A_1$  on the address bus, L12-5 & 6 of 7332-2).



### III.C.4.M

Whenever data is strobed into L12 (7332-2), the data strobe FF L8 (D,11/7332-2) is triggered by DSTB at pin 3 from the inverted DSTB from the system master. Data strobe FF L8-5 then provides the system with a high busy through OR gate L21 pin 8 (D,5/7332-1). On the next clock pulse, L12 pin 18 (ARDY) sends a pulse through an inverter/AND gate combination to clear the data strobe FF L8. This action triggers the L14 (E,4/7332-1) oneshot which provides an acknowledge pulse (ACKLG) through an inverter to terminal 10<sub>3</sub> to the system. (See Figure 4-2).

The data that the system puts on the data bus through port A of the PIO is accepted and processed by the Z80. The two types of data that can be processed are printing characters and control characters such as line feed and carriage return. After processing a printable character, the Z80 temporarily stores it in the RAM memory until a line of printing is complete (132 characters for a full line). At this time, the stored RAM printable-character data is processed by the Z80 and routed to the character-generator PROMs which generate a code that causes the Z80 to output the correct pattern of solenoid voltages through the appropriate output port to form the desired printed character.

Port B of the PIO chip is selected by L2-6 and addressed by A0 and A1. Under these conditions, the data input to port B is strobed on to the bus by DSTB FF and processed by the Z80. Similarly to port A data, the resultant processed data is directed to the appropriate output port by the Z80 during a succeeding instruction cycle.

The function decoders L2, L3, and L4 (7332-1) use the Z80 address and control lines to select the appropriate I/O devices on the 8-bit data line PDO-PD7. For example, selecting L33 (D,5/7332-1) allows Z80 to indirectly control BUSY and ACK signals and directly control paper out, fault and select lamps in accordance with Z80 processed inputs during a monitoring or input sequence.

L32 (B,6/7332-1) is the motor control output latch for both the form-feed stepping motor and the carriage-drive servo motor while the L31 (C,3/-7332-1) port controls even and odd enable pulses for the print solenoids along with the alarm and keyboard indicators. L34 and L35 (E,1/7332-1) provide the actual firing pulses to both the even and odd solenoid sets.

The function decoders and address lines also control the input ports. These tri-state buffers put data on the bus so the Z80 can sample and monitor the status of the various printer functions. L10 (F,8/7332-1) when strobed, allows the Z80 to determine the status of some keyboard and carriage motion switches. L9 (G,7/7332-1) and L36 (G,2/7332-1) are the data bus input and output latches respectively which transfer data to and from the memory board.

Double differential amplifier signals from the magnetic pick-up sensors sense the teeth of the timing wheel and index hole. Each tooth in the timing wheel corresponds with one vertical column of the nine in a printed character. The index hole corresponds to the left-hand margin. These signals in the form of index (L27-2), fire HO (L14-7) and fire HE (L27-4) are put on the PDO-PD7 bus by the PIO (C,10/7332-2) to be routed to the Z80. There the information is processed and the resultant data is put back on the bus by the Z80 to be routed to the appropriate output ports such as L32 (C,6/7332-1).

The carriage motion circuits (L15, L25, L26) (G,5,3,1/7332-2) are activated by the Z80 through output port L32. The control signals are FWD-L, REV-L, F-ON-L, and NORM/FAST speed. The differential OP-amps (L25) (G,3/7332-2) and associated components ultimately provide the drive speed and direction signals to the carriage servo motor.

The 7333 memory board contains PROMs L3 through L8 and RAMs L1 and L2. PROM L4 (2K) contains the software or programmed instructions to the Z80 and the remaining 8k of PROMs (L5, L6, L7 and L8) are essentially a character generator by providing the proper code to actuate the appropriate even and odd printing solenoid patterns to print the desired character. The PROMs are also programmed to provide the desired vertical format.

### III.C.4.M

L21 (E,2/7333-1) and L22 (D,3/7333-1) are the memory input and output ports to the 8-bit bidirectional bus. This allows the Z80 to write and read into the RAM memory and read from the PROMs. The address bus and decoders allow entry into the desired portion of memory and the selection of the appropriate chip respectively.

The 7379 board houses a voltage regulator stage type and driver amplifiers. The +5V regulator (L1) is an OP-amp type regulator feeding Q1 which provides +5V regulated to the logic. The -12V and +12V for the memory chips are produced by Q2 and Q3 respectively. These are emitter follower circuits with a zener diode of the appropriate value in the emitter/base region.

The carriage motor is driven forward by Q36 and Q37 (7379) which place +18V on the motor when MO signal at connector K2 is high. For reverse direction Q37 and Q36 place -32V on the motor when MO (K2) is a negative voltage. When MO (K2) is 0V the motor stops.

Solenoid drivers Q23 - Q34 and Q8 - Q19 (7379) supply 0V on one side of the solenoid. The other side is 32V when a high is applied to the inputs S1 - S12. The op amp (L2) amplifies the signals Yo, Yb, Xo, Xb which feed Q20, Q21, Q22 and Q35 in turn driving the power transistors (Q4-Q7) which drive the vertical or form-feed stepping motor.

## 4.3 I / O PORTS

All input ports are three-state buffers, and all output ports are D-type latch FFs which give the lower speed devices time to respond to the control signals.

**CHAPTER**

**5**

**SCHE-**

**MATICS**

THE SCHEMATICS, WHEN AVAILABLE, ARE ON THE LAST FICHE IN THIS SET.

**CHAPTER**

**6**

**ADJUSTMENT  
PROCEDURES**

## CHAPTER 6

# ADJUSTMENT PROCEDURES

### 6.1 INTRODUCTION

This chapter contains the adjustments of the major mechanical assemblies in the 2231W-6 printer.

Prior to the removal and replacement of suspected mechanical components, the mechanical assembly in question should be checked for proper adjustment. Should adjustment check show out-of-tolerance operation, the corresponding adjustment procedure should be performed. Should adjustment fail to correct the problem, part removal and replacement may be necessary. Adjustment and/or alignment procedures should be performed after the assembly procedures of a given mechanical part or assembly.

For many of the subsequent adjustment procedures, the cover of the unit must be removed to gain access to the inside of the printer. The cover is form fitted and can be removed by lifting on the sides.

This adjustment chapter is arranged so that the full adjustment check and/or adjustment procedures are contained on the same page or adjacent pages as pertinent illustrations for ease in performance. Also, some of the illustrations are repeated so that the reader does not have to turn pages when using the procedures.

## 6.2 ELECTRICAL ADJUSTMENTS

Prior to performance of electrical adjustments, check that the mechanical adjustment "first character position" is within the specifications described below:

**NOTE**

Be sure power is removed from unit.

- 1) Place a 0.305" tool rod through the encoder bracket hole (Figure 6-1) and into the timing-disk hole. Check for a distance of  $1.18" \pm 0.01"$  ( $3 \text{ cm} \pm 0.025 \text{ cm}$ ) between the carriage assembly and the left side frame (See Figure 6-2). If out of adjustment, refer to paragraph 6.3.17 for adjustment procedure.

**NOTE**

THE MAGNETIC PICKUP AND THE TIMING DISK SHOULD NOT CONTACT ONE ANOTHER.

- 2) The distance between the edge/face of the timing disk and the pick ups should be consistent along the circumference of the disk with a gap of  $0.005" \pm 0.001"$  ( $0.0127 \text{ cm} \pm 2.5 \text{ mm}$ ) (See Figure 6-3). If out of adjustment, refer to paragraph 6.3.17 for adjustment procedure.

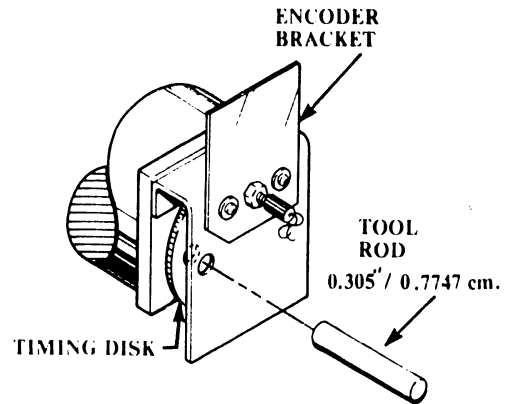

**FIGURE 6-1 TIMING DISK ALIGNMENT HOLE**

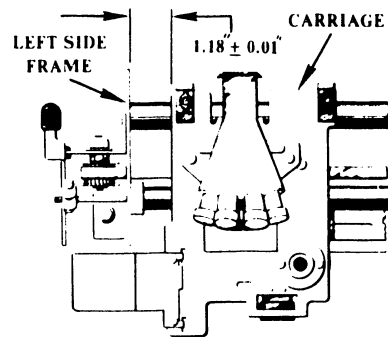

INCHES	CM.
$1.18 \pm 0.01$	$3 \pm 0.025$

**FIGURE 6-2 DISTANCE BETWEEN CARRIAGE AND LEFT SIDE FRAME.**

INCHES	CM.
$0.005 \pm 0.001$	$0.0127 \pm 0.0025$

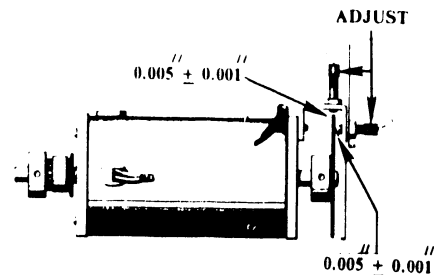

**FIGURE 6-3 TIMING DISK & SENSORS**



### 6.2.1 + 5VR ADJUSTMENT

#### CAUTION

TO PREVENT DAMAGE TO THE PRINT HEAD WHILE MAKING SOME OF THE FOLLOWING ELECTRICAL ADJUSTMENTS, DISCONNECT THE PRINT HEAD ELECTRICALLY BY DISCONNECTING THE FINGER BOARD WHICH PLUGS INTO PRINT HEAD RIBBON CABLE CONNECTOR 7729.

- 1) Turn the printer's power on (rear panel).
- 2) Connect voltmeter + lead to C<sub>1</sub> on 7379 PCB and - lead to  $\pm$  0V. (See Figure 6-4.)
- 3) Adjust R24 (+5VR Pot) until pin C<sub>1</sub> is +5 volts  $\pm$  0.25 volts with respect to  $\pm$  0V.

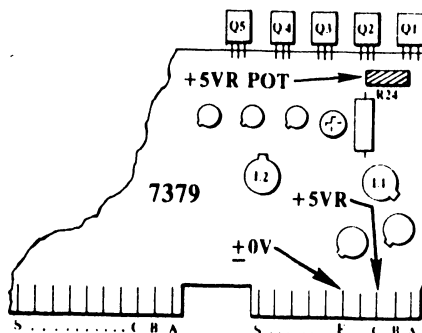
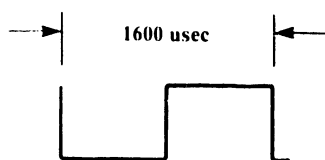

FIGURE 6-4 7379 PCB

### 6.2.2 WINDOW STROBE ADJUSTMENT (PULSE WIDTH)

- 1) Connect scope probe to L27-12 (See Figure 6-5 bottom right half.)
- 2) Adjust scope for negative trigger.
- 3) Adjust 100K pot (R55) for a complete cycle of 1600  $\pm$  25 us at L27-12. (See Below)



- 4) The 50K pot (R22) must be adjusted to obtain a square wave with a 50% duty cycle. (See Below)

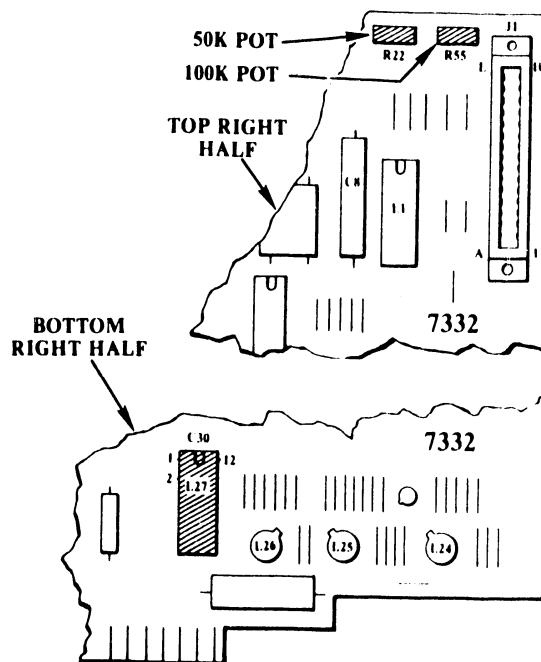
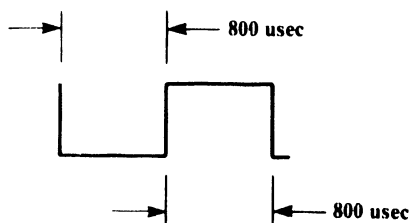

FIGURE 6-5 TWO SECTIONS OF 7332 PCB

### 6.2.3 WINDOW STROBE ADJUSTMENT (PHASE)

- 1) Connect channel 1 probe of scope to L27-2.
- 2) Set scope to positive trigger and use L27-2 as the triggering pulse.
- 3) Connect channel 2 probe of scope to L27-12.
- 4) Loosen mounting plate containing index hole (See Figure 6-1) and adjust for a  $800 \pm 50$  usec between leading edges of pulses. (See Figure 6-6.)

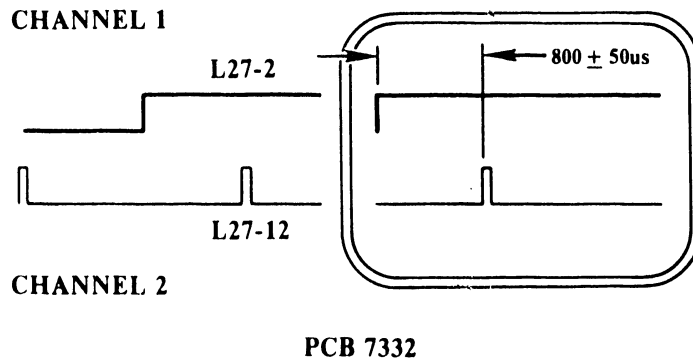

FIGURE 6-6 SCOPE PRESENTATION

- 5) Remove power to printer.
- 6) Connect the print-head fingerboard to the Print-head ribbon cable.
- 7) Secure potentiometers (R24/7379, R22 and R55/7332) with Glyptol after adjustment to prevent any changes due to vibrations in the printer.

## 6.3 MECHANICAL ADJUSTMENTS

### NOTE

TURN POWER OFF TO PRINTER (REAR PANEL SWITCH)  
BEFORE PERFORMING THE FOLLOWING MECHANICAL  
CHECKS AND ADJUSTMENTS.

### 6.3.1 PAPER GUIDE ADJUSTMENT CHECK (REFER TO FIGURE 6-7)

#### NOTE

THE PAPER-TENSION SPRING MUST BE  
PARALLEL TO THE BOTTOM-FEED PAPER  
GUIDE ACROSS ITS ENTIRE LENGTH.  
THE POINT AT WHICH THE PAPER  
EXITS FROM THE PAPER-TENSION  
SPRING SHOULD BE THE ONLY PLACE  
WHERE THE SPRING CONTACTS THE  
BOTTOM-FEED PAPER GUIDE.

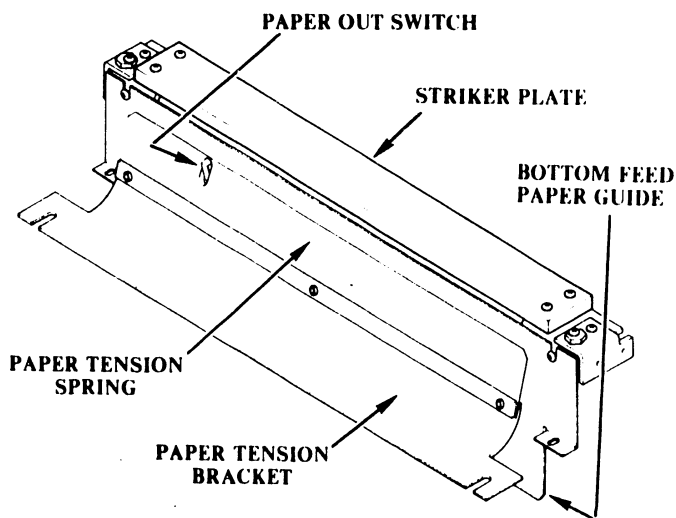

FIGURE 6-7 PAPER GUIDE ASSEMBLY

- 1) Push a piece of paper squarely through the front-feed or bottom-feed paper guides to determine if a slight resistance can be felt along the entire width of paper as the paper begins to appear at the front of the machine.
- 2) As a single sheet of paper is pulled upward through the paper-tension spring, check for a two ounce (57 gram) force required to pull paper to produce movement. (An 8 part form, or 3 sheets of paper, should not bind when pulled through.)

### 6.3.2 PAPER GUIDE ADJUSTMENT

Loosen the two screws holding the paper-tension bracket and move it forward or backward parallel to bottom-feed paper guide to achieve the proper tension (2 oz./57 grams).

### 6.3.3 HEAD ADJUSTMENT ARM CHECK

- 1) Move the head-adjustment arm to position 5 and check that Allen screw in carriage shaft is vertical. (See Figure 6-8.)

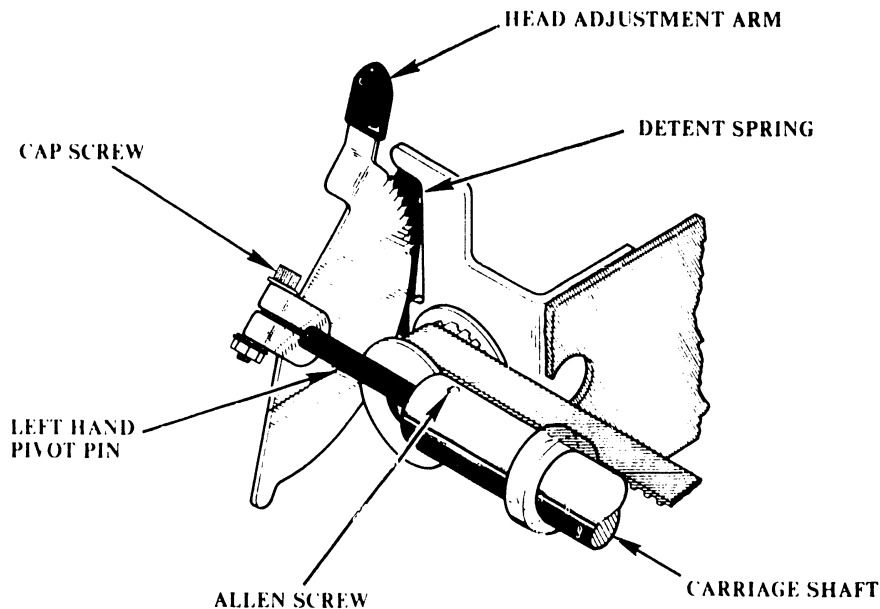

**FIGURE 6-8 HEAD ADJUSTMENT ARM ASSEMBLY**

### 6.3.4 HEAD ADJUSTMENT ARM ASSEMBLY ADJUSTMENT

- 1) Rotate the carriage shaft so that the Allen screw is vertical.
- 2) Loosen the Allen screw holding the left-hand pivot pin.
- 3) Set the head-adjustment arm (on left-hand pivot pin) to position 5, center the arm on the detent spring and tighten the Allen screw.
- 4) Check the striker plate adjustment (paragraph 6.3.5).

## 6.3.5 STRIKER PLATE AND PLATEN BRACKETS CHECK

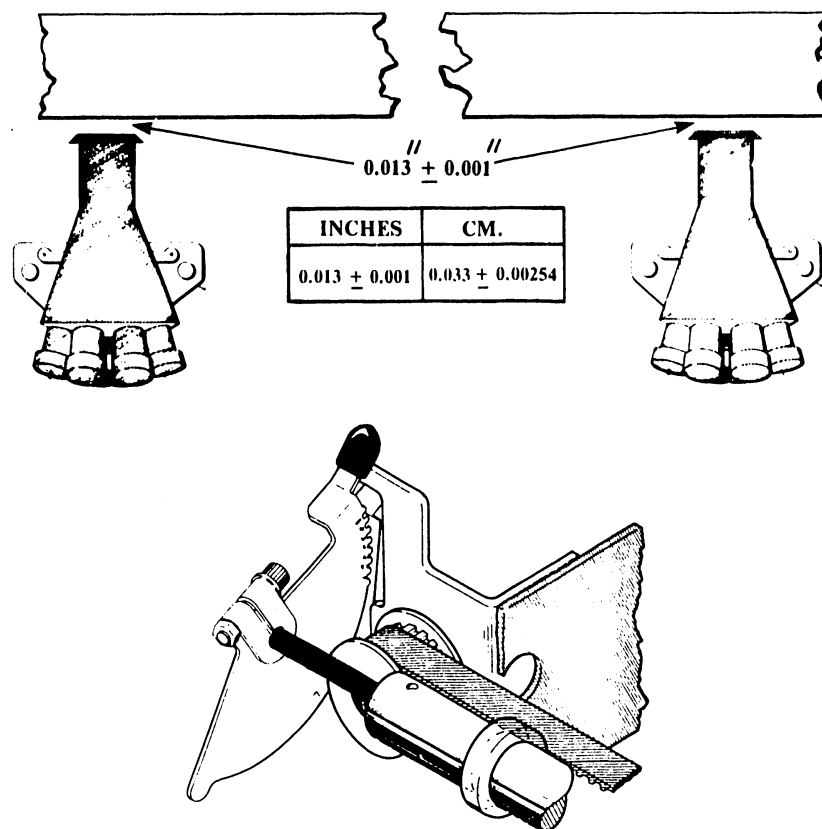

FIGURE 6-9 STRIKER BAR ADJUSTMENT CHECK

- 1) With the print head (see Figure 6-9) in the far left carriage position and the ribbon cartridge removed, move the head-adjustment arm to position 1 (move the print head as close as possible to the striker plate). A 0.013" (0.033cm) gauge should just fit between the striker plate and the face of the bearing.
- 2) Move the head to the far right carriage position and check for the same gap.

## 6.3.6 STRIKER PLATE AND PLATEN BRACKETS ADJUSTMENT

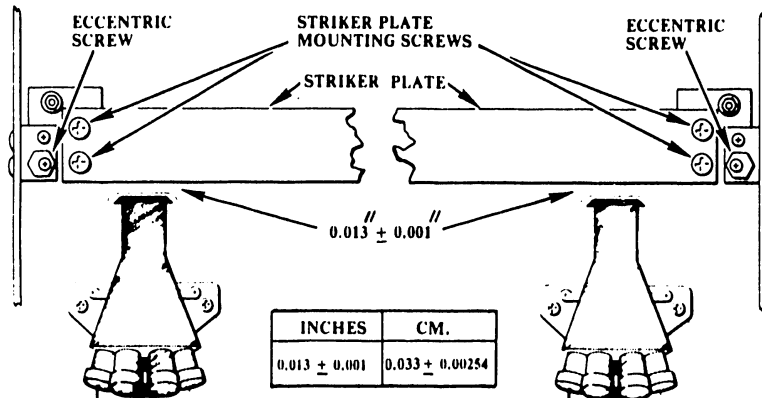

FIGURE 6-10 STRIKER PLATE ADJUSTMENT

## A. FINE ADJUSTMENT

- 1) Move the head-adjustment to position 1.
- 2) Remove the ribbon cartridge from the print head to allow for proper measurement.
- 3) Loosen the four Phillip head screws holding the striker plate to the platen mounting brackets (see Figure 6-10).
- 4) Adjust the striker plate in or out to meet the adjustment of  $0.013" \pm 0.001"$  ( $0.033$  cm) by moving the two eccentric screws. (See Figure 6-10.)
- 5) Tighten the four screws and recheck for proper adjustment.

## B. COARSE ADJUSTMENT

- 1) Loosen the four screws holding the striker plate to the platen-mounting bracket (see Figure 6-10) slide striker plate to front of printer and tighten the four screws.
- 2) Move print head to left side of printer and set head-adjustment arm to position 5.
- 3) Loosen two screws holding platen-mounting bracket on left side frame and adjust in or out for a gap of  $0.013" \pm 0.001"$  ( $0.033 \pm 0.00254$  cm) between striker plate and solenoid wires. Tighten screws. (See Figure 6-10.)
- 4) Repeat step 2 and 3 for right side.
- 5) Check paper guide adjustment (Paragraph 6.3.1).
- 6) Perform the striker plate fine adjustment step 1 to 5 (Paragraph 6.3.6a).

## 6.3.7 CARRIAGE DRIVE BELT CHECK

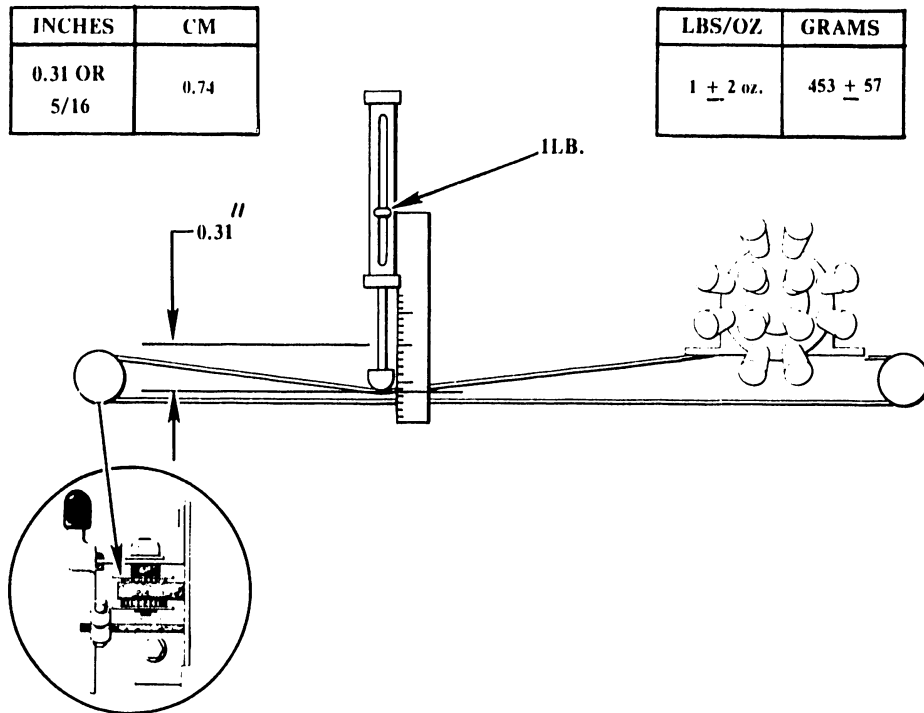

FIGURE 6-11 CARRIAGE DRIVE BELT ADJUSTMENT

- 1) Move the carriage to the extreme right-hand position.
- 2) Using a spring gauge and scale, deflect the middle of the belt 0.31" or 5/16" (0.74 cm). The gauge should read 1 lb ± 2 oz (453 grams ± 57 grams). (See Figure 6-11.)

## 6.3.8 CARRIAGE DRIVE BELT ADJUSTMENT

Loosen the 7/16" nut holding the carriage drive-belt pulley on the left side of the printer (see Figure 6-11). Move the pulley in the desired direction and tighten the pulley nut.

### 6.3.9 PRINT HEAD ADJUSTMENT CHECK

- 1) Loosen the mounting screw holding the 7378-fingerboard retainer and rotate it away from the fingerboard.
- 2) Remove the print head from the carriage assembly by disconnecting the fingerboard from the connector and removing the two print-head mounting screws.
- 3) With a jewelers loupe (magnifier) look at the head bearing (Figure 6-12). All the solenoid wires must be flush with the bearing surface.

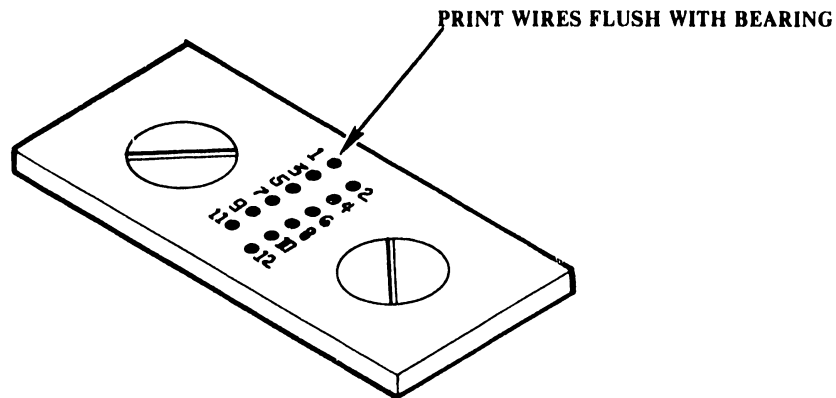

FIGURE 6-12 HEAD BEARING



**PRINT HEAD ADJUSTMENT  
NEXT TWO PAGES**

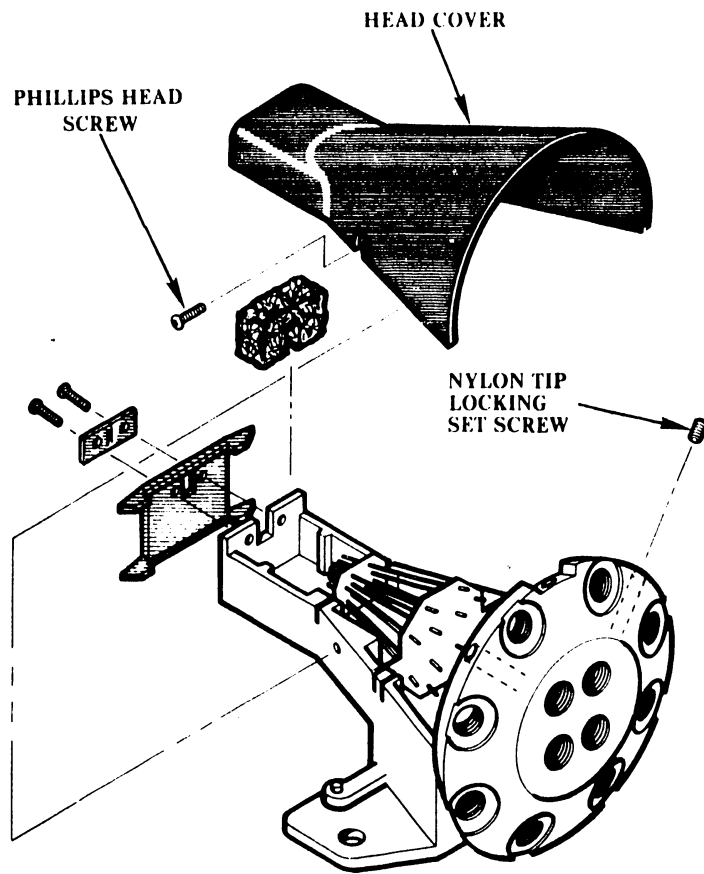

FIGURE 6-13 PRINT HEAD (EXPLODED VIEW)

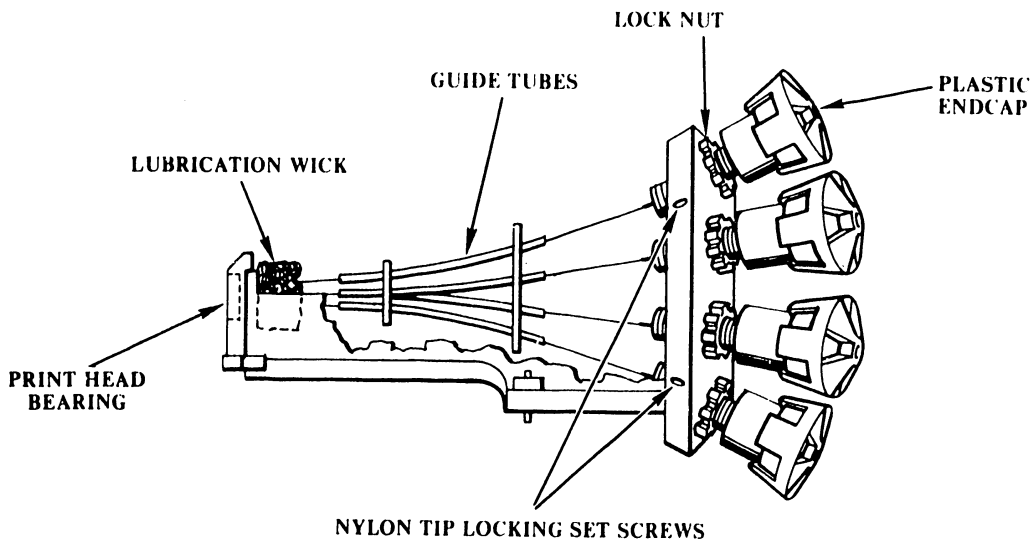

FIGURE 6-14 PRINT HEAD (SIDE VIEW)

### 6.3.10 PRINT HEAD ADJUSTMENT

- 1) Remove the head cover by removing the two Phillips screws. (See Figure 6-13.)
- 2) Unlock the desired solenoid by loosening its corresponding nylon-tip locking set screw (WL #650-4086(8-32 X 15/64)) or lock nut with a solenoid adjustment tool (WL #726-9641).

#### CAUTION

IN STEP 3, WHILE TURNING THE SOLENOID GRASP THE METAL BODY OF THE SOLENOID NOT THE PLASTIC ENDCAP (SEE FIGURE 6-14). USING THE ENDCAP AS A GRIPPING POINT MAY DAMAGE THE COIL WIRES THAT PROTRUDE FROM THE ENDCAP.

- 3) Turn the solenoid to be adjusted (See Figure 6-14) in or out while watching the solenoid wire at the bearing plate (Figure 6-15). All the solenoid wires must be flush with the bearing. Identification of wires and solenoids is shown in Figures 6-15 and 6-16.
- 4) Tighten the nylon-tip locking set screw or lock nut and check bearing again (See Figure 6-14).

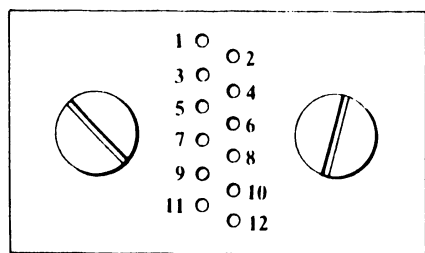

FIGURE 6-15 BEARING PLATE  
FOR PRINT WIRES

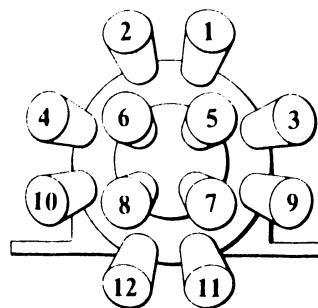

FIGURE 6-16 SOLENOID  
IDENTIFICATION

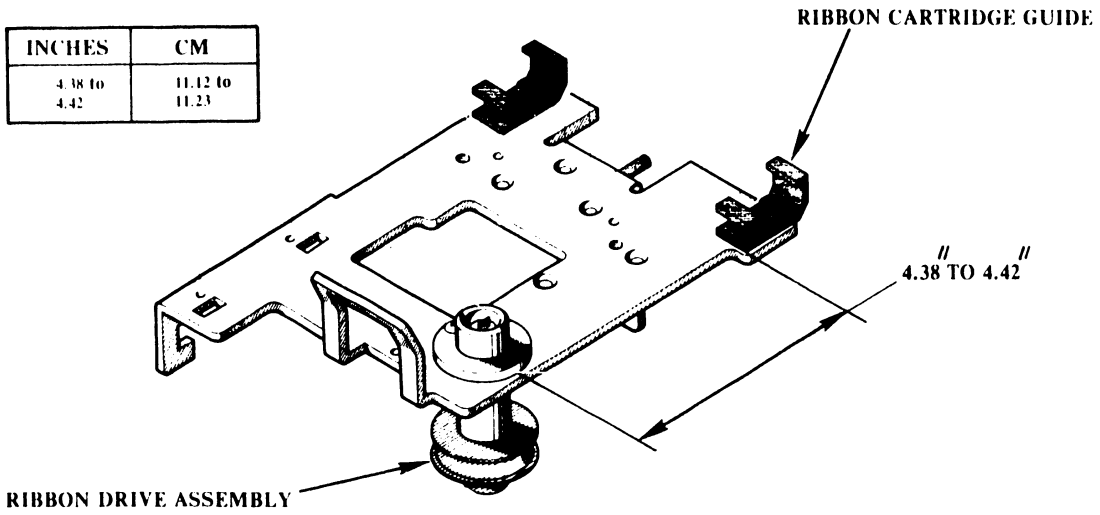

FIGURE 6-17 CARRIAGE ASSEMBLY

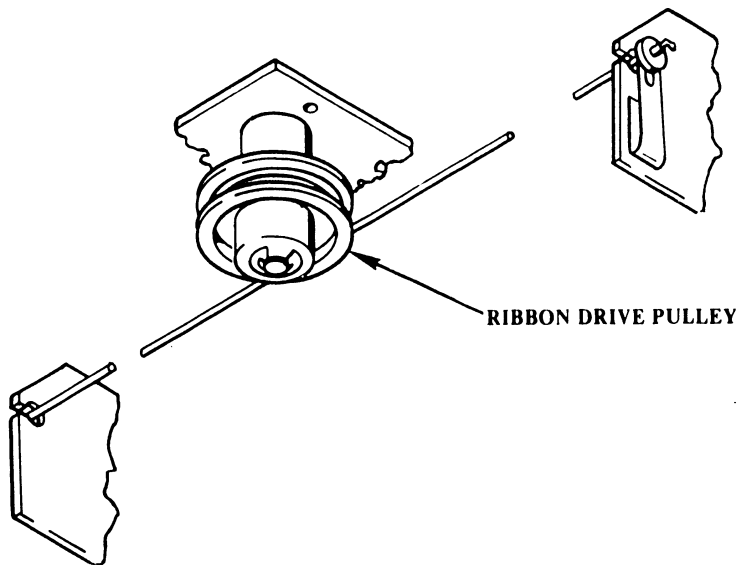

FIGURE 6-18 RIBBON DRIVE PULLEY

### 6.3.11 RIBBON-CLUTCH ASSEMBLY AND CARTRIDGE GUIDES CHECKS

- 1) The distance from the center line of the ribbon-drive assembly to the inside front edge of the ribbon-cartridge guides must be 4.38 to 4.42 inches (11.12 cm to 11.23 cm). (See Figure 6-17.)
- 2) Insert a ribbon cartridge into the ribbon cartridge guides and push down to lock with the ribbon cartridge spring. Check that the ribbon-cartridge does not have to be forced during installation.
- 3) Check that the ribbon-advance cable is properly seated on the ribbon-drive pulley. (See Figure 6-18.)
- 4) The Ribbon cartridge should lift free of the ribbon-cartridge spring with an upward force of 2 lbs  $\pm$  2 oz (907 grams  $\pm$  57 grams) applied to the rear of the ribbon cartridge.

### 6.3.12 RIBBON-CLUTCH ASSEMBLY AND CARTRIDGE GUIDES ADJUSTMENTS

- 1) Loosen the Allen screws and move the ribbon-cartridge guides in the appropriate direction. (See Figure 6-17.)
- 2) Loop the ribbon-advance cable around the ribbon-drive pulley so that the cable is to the rear of the pulley. (See Figure 6-18.)
- 3) Loosen the hex-head screw on the bottom of the carriage and move the ribbon-cartridge spring in the appropriate direction. (See Figure 6-17.)

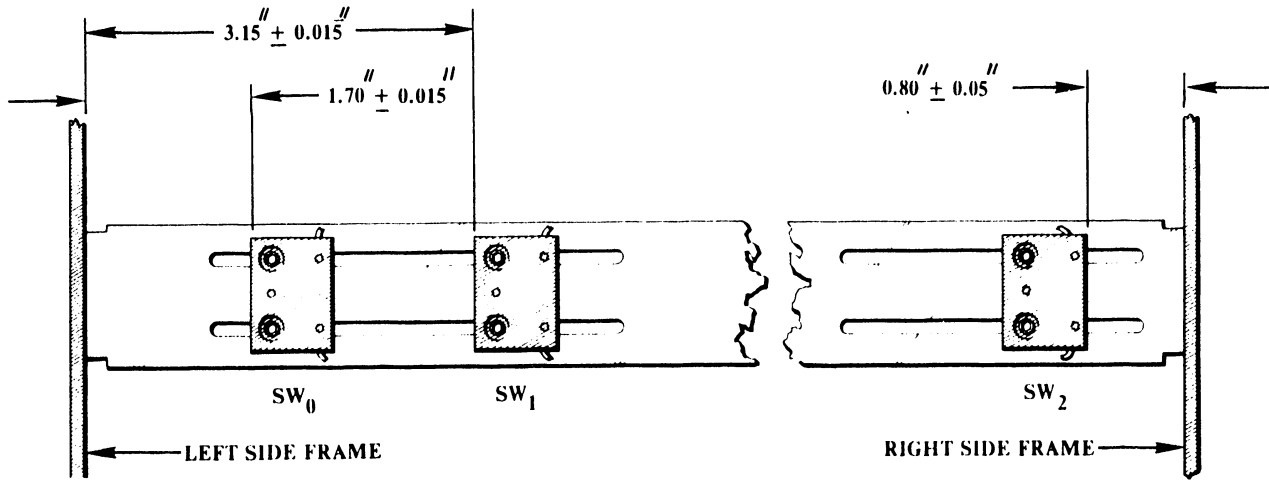

FROM                      TO                      MEASURE

LEFT-SIDE FRAME	LEFT SIDE OF SW <sub>0</sub>	$1.70'' \pm 0.015''$ (4.32cm ± 0.038)
LEFT-SIDE FRAME	LEFT SIDE OF SW <sub>1</sub>	$3.15'' \pm 0.015''$ (8.00cm ± 0.032)
RIGHT-SIDE FRAME	RIGHT SIDE OF SW <sub>2</sub>	$0.80'' \pm 0.050''$ (2.03cm ± 0.127)
REED-SWITCH FRAME	TOP OF SW <sub>0</sub> /SW <sub>2</sub>	$0.060'' \pm 0.015''$ (0.152cm ± 0.038)

**FIGURE 6-19 REED-SWITCH CHECKS**

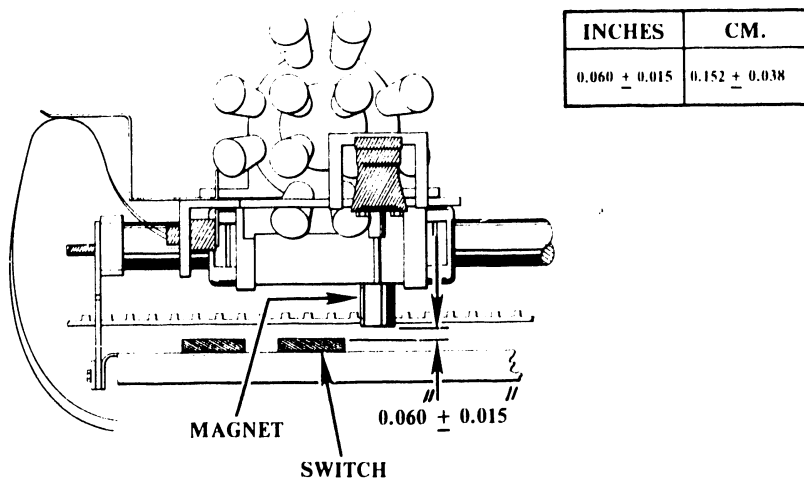

**FIGURE 6-20 MAGNET TO REED-SWITCH ADJUSTMENT CHECK**

### 6.3.13 REED SWITCHES AND MOUNTING BRACKET ADJUSTMENT CHECK

- 1) Check the measurements in Figure 6-19.
  
- 2) A carriage return should occur automatically after a full-buffer condition is generated. This can be accomplished by sending a line of more than 132 characters from the CPU to the printer.

#### NOTE

DURING THE ADJUSTMENT CHECK, IF A REED SWITCH APPEARS TO BE MALFUNCTIONING, SHUT OFF THE POWER. PULL THE REED-SWITCH FINGERBOARD FROM THE ELECTRICAL CHASSIS. PROCEED TO CHECK THE DEFECTIVE REED SWITCH BY USING AN OHMMETER FOR CONTINUITY WHILE MOVING THE CARRIAGE MAGNET OVER THE SUSPECTED SWITCH OR SWITCHES. THE BLACK LEAD ON THE FINGERBOARD IS COMMON TO ALL THREE SWITCHES. THE COLOR CODE FOR EACH SWITCH IS AS FOLLOWS:

SWO (GREEN), SW1 (VIOLET) AND SW2 (WHITE).

#### CAUTION

TURN POWER OFF (REAR PANEL ON-OFF SWITCH).

- 3) WITH POWER OFF, check that a gap of  $0.060" \pm 0.015"$  ( $0.152 \text{ cm} \pm 0.038 \text{ cm}$ ) exists between the reed-switch package and the reed-switch magnet (See Figure 6-20).

III.C.4.M

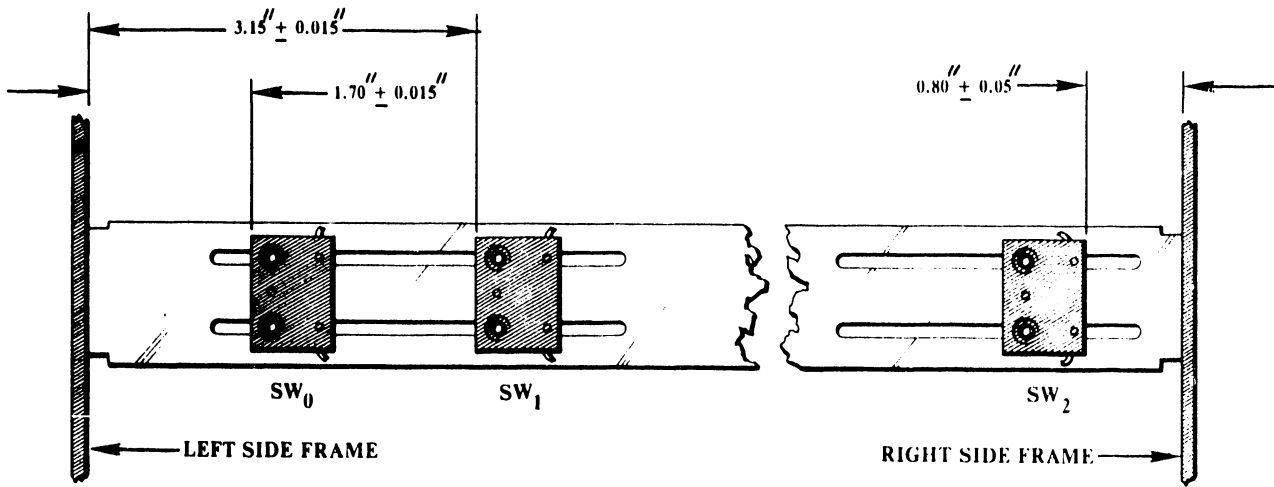

<u>FROM</u>	<u>TO</u>	<u>MEASURE</u>
LEFT-SIDE FRAME	LEFT SIDE OF SW <sub>0</sub>	1.70" ± 0.015" (4.32cm ± 0.038)
LEFT-SIDE FRAME	LEFT SIDE OF SW <sub>1</sub>	3.15" ± 0.015" (8.00cm ± 0.032)
RIGHT-SIDE FRAME	RIGHT SIDE OF SW <sub>2</sub>	0.80" ± 0.050" (2.03cm ± 0.127)
REED-SWITCH FRAME	TOP OF SW <sub>0</sub> /SW <sub>2</sub>	0.060" ± 0.015" (0.152cm ± 0.038)

FIGURE 6-21 REED-SWITCH CHECKS

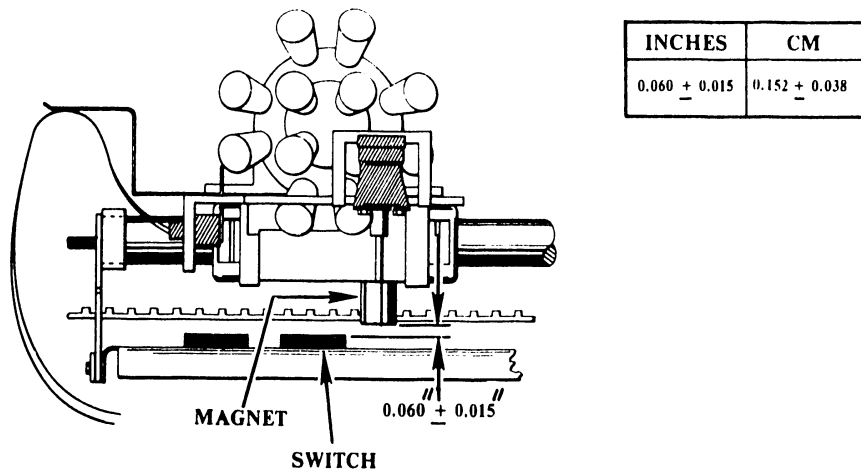

FIGURE 6-22 MAGNET TO REED-SWITCH ADJUSTMENT CHECK



### 6.3.14 REED SWITCHES AND MOUNTING BRACKET ADJUSTMENTS

#### WARNING

BECAUSE THE SCREWDRIVER USED MAY BE MAGNETIC,  
ALWAYS ADJUST THE REED SWITCHES WITH POWER  
OFF. THE ACCIDENTAL CLOSING OF THESE SWITCHES  
COULD BE HAZARDOUS.

- 1) Adjust the reed switches by loosening the screws holding the reed-switch bracket and adjust in accordance with the specifications in Figure 6-21.
- 2) Loosen the four screws holding the reed-switch bracket to both side frames and move the assembly up or down to adjust for  $0.060" \pm 0.015"$  ( $0.152 \text{ cm} \pm 0.038 \text{ cm}$ ) gap between the magnet and the reed-switch packages. (See Figure 6-22.)

**6.3.15 REED SWITCH MAGNET ADJUSTMENT CHECK AND ADJUSTMENT**

**NOTE**

LOOKING FROM THE SIDE OF THE CARRIAGE, THE MAGNET SHOULD BE POSITIONED SO THAT IT PASSES OVER THE SWITCHES. THE SLOT OF THE MAGNET SHOULD FACE IN THE DIRECTION OF CARRIAGE MOTION.

- 1) Remove the ribbon cartridge.
- 2) Loosen the Allen-head cap screw and nut on the head alignment arm and slide it off the end of the pivot pin (see Figure 6-23).
- 3) Remove the carriage drive pulley bracket.
- 4) Using 2-7/16" wrenches, remove the carriage drive-idler pulley from left side of printer.
- 5) Loosen Allen set screws on right and left side of carriage shaft and remove shaft and pins.
- 6) Remove carriage drive belt from servo drive gear (See Figure 6-24).
- 7) Remove carriage stops on carriage shaft and slide carriage off of its shaft.
- 8) Loosen screw in center of magnet.
- 9) Put slot in line of carriage motion and tighten screw (See Figure 6-25).
- 10) Re-assemble unit
- 11) Adjust carriage drive belt tension, head-adjustment arm and striker plate (Paragraphs 6.3.8, 6.3.4 and 6.3.6 respectively).

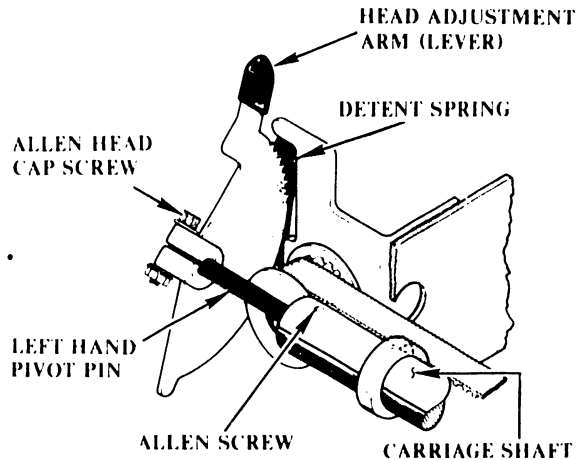

**FIGURE 6-23 HEAD ADJUSTMENT ARM ASSEMBLY**

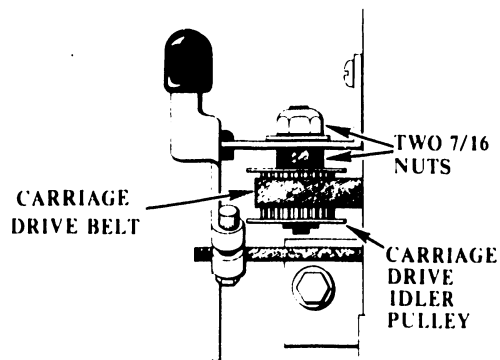

**FIGURE 6-24 REMOVAL OF CARRIAGE DRIVE BELT PULLEY**

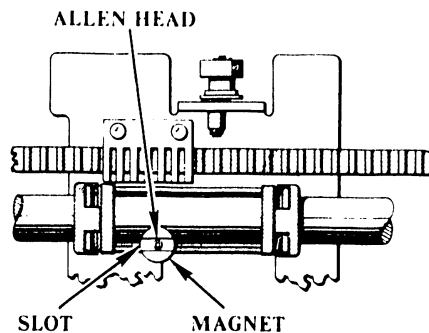

**FIGURE 6-25 LOCATION OF MAGNET AND ALLEN HEAD SCREW**

**MAGNETIC RELUCTANCE PICK UP  
AND  
TIMING DISK ADJUSTMENT CHECK**

III.C.4.M

INCHES	CM.
0.305	0.7747

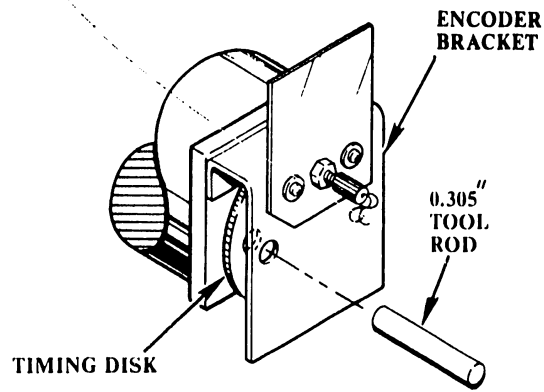

FIGURE 6-26 TIMING DISK ALIGNMENT HOLE

INCHES	CM.
$1.18 \pm 0.01$	$3 \pm 0.25$

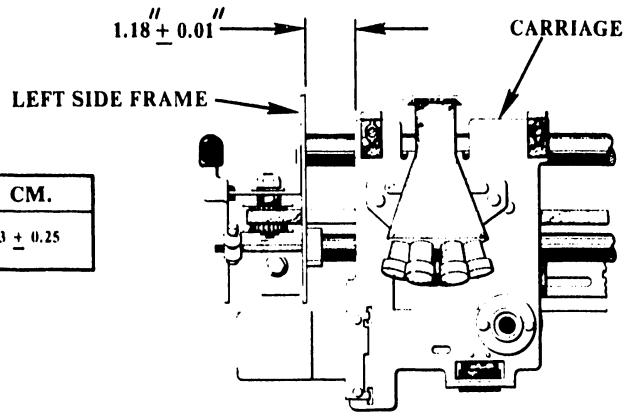

FIGURE 6-27 DISTANCE BETWEEN CARRIAGE AND LEFT SIDE FRAME

INCHES	CM.
$0.005 \pm 0.001$	$0.0127 \pm 0.025$

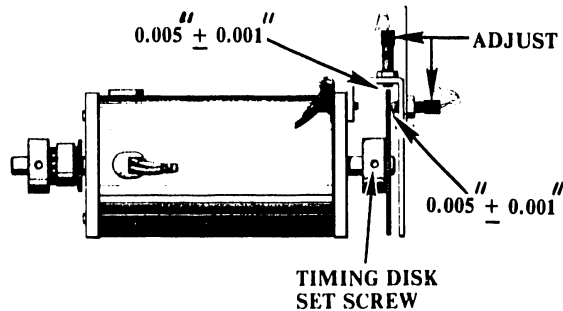

FIGURE 6-28 TIMING DISK AND SENSORS

### 6.3.16 MAGNETIC RELUCTANCE PICKUP AND TIMING DISK ADJUSTMENT CHECK

- 1) Place the 0.305" tool rod through the encoder-bracket hole (see Figure 6-26) and into the timing-disk hole. Check for a distance of  $1.18" \pm 0.01"$  ( $3 \text{ cm} \pm 0.025 \text{ cm}$ ) between the carriage assembly and the left side frame (see Figure 6-27).

#### NOTE

THE MAGNETIC PICKUPS AND THE TIMING  
DISK SHOULD NOT CONTACT ONE ANOTHER.

- 2) The distance between the edge/face of the timing disk and the pick ups should be consistent along the circumference of the disk with a gap of  $0.005" \pm 0.001"$  ( $0.0127 \text{ cm} \pm 0.025 \text{ cm}$ ). (See Figure 6-28.)

### 6.3.17 MAGNETIC RELUCTANCE PICKUP AND TIMING DISK ADJUSTMENT

- 1) Loosen the timing disk set screw (See Figure 6-28), and slide the 0.305" tool rod through the encoder-bracket hole and into the timing-disk hole. (See Figure 6-26.)
- 2) Move the carriage  $1.18" \pm 0.01"$  ( $3 \text{ cm} \pm 0.025 \text{ cm}$ ) from the left side frame and tighten the timing-disk set screw (refer to Figures 6-27 and 6-28).
- 3) Loosen the index hole magnetic reluctance pickup locking nut. (See Figure 6-28.)
- 4) Back out the pickup and place a 0.005" (0.0127 cm) gauge between the pickup and the timing disk. Turn the pickup in until it just contacts the gauge and retighten the locking nut. (Refer to Figure 6-28.)

### III.C.4.M

#### 6.3.18 PAPER FEED SPROCKETS AND PAPER GUIDE COVER ADJUSTMENT CHECK

- 1) With each of the sprocket-wheel covers closed, there should be a gap between the cover and the paper-feed sprocket of 0.025" to 0.039" (0.064 cm to 0.076 cm) (See Figure 6-29.)
- 2) The teeth of the sprocket should be centrally located in the cover slot 0.030" as shown in Figure 6-29.

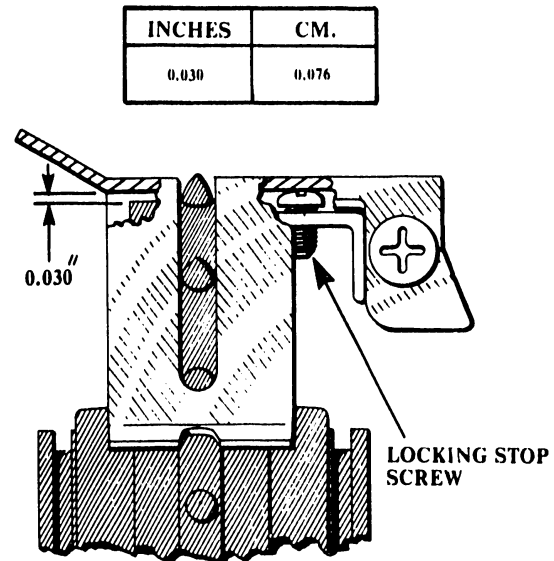

FIGURE 6-29 PAPER GUIDE COVER

#### 6.3.19 PAPER FEED SPROCKETS AND PAPER GUIDE COVER ADJUSTMENT

- 1) Adjust cover height with the locking-stop screw. Move screw down until a 0.030" (0.076 cm) gauge begins to pinch between the cover and the rubber of the sprocket (see Figure 6-29).
- 2) Adjust the sprocket-cover pivot screws (2) to center teeth (see Figure 6-30). This must be done to both of the paper-guide assembly covers. The pivot screws act as eccentrics to center the cover.

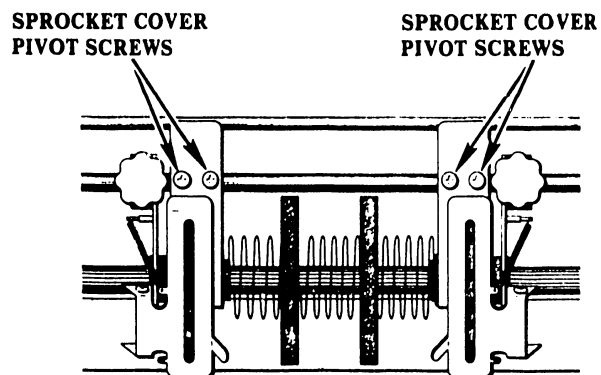

FIGURE 6-30 SPROCKET COVER  
PIVOT SCREWS

### 6.3.20 HORIZONTAL VERNIER CLUTCH (PAPER ADVANCE) ADJUSTMENT CHECK

- 1) By using the horizontal vernier knob, push the vernier clutch in and out. With the use of a feeler gauge check for a clearance of  $0.032'' \pm 0.007''$  ( $0.081 \text{ cm} \pm 0.018 \text{ cm}$ ) between the idler gear and the cone gear as shown in Figure 6-31. Also, when the knob is released after paper advancement, the vernier clutch should fully reengage flush with gear surface as shown in Figure 6-32.

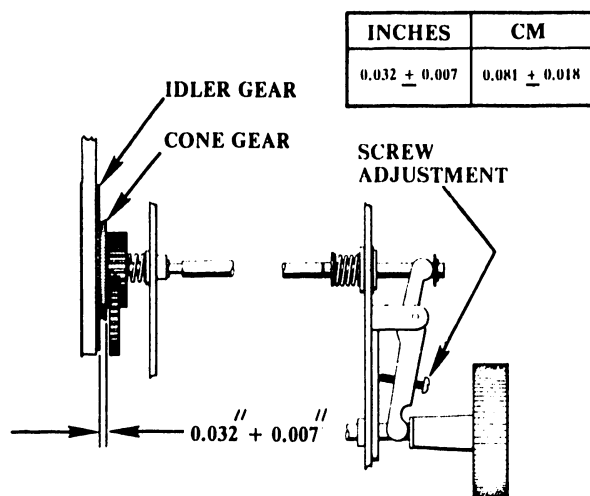

FIGURE 6-31 SPROCKET  
ADJUSTMENT  
(DISENGAGED)

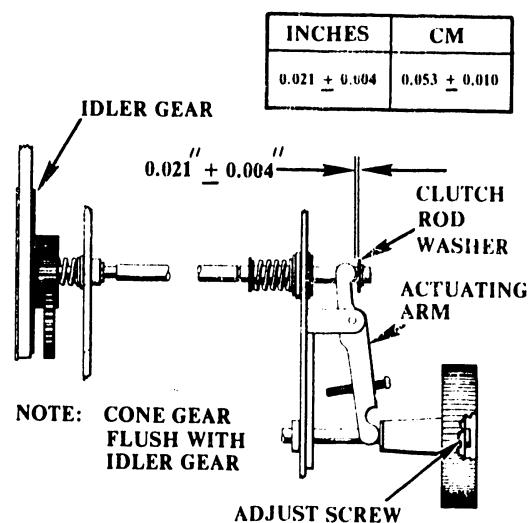

FIGURE 6-32 SPROCKET  
ADJUSTMENT  
(ENGAGED)

### 6.3.21 HORIZONTAL VERNIER CLUTCH (PAPER ADVANCE) ADJUSTMENT

- 1) With the clutch engaged (automatic advance) adjust the Allen screw in the center of the horizontal vernier knob for a gap of  $0.021'' \pm 0.004''$  ( $0.053 \text{ cm} \pm 0.010 \text{ cm}$ ) between the actuating arm and the clutch-rod washer (see Figure 6-32).
- 2) With the clutch disengaged (manual advance), adjust the screw on the actuating arm for a  $0.032'' \pm 0.007''$  ( $0.081 \text{ cm} \pm 0.018 \text{ cm}$ ) gap between the cone gear and the idler gear (see Figure 6-31). (This screw can be adjusted through the hole in the horizontal vernier knob.)

### III.C.4.M

#### 6.3.22 PAPER MOVEMENT GEARS ADJUSTMENT CHECK

- 1) Check the paper sprocket-drive gear for maximum backlash of 0.030" (0.076 cm) (see Figure 6-33), by holding the intermediate gear immobile. (See Figure 6-34.)
- 2) With Stepping Motor Timing Belt depressed 0.1" (0.25 cm), the scale should read 1 lb (453 grams). (See Figure 6-34.)

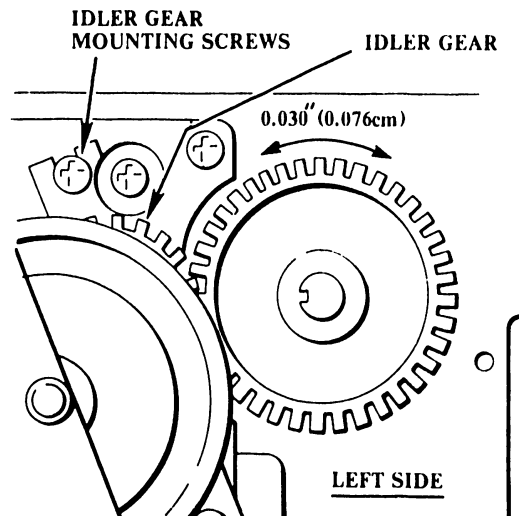

FIGURE 6-23 PAPER MOVEMENT GEARS

#### 6.3.23 PAPER MOVEMENT GEARS ADJUSTMENT

- 1) Loosen the two idler-gear mounting screws (see Figure 6-33) to adjust gear-train backlash for a maximum of 0.030" (0.076 cm).
- 2) Loosen the four screws (see Figure 6-34) holding the stepping motor to the motor bracket. Move the motor in appropriate direction for a 0.1" (0.25 cm) belt depression (a scale reading of 1.0 lb) and tighten the four screws for correct timing belt tension.

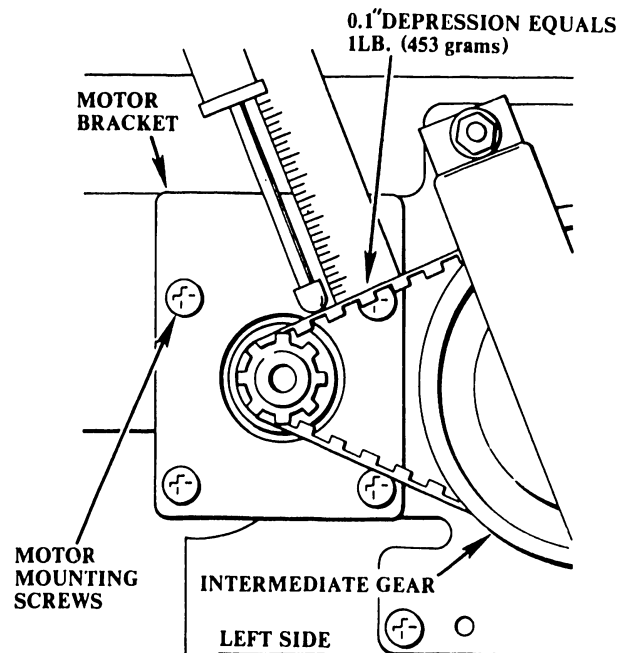

FIGURE 6-34 PAPER MOVEMENT GEAR BELT ADJUSTMENT



**CHAPTER**

**7**

**MAINT-  
ENANCE**

## CHAPTER 7

# MAINTENANCE

### 7.1 INTRODUCTION

This chapter of the manual contains the diagnostics, preventive maintenance, troubleshooting, power conversion procedure, recommended spare parts list, and a list of printer cables.

### 7.2 DIAGNOSTICS

The 2231W-6 diagnostic dated 9/26/78 (2200 P/N 701-2180 or PCS-2 P/N 701-8001 peripheral diagnostic diskette) will checkout all of the internal and external hardware items necessary to ensure that the 2231W-6 printer related functions do perform according to printer specifications. This diagnostic is also a forerunner to a Master 2200 System Printer Diagnostic.

The operator has the option to run any individual group of tests or any individual test over and over again. He also has the option to select either a Confidence Test (short version) or full Design Verification Test. The Confidence Test is a condensed version of the Design Verification Test. It is a quick check to see if the printer is functioning properly.

The Design Verification Test is a complete diagnostic designed to verify all the printer's specifications. It is approximately four times longer than the Confidence Test.

#### 7.2.1 OPERATING INSTRUCTIONS

The program first asks the operator for the disk address that defines where the program disk is residing. Once the program knows where the program disk is residing it then loads the Master Menu. The Master Menu displays the eight different options available as follows:

- |  |                            |
|--|----------------------------|
| 1 - Full Diagnostic/both Confidence<br>and Design Verification Test Menu | 5 - Print Consistency Menu |
| 2 - Data Buffer Menu   | 6 - Special Features Menu  |
| 3 - Character Set Menu   | 7 - Operator Action Menu   |
| 4 - Paper Motion Menu  | 8 - Program Option Menu    |

### III.C.4.M

Option No. 1 calls up the full Diagnostic. Options 2 through 7 call up (fetch) the individual test group menus from the disk. Option No. 8 selects either the Confidence Test or the Design Verification Test.

A good example is when Option 4 (paper motion) is selected. The following will be displayed:

- 1 - All paper motion subtests
- 2 - Line feed tests 1 & 2
- 3 - Vertical tabulation test
- 4 - End of Document test
- 5 - Carriage return test 10 pitch
- 6 - Carriage return test 12 pitch

If subtest 1 is selected, the program will continually loop from subtest 2 through 6. If either subtest 2, 3, 4, 5 or 6 is selected the program will loop on that individual test repeating it over and over again.

#### 7.2.2 OPERATOR SPECIAL FUNCTION OPTIONS

There are three Special Function keys that the operator will use from time to time.

#### NOTE

**TO EXECUTE THESE SPECIAL FEATURE OPTIONS,  
THE OPERATOR MUST FIRST DEPRESS HALT/STEP  
AND THEN THE DESIRED SPECIAL FUNCTION KEY:**

- SF-0 Master Menu Display
- SF-16 SLB Menu Display
- SF-15 Program Restart

- 1) Special Function Key 0 - Master Menu

This key will display the Master Program Menu on the CRT.

2) Special Function Key 16 - Sub Menu 3

This Special Function key will display the current submenu (test) of the group that is presently being tested.

3) Special Function Key 15 - Program Restart

This Special Function key will restart the current program that is in memory at that time.

### 7.2.3 TEST GROUPS

The diagnostic is broken down into six major groups:

- 1- Data Buffer
- 2- Character Set
- 3- Paper Motion Group
- 4- Print Consistency Group
- 5- Special Features Group
- 6- Operator Action Group

1) Data-Buffer Group

This group is set-up in such a way that there are any number of data tests that can be performed. In this diagnostic there are six different tests that can be performed:

The first two are data buffer and data bus characters that will detect if any of the printer data lines are malfunctioning.

The other four tests are the spiral pattern. The spiral pattern is designed to ensure that all the characters can be printed from all 132 printer buffer locations.

### III.C.4.M

#### 2) Character Set Group

There are two sections in this group, one for printing the Design Verification character set, and one for printing the Confidence test character set.

In the Design Verification test the printer displays the hex code and beside it the printer displays in ()'s three of those printable hex codes. Hex 21 (!!!). Therefore, the operator can visually check for the correct character formation and verify that the printer is in fact sending the proper character. This section will display the normal character size and then will display the expanded size character. If the printer is testing under the Confidence Test mode, this section will display that this test is strictly for "Design Verification testing only".

The Confidence Character Set Mode is utilized only during the Confidence Test phase. It will display "Confidence Testing only" when the program is performing the Design Verification Test.

This section will also print out the full 96 character set but will not identify any of the characters. It will print 16 characters-per-line and it prints 5 lines of data. The first line will be characters from a hex(20) to a hex(2F) symbol.

The second line will be hex (30) to a hex (3F). This will continue until the last row of characters has been printed (hex 70 to 7F), numbers and symbols.

The delete code is a special hex code character used to delete or clear the print buffer and control codes. When this program is running and the delete code is functioning properly, there will be an indication of this function. If the delete code is malfunctioning or is not coded properly, then the following message will appear on the print out, "Error - with delete code XX" and XX will be the hex value for the delete code in use.

3) Paper Motion Group

This test group contains the following five different subgroups:

- 1 - Line Feed Test 1 & 2
- 2 - Vertical Tabulation Tests
- 3 - End of Document (EOD)
- 4 - Carriage Return Test 10 pitch
- 5 - Carriage Return Test 12 pitch

The primary function LFT NO. 1 (Line Feed Test #1) is to actuate the mechanical line-feed mechanism and verify its operation. The program prints a reference asterisk and then sends out those line feed hex codes (0A). At a glance the operator should be able to check for errors such as dropped line feeds or added line feeds (hex-0A's). The asterisks should be evenly spaced down the page.

Line Feed test No. 2 exercises the line-feed mechanism as does Test One. It sends a reference line of print, then it sends a given number of line feed hex codes (0A). It is in this test, that lined paper is primarily used. NOTE: There are 32 (2 character lines) per page. AGAIN, if the top-of-form was properly set, any given reference will fall at the same point down the page. The reference mark falls just above the horizontal reference line. If the paper was properly set up, it would have fallen directly on the center line of the page. Therefore, the operator at a glance can see if any one of the reference marks are out of place. If they are, then there is some sort of problem with the paper-motion mechanism.

The Vertical Tabulation Test prints the test title and then it sends a vertical tab (hex-0B). Then the statement "Vertical tab No. ?" is printed where the question mark represents the cumulative number of vertical tabs issued by the CPU.

**NOTE**

**ALL VERTICAL TABS SHOULD BE PRINTED ONE  
LINE BELOW THE DESIGNATED HORIZONTAL  
REFERENCE LINE FOR THE PAGE.**

### III.C.4.M

The End of Document Test starts testing by printing on line one number 4. It prints; "Line NO XX", where XX represents the line number. This is repeated over and over again until the last line is printed. After the last line is printed, the printer hardware issues a "Top-of-Form" command. The paper is suppose to advance to the top of a new page. The program then issues its own "Top-of-Form", a hex code (0C). Therefore, there should be a blank page for a successful end of document test.

There are four types of Carriage Return Tests. One to check for short lines, one to verify the right limit switch, the program software carriage return, and finally, the carriage-return overrun or a line that is longer than the print buffer.

The first test prints 85 characters then issues a hex code (0D). The result is five consecutive lines of data.

The second test issues the equivalent to five full lines of data, 660 characters. The right-hand limit switch detects the last printable character (at 132 characters) and issues a hardware line feed. Thus, breaking up the 660 characters into five lines of 132 characters.

The third carriage return test issues five lines of data, 132 printable characters and a hex(0D). Therefore, the right-hand limit switch is reached and the hardware issues a carriage return in addition to the software. The printer should ignore the second carriage return. If it does not ignore the second carriage return, then there will be a blank line between the lines or doubled spaced output.

#### 4) Print Consistency Group

This first test is designed to ensure that all the characters are printed accurately, have good print quality and consistency. All the characters must look good and have good legibility.

The second print consistency test checks and tries to issue the worse-case pin firing, hoping to find a solenoid that is not responding fast enough.

5) Special Feature Test Group

This is the section of the diagnostic where the sub-routine is written strictly for the given printer under test. In this section there are seven Special Feature Tests.

- 1 - Quarter Line feed up
- 2 - Quarter Line feed down
- 3 - Variable line spacing
- 4 - Highlighting and underscoring
- 5 - Expand 12
- 6 - 10 pitch vertical expandable character set
- 7 - 12 pitch vertical expandable character set

The Quarter Line Feed Up subtest demonstrates the fact that characters could be vertically offset to demonstrate hyphenations and subscripting.

The Quarter Line Feed Down demonstrates the same as the above, but in the other direction.

The Variable Line Spacing subtest demonstrates an overview of both of the above. It illustrates the fact that there can be 5 characters printed vertically where normally only 2 characters could be printed with the conventional printer.

The highlighting and underscore test demonstrates in greater detail the form of line-feed suppression demonstrated in all of the Special Function Tests described above. The high intensity of the words "HIGHLIGHTING" and expanded "PRINTER" demonstrates this feature. The printer is programmed not to advance the paper to enable the head assembly to make four separate passes on the same line. Thus, the words HIGHLIGHTING and PRINTER should be darker than the rest of print line.



### III.C.4.M

The Expanded 12 Pitch section is designed to verify that the printer will only expand one full line of data and not any less or any more than 66 expanded characters.

The Ten Pitch Vertical Expandable Character Set section causes the program to print out a two tenth's high expanded 96 character set in the ten pitch mode. This display will follow the same display as the standard character set.

The Twelve Pitch Vertical Expandable Character Set section causes the program to print out a two tenth's high expanded 96 character set in the 12 pitch mode. This display will follow the same constraints as that described for the standard character set.

#### 6) Operator Action Tests Group

This test requires the operator to verify or perform some sort of action. The operator will follow the instructions on the CRT. The program waits for the operator's OK to start testing.

There are three operator action tests in this diagnostic:

- 1) Select/Deselect and Audio with extra CPU line feeds
- 2) Operator Clear
- 3) Forms Override/Paper Empty switches

In the first test, the program displays all the instructions on the CRT screen and the program waits for the operator's instruction to continue testing. During this test, the operator is required to select and deselect the printer while it is in operation. The diagnostic is testing and verifying that the printer does not lose any characters or control during this period of selecting and deselecting the printer.

In the second test (Operator Clear Test), again the instructions are displayed on the CRT and the program waits for the operator to complete the instructions. This section verifies that the clear button on the control console is functioning properly.

In the third test (Forms Override/Paper Empty switches), again the instructions are displayed on the CRT and the program waits for the operator's command to continue testing. This section verifies that the PAPER OUT micro-switch is functioning and that the FORMS/- OVERRIDE switch on the control console is also operating properly.

#### 7.2.4 LOOPING DIAGNOSTICS FOR SCOPING

When any function is suspected as being faulty the diagnostic portion for that function should be used. For example, when a line-feed problem exists, the Line-Feed Tests 1 and 2 of the submenu should be used. This test constantly loops, providing a constant line feed. If any malfunction is observed, troubleshooting is greatly aided by simply scoping of the line feed circuit from the line-feed solenoid back to where the proper signal is observed to pinpoint the defective component.

## 7.3 PREVENTIVE MAINTENANCE

### 7.3.1 (QUARTERLY) LUBRICATION

Print Head lubrication is a requirement to reduce print wire breakage.

#### NOTE

LUBRICANT CAN BE ORDERED USING WANG PART NO. 660-0180.

Remove the print head cover. Remove the sponge from the print wires and soak it with the lubricant. Press the sponge against the rear of the print bearing. This forces some of the lubricant into the bearing holes. Replace sponge and print head cover.

Immediately after lubricating, exercise the print head for several minutes so that each solenoid is used. This allows the lubricant to make contact with all surfaces of the bearing.

## 7.4 TROUBLESHOOTING

### 7.4.1 TROUBLESHOOTING HINTS

TABLE 7-1

SYMPTOM	CAUSE	SOLUTION
1) Power turn on and no lights.	1A. Power fuse blown. 1B. +5V low. 1C. No voltage. 1D. Q1 (heat sink) bad. No +5V to logic.	1A. Replace power fuse. 1B. Check and adjust +5V. 1C. Replace 7379. 1D. Replace Q1.
2) Power turn on and alarm light	2A. Servo fuse open. 2B. Servo fuse blows repeatedly.	2A. Replace servo fuse. 2B. Adjust SW0 and SW1 as per Section 6.17 and 6.18.
3) Print is inverted.	3A. 7377 Fingerboard reversed. 3B. 7378 Fingerboard reversed.	3A. Reverse 7377. 3B. Reverse 7378.
4) Power prime and carriage does not return to left margin.	4A. Check servo fuse. 4B. Check for paper jam in paper guide preventing carriage from returning. 4C. Carriage drive belt and pulleys binding.	4A. Replace fuse. 4B. Remove paper. Check paper guides for alignment and tension. 4C. Check adjustments as per Section 6.11.
5) Power on; depress select button and select lamp does not come on.	5A. Defective lamp. 5B. Replace switch. 5C. Defective connection to switch. 5D. Defective 7332.	5A. Replace lamp. 5B. Defective switch. 5C. Continuity check. 5D. Replace 7332.

#### NOTE

USE THE SAME PROCEDURE FOR CHECKING TOP OF FORM, CLEAR AND LINEFEED SWITCHES.

(THESE SWITCHES ARE CONNECTED TO 7332 PC BOARD).

SYMPTOM	CAUSE	SOLUTION
6) Front cover is open; CPU tells printer to print but no carriage movement.	6A. Cover open switch is on. 6B. Cover open.	6A. Manually pull switch to closed position. 6B. Close cover.
7) Front cover is closed; CPU tells printer to print but no carriage movement.	7A. Cover open switch wired wrong. 7B. Cover open switch defective. 7C. Defective 7332.	7A. Check wiring. 7B. Replace switch. 7C. Replace 7332.
8) Erratic forward motion of carriage during printing.	8A. Defective servo circuit. 8B. Defective servo.	8A. Replace 7379 or 7332. 8B. Replace servo motor.
9) Carriage assembly returning at slow speed after printing a line.	9A. SW1 reed switch defective (shorted). 9B. 7332 PCB defective.	9A. Replace reed switch 9B. Replace 7332.
10) Carriage return fast with no deceleration.	10A. Defective 7332. 10B. SW1 appears defective. (Open)	10A. Replace 7332. 10B. Replace SW1 or align magnet.
11) No power to servo drive mechanism, but power lights on.	11A. Servo fuse open. 11B. Bad connection. 11C. +5V logic not up.	11A. Replace fuse. 11B. Check seating of pins and connectors. 11C. Adjust +5V logic.
12) No printing, but carriage movement.	12A. No WS signal. 12B. Defective magnetic pickup. 12C. Timing on 7332.	12A. Check magnetic pickup signal. 12B. Replace magnetic pickup. 12C. Adjust 50% duty cycle on 7332. or replace 7332.
13) No delays between manual line feeds.	13A. 7332 defective.	13A. Replace 7332.
14) No line feeds except under program control.	14A. Defective line feed switch. 14B. Defective 7332.	14A. Replace switch. 14B. Replace 7332.

SYMPTOM	CAUSE	SOLUTION	
15) Continuous paper feed when top of form executed.	15A. Defective 7332.	15A. Replace 7332.	
16) Poor print quality at one specific location.	16A. Burr or dirt on support rod.	16A. Check carriage bearing guide shaft or plate for dirt or burrs at that location.	
	16B. Defective timing disk.	16B. Replace timing disk.	
17) Poor print quality everywhere (characters not symmetrical).	17. . Timing 7332.	17A. Adjust 50% duty cycle 7332.	
	17B. Magnetic pickup.	17B. Replace magnetic pickup.	
	17C. Head penetration.	17C. Adjust head penetration.	
	17D. Solenoids in head maladjusted.	17D. Remove head assembly and adjust print head to specification.	
	17E. Print head loose.	17E. Tighten head.	
18) Missing dots in character	18A. Defective ROM on 7333.	18A. Replace ROM in 7333.	
	18B. Defective pwr. transistor on 7379.	18B. Replace transistor on 7379.	
	18C. Maladjusted solenoid.	18C. Adjust solenoid.	
	18D. Broken solenoid wire.	18D. Replace solenoid.	
19) Print head catching ribbon during printing.	19A. Head penetration exceeds .000".	19A. Adjust penetration.	
	19B. Ribbon worn out with too much head penetration.	19B. Replace ribbon and adjust penetration.	
	19C. Solenoid staying in fixed position.	19C1. Replace solenoid.	19C1. Replace solenoid.
		19C2. Replace pwr. transistor on 7379.	19C2. Replace pwr. transistor on 7379.
	19C3. Replace 7332.	19C3. Replace 7332.	
19D. Strobe too long.	19D. Adjust strobe length.		
20) Print quality light on one side.	20A. Striker bar maladjusted.	20A. Adjust striker bar.	

## SYMPTOM

21) Paper streaked during print.

22) No printing, but carriage moves to right and fails to return. Servo fuse blows.

## CAUSE

21A. Head penetration to close.

21B. Paper not within usable specs.

21C. Print solenoid dragging on paper.

21D. Ribbon cartridge guides maladjusted.

22A. Loss of WS strobe.

22B. Missing index pulse.

22C. Defective 7332 PCB.

## SOLUTION

21A. Increase head to striker bar gap.

21B. Advise user to replace with paper meeting specifications.

21C. Adjust solenoid.

21D. Adjust cartridge ribbon guides.

22A. Check adjustment of magnetic pickup A and wires.

22B. Check adjustment of magnetic pickup B and wires.

22C. Replace 7332 PCB.

## 7.5 115 VAC/230 VAC CONVERSION

To convert the Model 2231W-6 Printer to/from 115 Vac or 230 Vac, remove the cover from the ON/OFF switch and fuse assembly and switch the 115/230 Vac selector switch to the desired position. After changing the 115/230 Vac switch position, change fuse as follows:

1.5A (SB) for 115 Vac  
8/10A (SB) for 230 Vac

Replace switch and fuse cover assembly.

## 7.6 RECOMMENDED SPARE PARTS LIST

DESCRIPTION	PART NO.
Print Head	279-5060-88
Solenoid	279-5060-14
CPU	210-7332
Memory	210-7333
Regulator Driver	210-7379
Keyboard	210-6762
Reed Switch	325-2416
Servo Motor Fuse 2-1/2	360-1025SB
Main Fuse	360-1016SB
Magnetic Pickup	325-2417
Fan Assembly	279-0226
Carriage Motor Assy	279-5060-91
Carriage Motor and encoder bracket assy	279-5060-90

## 7.7 PRINTER CABLES

220-0105-1	Printer I/O cable
220-3003	14 Conductor 40" flat cable assembly (control panel)
270-3061	Reed switch harness
220-3051	Print head cable



# **CHAPTER**

## **8**

# **DISASSEMBLY PROCEDURES AND ILLUSTRATED PARTS LIST**

## CHAPTER 8

# DISASSEMBLY PROCEDURES AND ILLUSTRATED PARTS LIST

### 8.1 INTRODUCTION

The disassembly procedures contained in paragraph 8.2 are to be accomplished using the parts lists and exploded view drawings contained in paragraph 8.3. The parts lists are located on the 8-1/2" X 11" apron of each exploded view drawing. When the parts lists are too large for the apron alone they are contained on the page facing the exploded view drawing and its apron so that the part numbers can be readily identified with the exploded view drawing folded out. Also, this 8-1/2" X 11" apron allows viewing the exploded view drawings (folded out) while performing the disassembly procedures contained in paragraph 8.2.

### 8.2 DISASSEMBLY PROCEDURES

#### 8.2.1 COVER REMOVAL AND REPLACEMENT

##### NOTE

ALL FIGURE REFERENCES ARE TO FIGURE 8-1  
UNLESS OTHERWISE INDICATED

- 1) Lift front of cover upwards and release cover support latch (16).
- 2) Using both hands lift cover assembly upward slightly from its normal position and move cover assembly toward rear as it is lifted to release the cover assembly.
- 3) Perform disassembly of cover assembly to that extent required for repair as shown in Figure 8-1.

## 8.2.2 HEAD ADJUSTMENT ARM REMOVAL AND REPLACEMENT

### NOTE

ALL FIGURE REFERENCES ARE TO FIGURE 8-4.

- 1) Loosen socket head screw (9c) from hex nut (9e) and slide head adjustment arm assembly (9a) from L.H. pivot pin (6).
- 2) Perform disassembly of head adjustment arm assembly (9a) to the extent required for repair as shown in Figure 8-4.

## 8.2.3 HORIZONTAL VERNIER CLUTCH REMOVAL AND REPLACEMENT

### NOTE

ALL FIGURE REFERENCES ARE TO FIGURE 8-3

UNLESS OTHERWISE INDICATED

- 1) Remove socket head screw (15) and flat washer (6a) located in vernier knob (13) and slide knob from spline shaft (18).
- 2) Remove snap ring (22) and shaft spacer (14) from vernier actuating rod (21).
- 3) Remove two screws (6b) and lock washers (5f) from actuator pivot bracket (7b) and then remove vernier pivot arm assembly (7) from side frame (2).
- 4) Loosen four mounting screws (19) to release timing belt (14) tension. (See Figure 8-4).
- 5) Remove two hex nuts (12) and format control bracket assembly (11a) with flange bearing (11b) in place from motor bracket (20a). (See Figure 8-4).

- 6) Remove two retainer rings (13e), three shaft spacers (13d) and spring (13c) from vernier actuating rod (13b). (See Figure 8-4).
- 7) Remove snap ring (22) and slide vernier actuating rod (21) with two shaft spacers (19) and vernier clutch spring (20) in place from right to left out of the printer.
- 8) Remove snap ring (18) from idler gear pivot (17b) and slide idler spur gear (16) from idler gear bracket assembly (17a). (See Figure 8-4).
- 9) To reassemble, reverse the order of the above procedure.
- 10) Perform the paper movement gears checks and adjustments contained in paragraphs 6.3.22 and 6.3.23.

#### **8.2.4 PAPER FEED SPROCKETS AND PAPER GUIDE COVER REMOVAL AND REPLACEMENT**

##### **NOTE**

**ALL FIGURE REFERENCES ARE TO FIGURE 8-3  
UNLESS OTHERWISE INDICATED.**

- 1) Remove socket head screw (15) and flat washer (6a) located in vernier knob (13) and slide knob from spline shaft (18).
- 2) Remove snap ring (22) and shaft spacer (14) from vernier actuating rod (21).
- 3) Remove two screws (6b) and lock washer (5f) from actuator pivot bracket (7b) and then remove vernier pivot arm assembly (7) from side frame (2).
- 4) Loosen four mounting screws (19) to release timing belt (14) tension. (See Figure 8-4).

### III.C.4.M

- 5) Remove two hex nuts (12) and format control bracket assembly (11a) with flange bearing (11b) in place from motor bracket (20a). (See Figure 8-4).
- 6) Remove two retainer rings (13e), three shaft spacers (13d) and spring (13c) from vernier actuating rod (13b). (See Figure 8-4).
- 7) Remove snap ring (22) and slide vernier actuating rod (21) with two shaft spacers (19) and vernier clutch spring (20) in place from right to left out of the printer.
- 8) Remove snap ring (18) from idler gear pivot (17b) and slide idler spur gear (16) from idler gear bracket assembly (17a). (See Figure 8-4).
- 9) Remove roll pin (7a) and then vernier actuating arm (7c).
- 10) Remove paper drive spur gear (10) and shaft spacer (13d) from left end of spline shaft (24). (See Figure 8-4).
- 11) Remove Phillips screw (22, Figure 8-4) from left end and flat hd. screw (23a) from right end of guide rod (23).
- 12) Loosen both paper margin knobs (10, Figure 8-7) and lift paper guide cover assemblies (3, Figure 8-7) in place on guide rod (23) from printer. (See Figure 8-2).

#### CAUTION

WHEN REMOVING AND REPLACING THE MOLDED DRIVE SPROCKET (13, FIGURE 8-7) FOR ANY REASON, ENSURE THAT BOTH LEFT AND RIGHT SPROCKET TEETH LINE UP ON THE SPLINED SHAFT. EACH SPROCKET HAS A MOLDED RIB ON ITS INSIDE HUB WHICH IS KEYED FOR PROPER ALIGNMENT AND PROPER PAPER DRIVE.

- 13) To reassemble the paper-feed-sprocket assembly, reverse the order of the above procedure.
- 14) Perform the checks and adjustments contained in paragraphs 6.3.18 and 6.3.19

## 8.2.5 LOWER PAPER GUIDE ASSEMBLY REMOVAL AND REPLACEMENT

### NOTE

ALL FIGURE REFERENCES ARE TO FIGURE 8-8  
UNLESS OTHERWISE INDICATED.

- 1) Set the head adjustment arm (9a, Figure 8-4) to position L.
- 2) Remove the four Philip-head screws (2) lockwashers (9) and the striker plate (1) from the lower paper guide assembly.
- 3) Disconnect the two wires from the paper out switch (17c) by pulling them from the switch terminals.
- 4) Remove the two print head mounting screws (9, Figure 8-5) and lift the print head assembly (15) from the carriage assembly (16). (See Figure 8-2.)
- 5) Remove the four bottom feed paper guide screws (11), lockwashers (9), flatwashers (3) and the bottom feed paper guide (17a).
- 6) Remove the three pem nuts (16d), paper tension clamp (16c) and paper tension spring (16b).
- 7) To reassemble the paper guide assembly, reverse the order of the above procedure.
- 8) Perform the paper guide checks and adjustments contained in paragraphs 6.3.1 and 6.3.2.

## 8.2.6 STRIKER PLATE REMOVAL AND REPLACEMENT

### NOTE

ALL FIGURE REFERENCES ARE TO FIGURE 8-8  
UNLESS OTHERWISE INDICATED.

- 1) Set the head adjustment arm (9a, Figure 8-4) to position L.
- 2) Remove the four screws (2), lockwashers (9) and the striker plate (1) from the lower paper guide assembly.
- 3) To reassemble the striker plate reverse the order of the above procedure.
- 4) Perform striker plate adjustment contained in paragraph 6.3.6.

## 8.2.7 CARRIAGE SERVOMOTOR REMOVAL AND REPLACEMENT

### NOTE

ALL FIGURE REFERENCES ARE TO FIGURE 8-4  
UNLESS OTHERWISE INDICATED.

- 1) Using two 7/16" wrenches, loosen nut (2a) on idler pulley stud (2d) to release tension on carriage drive timing belt (12, Figure 8-2) and disconnect belt from idler pulley (2i).
- 2) Remove three hex-head screws (1) holding carriage drive servo motor (5a) to right side frame (2). (See Figure 8-3.)
- 3) Unplug servo magnetic pick up cable fingerboard (6g) from connector 7065 on chassis (18, Figure 8-9). (See Figure 8-3.)

- 4) Perform disassembly of the carriage drive servo motor (5a) with attaching parts to the extent required for repair as shown in Figure 8-3.
- 5) Reverse order of the above procedure to reassemble the carriage servo motor.
- 6) Perform carriage drive servo motor checks and adjustments contained in paragraphs 6.3.7 and 6.3.8.

## 8.2.8 CARRIAGE ASSEMBLY REMOVAL AND REPLACEMENT

- 1) Remove ribbon cartridge as follows:
  1. Position head adjustment arm (9a, Figure 8-4) to load (L).
  2. Release ribbon cartridge spring (7, Figure 8-6) and pull out and up on right side of ribbon cartridge until it is free from its spindle.
  3. Remove the ribbon from the print head ribbon guide (8a, Figure 8-5) and then remove the ribbon cartridge.
- 2) Remove the head adjustment arm as follows:

### NOTE

#### ALL FIGURE REFERENCES ARE TO FIGURE 8-4

1. Loosen socket head screw (9c) from hex nut (9e) and slide head adjustment arm assembly (9a) from L.H. pivot pin (6).
2. Perform disassembly of head adjustment arm assembly (9a) to the extent required for repair as shown in Figure 8-4.



## III.C.4.M

- 3) Remove the carriage drive timing belt as follows:
  1. Using two 7/16" wrenches, loosen nut (2a, Figure 8-4) on idler pulley stud (2d, Figure 8-4) to release tension on carriage drive belt (12, Figure 8-2).
  2. Disconnect timing belt (12, Figure 8-2) from idler pulley (2i, Figure 8-4).
- 4) Slide bumper (28) on each end of carriage shaft (26) toward center of shaft, loosen Allen head set screws (27) and slide L.H. and R.H. pivot pins (6) from shaft. (See Figure 8-4.)
- 5) Remove carriage drive timing belt (12, Figure 8-2) from carriage servo drive motor pulley (5b, Figure 8-3).
- 6) Remove the two bumpers (28) from carriage shaft (26) and slide carriage assembly (16, Figure 8-2) off of carriage shaft (26). (See Figure 8-4.)
- 7) Reverse order of above procedure to reassemble.
- 8) Readjust carriage drive timing belt tension as described in paragraph 6.3.8.
- 9) Readjust head adjustment arm as described in paragraph 6.3.4.

### 8.2.9 CARRIAGE DRIVE TIMING BELT REMOVAL AND REPLACEMENT

- 1) Remove ribbon cartridge as follows:
  1. Position head adjustment arm (9a, Figure 8-4) to load (L).

2. Release ribbon cartridge spring (7, Figure 8-6) and pull out and up on right side of ribbon cartridge until it is free from its spindle.
  3. Remove the ribbon from the print head ribbon guide (8a, Figure 8-5) and then remove the ribbon cartridge.
- 2) Remove the head adjustment arm as follows:

**NOTE**

**ALL FIGURE REFERENCES ARE TO FIGURE 8-4.**

1. Loosen socket head screw (9c) from hex nut (9e) and slide head adjustment arm assembly (9a) from L.H. pivot pin (6).
  2. Perform disassembly of head adjustment arm assembly (9a) to the extent required for repair as shown in Figure 8-4.
- 3) Remove the carriage drive timing belt as follows:
1. Using two 7/16" wrenches, loosen nut (2a, Figure 8-4) on idler pulley stud (2d, Figure 8-4) to release tension on carriage drive timing belt (12, Figure 8-2).
  2. Disconnect timing belt (12, Figure 8-2) from idler pulley (2i, Figure 8-4).
  3. Slide bumper (28) on each end of carriage shaft (26) toward center of shaft, loosen Allen head set screws (27) and slide L.H. and R.H. pivot pins (6) from shaft. (See Figure 8-4.)
  4. Remove carriage drive timing belt (12, Figure 8-2) from carriage servo drive motor pulley (5b, Figure 8-3.)

### III.C.4.M

5. Remove the two bumpers (28) from carriage shaft (26) and slide carriage assembly (16, Figure 8-2) off of carriage shaft (26). (See Figure 8-4.)
  6. Turn carriage assembly (16, Figure 8-2) upside down, remove two screws (3), lockwashers (21) and belt top clamp (14) from belt bottom clamp (15) to release carriage drive timing belt (13). (See Figure 8-6.)
- 4) To reassemble, reverse the order of the above procedure.
  - 5) Readjust carriage drive timing belt tension as described in paragraph 6.3.8.
  - 6) Readjust head adjustment arm as described in paragraph 6.3.4.

## 8.2.10 SOLENOID AND PRINT WIRE REMOVAL AND REPLACEMENT

### NOTE

IF MORE THAN ONE SOLENOID AND/OR WIRE REQUIRE REPLACEMENT; ONLY ONE SOLENOID SHOULD BE REMOVED, REPLACED AND ADJUSTED AT ONE TIME.

ALL FIGURE REFERENCES ARE TO FIGURE 8-5 UNLESS OTHERWISE INDICATED.

- 1) Remove print head (15, Figure 8-2) from carriage assembly (16, Figure 8-2) by removing the two screws (9) holding the print-head to the carriage assembly.
- 2) Loosen two screws (1) and remove print-head cover (2) from print head.
- 3) Loosen 7378 fingerboard retainer bracket and remove 7378 fingerboard.
- 4) Identify, tag and unsolder wires from 7378 fingerboard.
- 5) Loosen desired nylon tip (7a), lock-set screw (3) or locknut (6) and unscrew solenoid (7b) from head casting (8).
- 6) Remove lubricant pad (5) and any broken wire material at pad location.
- 7) Using the 31W End Cap Remover (WL #726-9709) remove the end cap (7a) to replace wire as follows: (See Figure 8-5.)

### III.C.4.M

1. Position tool on end cap making sure the two ears have a firm grip on plastic end cap as shown below:

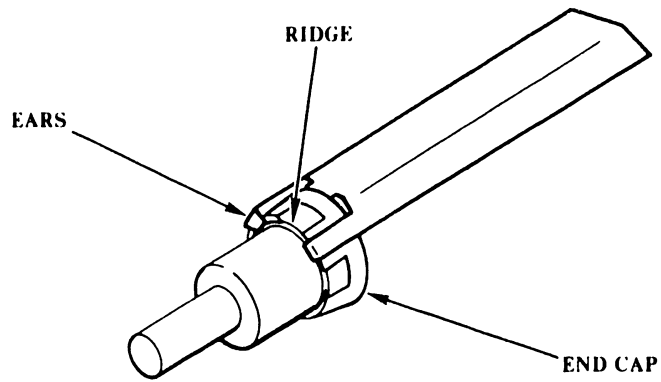

2. Exert a downward force on end of tool until end cap has positioned itself over ridge on solenoid body as shown below. Remove tool.

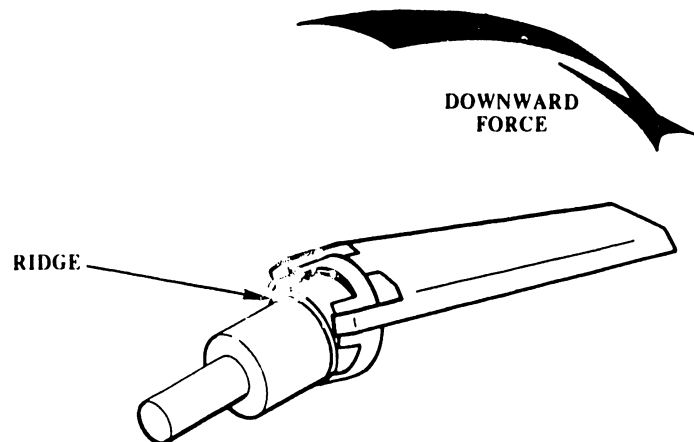

3. Position on opposite side of solenoid body as illustrated below. Exert an upward force on tool causing end cap to slide over ridge on solenoid body.
4. At this point grasp end cap with fingers and pull away from solenoid body.

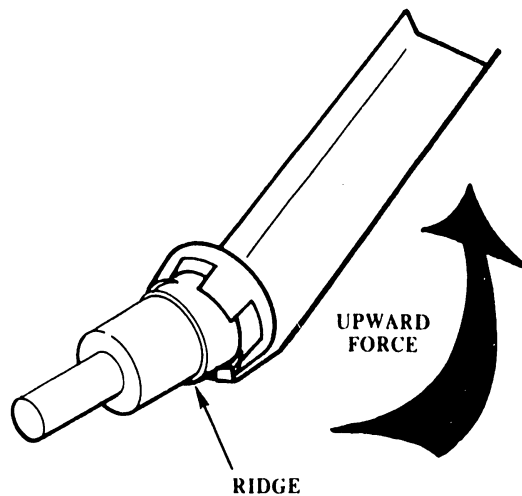

- 8) Remove print wire from solenoid.
- 9) Replace new print wire in the solenoid using a pair of tweezers (or springhook) to guide the wire into its guide tube and then into its respective bearing hole.

#### NOTE

SEPARATING THE TWO ROWS OF PRINT WIRES WITH  
A FEELER GAUGE AIDS IN GUIDING THE NEW  
SOLENOID WIRE INTO THE PRINT-HEAD BEARING.

- 10) Solder solenoid wires to 7378 fingerboard. (Wang Logo faces front of printer.)

**CAUTION**

**THE NEXT STEP IS LUBRICATING THE  
NEW SOLENOID WIRE AND THE BEARING.  
LUBRICATION IS NECESSARY OR DAMAGE  
TO THE NEW WIRE WILL RESULT.**

- 11) Dip the lubrication pad (5) into the lubricant material obtained from Home Office (WL #660-0180). No other lubricant may be substituted. Place pad back into the print head housing. Tip the head forward to allow the lubricant to reach the tip of the print wires.
- 12) Perform the adjustment checks and adjustments contained in paragraphs 6.3.9 and 6.3.10.
- 13) Replace print head (15, Figure 8-2) on carriage assembly (16, Figure 8-2 with two screws (9)) and operate for several minutes to ensure that lubricant is distributed (lubricant has a wax base and does not flow readily).
- 14) Adjust for print quality.
- 15) Replace print-head cover (2) and tighten 7378 fingerboard retainer bracket.

**8.2.11 REED SWITCHES AND MOUNTING BRACKET  
REMOVAL AND REPLACEMENT**

**NOTE**

**ALL FIGURE REFERENCES ARE TO FIGURE 8-4 UNLESS  
OTHERWISE INDICATED. REMOVAL AND REPLACEMENT  
OF THE REMAINING TWO REED SWITCHES IS IDENTICAL  
TO THE PROCEDURE CONTAINED BELOW.**

Reed Switch

- 1) Remove the two screws (29a) securing reed switch (29b), reed switch insulator (29c), and reed switch nut plate (29e) to reed switch bracket (29d). (For location see Figure 8-2.)

**CAUTION**

**WHEN SOLDERING OR UNSOLDERING REED SWITCH (29b) DO NOT OVERHEAT SOLDER LUGS AS THIS WILL DAMAGE THE SWITCH.**

- 2) Identify, tag and unsolder the wire from reed switch (29b).

Reed Switch Bracket

- 1) Remove fingerboard 7063 from its connector on chassis (19, Figure 8-9).
- 2) Remove the two hex head screws (4) lockwashers (5), nut plate (30) securing reed switch bracket (29d) to the L.H. side frame (1, Figure 8-4).

**NOTE**

**REMOVAL OF RIGHT END OF REED SWITCH BRACKET  
(29d) FROM R.H. SIDE FRAME (2, FIGURE 8-3)  
IS THE SAME AS STEP 2) ABOVE.**

- 3) Lift reed switch bracket (29d) from printer.
- 4) To reassemble, reverse the order of the above procedure.
- 5) After repair and reassembly, perform the Reed Switches and Mounting Bracket adjustment check and adjustments contained in paragraphs 6.3.13 and 6.3.14.

**8.2.12 REED SWITCH MAGNET REMOVAL AND REPLACEMENT**

- 1) Remove ribbon cartridge as follows:



### III.C.4.M

1. Position head adjustment arm (9a, Figure 8-4) to load (L).
  2. Release ribbon cartridge spring (7, Figure 8-6) and pull out and up on right side of ribbon cartridge until it is free from its spindle.
  3. Remove the ribbon from the print head ribbon guide (8a, Figure 8-5) and then remove the ribbon cartridge.
- 2) Remove the head adjustment arm as follows:

#### NOTE

#### ALL FIGURE REFERENCES ARE TO FIGURE 8-4

1. Loosen socket head screw (9c) from hex nut (9e) and slide head adjustment arm assembly (9a) from L.H. pivot pin (6).
  2. Perform disassembly of head adjustment arm assembly (9a) to the extent required for repair as shown in Figure 8-4.
- 3) Remove the carriage drive timing belt as follows:
1. Using two 7/16" wrenches, loosen nut (2a, Figure 8-4) on idler pulley stud (2d, Figure 8-4) to release tension on carriage drive belt (12, Figure 8-2).
  2. Disconnect timing belt (12, Figure 8-2) from idler pulley (2i, Figure 8-4).
- 4) Slide bumper (28) on each end of carriage shaft (26) toward center of shaft, loosen Allen head set screws (27) and slide L.H. and R.H. pivot pins (6) from shaft. (See Figure 8-4.)
- 5) Remove carriage drive timing belt (12, Figure 8-2) from carriage servo drive motor pulley (5b, Figure 8-3).

- 6) Remove the two bumpers (28) from carriage shaft (26) and slide carriage assembly (16, Figure 8-2) off of carriage shaft (26). (See Figure 8-4.)
- 7) Remove screw (25e) securing magnet (25d) to bearing housing (25c) and remove magnet. (See Figure 8-6.)

#### NOTE

WHEN REPLACING THE MAGNET IT MUST BE POSITIONED SO THAT IT PASSES OVER THE REED SWITCHES WITH THE SLOT PARALLEL TO THE DIRECTION OF CARRIAGE MOTION AS VIEW FROM EITHER THE LEFT OR RIGHT SIDE OF THE PRINTER.

- 8) Reverse order of above procedure to reassemble.
- 9) Readjust carriage drive timing belt tension as described in paragraph 6.3.8.
- 10) Readjust head adjustment arm as described in paragraph 6.3.4.
- 11) After repair and replacement perform the Reed Switch Magnet Adjustment check contained in paragraph 6.3.15.

### 8.2.13 MAGNETIC PICKUPS REMOVAL AND REPLACEMENT

#### NOTE

ALL FIGURE REFERENCES ARE TO FIGURE 8-3

- 1) Identify, tag and unsolder magnetic pickup (6g) wires.
- 2) Loosen pickup locking nuts (6f) and unscrew magnetic pickups (6g).

### III.C.4.M

- 3) Reverse order of above procedure to reassemble.
- 4) After replacement perform the Magnetic Reluctance Pickup and Timing Disk adjustment check and adjustment procedures contained in paragraphs 6.3.16 and 6.3.17.

#### 8.2.14 RIBBON DRIVE ASSEMBLY AND CARTRIDGE GUIDES REMOVAL AND REPLACEMENT

##### NOTE

ALL FIGURE REFERENCES ARE TO FIGURE 8-6  
UNLESS OTHERWISE NOTED.

- 1) Remove ribbon cartridge as follows:
  1. Position head adjustment arm (9a, Figure 8-4) to load (L).
  2. Release ribbon cartridge spring (7) and pull out and up on right side of ribbon cartridge until it is free from its spindle.
  3. Remove the ribbon from the print head ribbon guide (8a, Figure 8-5) and then remove the ribbon cartridge.
- 2) Remove print head (15, Figure 8-2) from carriage assembly (16, Figure 8-2) by removing fingerboard 7378 from connector and removing the two screws (9, Figure 8-5) holding the print head to the carriage assembly.
- 3) Remove the socket head screw (8) securing each cartridge guide (12) to the carriage plate assembly.
- 4) Compress cable tension spring (12, Figure 8-3) on right side frame (2, Figure 8-3) and slide cable (31, Figure 8-4) upward out of spring.

- 5) Remove cable (31, Figure 8-4) from wire pulley (23) and slide cable from L.H. side frame (1, Figure 8-4).
- 6) Remove snap ring from bottom of ribbon drive housing assembly (22), two screws (4) from top of ribbon drive housing assembly (22) and remove it from the carriage plate assembly (1).
- 7) Remove two socket head screws (8), flat washers (5), spring spacer (10) and cartridge spring (7) from carriage plate assembly (1).
- 8) For reassembly, reverse the order of the above procedure.
- 9) Perform the Head Adjustment Arm check and adjustment procedures contained in paragraphs 6.3.3 and 6.3.4.
- 10) Perform the Ribbon Clutch Assembly and Cartridge Guides checks and adjustments contained in paragraphs 6.3.11 and 6.3.12.

### 8.3 ILLUSTRATED PARTS LIST

This paragraph contains the parts lists and each associated exploded view drawing. The parts lists are located on the 8-1/2" X 11" apron of the exploded view drawing (when too large for the apron alone they start on the facing page and finish on the apron). This allows the user to view the folded out exploded view drawing while performing removal and replacement procedures and identifying part numbers. Each part list contains the exploded view drawing title, figure number and assembly number when applicable. The following is a list of the exploded view drawings:

FIGURE	TITLE	PAGE NO.
8-1	COVER ASSEMBLY	8-21/8-22
8-2	SHAFT ASSEMBLY LOCATIONS	8-23
8-3	RIGHT HAND SIDE FRAME ASSEMBLY	8-25
8-4	LEFT HAND SIDE FRAME ASSEMBLY	8-27/8-28
8-5	PRINT HEAD ASSEMBLY	8-29
8-6	CARRIAGE ASSEMBLY	8-31/8-32
8-7	PAPER GUIDE COVER ASSEMBLY	8-33/8-34
8-8	LOWER PAPER GUIDE ASSEMBLY	8-35
8-9	CHASSIS ASSEMBLY	8-37/8-38

## 8.3.1 COVER ASSEMBLY PARTS LIST (SEE FIGURE 8-1)

(279-4018)

ITEM NO.	PART NO.	DESCRIPTION
- 1	451-2131-5	Front cover
- 2	449-0128	R.H. side cover
- 3	449-0127	L.H. side cover
- 4	461-3261	Aligning rod
- 5	461-3246	Pivot rod
- 6	446-0027	Cover window
- 7	452-2556	Window stiffener
- 8	650-2121	4-40 x 3/8 screw
- 9	450-0904	Wang name tag
-10	458-0346-5	L.H. dress cap
-11	458-0347-5	R.H. dress cap
-12	461-3264	Ball stud
-13	660-0554	Side cover screen
-14	652-0029	8-32 Locknut
-15	462-0279	Step spacer
-16	458-0356	Cover support latch
-17	654-1233	Grommet 5/16 ID X 7/16 OD
-18	462-0278	Spacer
-19	653-4000	#8 Washer
-20	650-4240	8-32 X 3/4 Screw

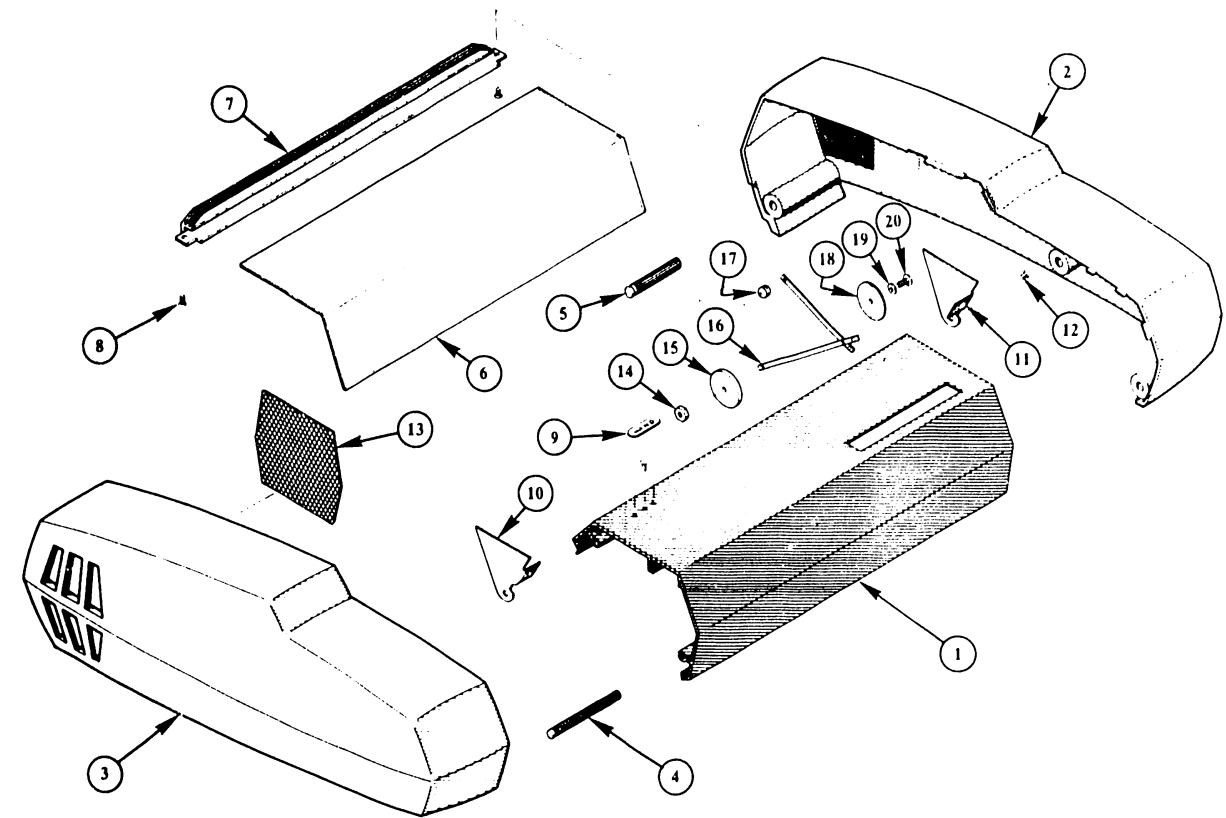

FIGURE 8-1 COVER ASSEMBLY

8.3.2 SHAFT ASSEMBLIES PARTS LIST (SEE FIGURE 8-2)  
(NO ASSEMBLY NO.)

ITEM NO.	PART NO.	DESCRIPTION
- 1	461-3235	Vernier actuating rod
- 2	461-3234	Guide rod
- 3	651-1719	Snap ring
- 4	462-0259	Shaft spacer
- 5	465-1632	Vernier clutch spring
- 6	461-1029	Paper support disk
- 7	461-3240	Spline shaft
- 8	465-1628	Disk separator spring
- 9	452-0040	Striker plate
-10	461-3233	Roller shaft
-11	461-3239	Carriage shaft
-12	656-0225	Timing belt
-13	279-5060-46	Reed switch Assy.
-14	279-5060-27	Wire rope assembly
-15	279-5060-88	Print Head Assy.
-16	279-5060-86	Carriage Assy.

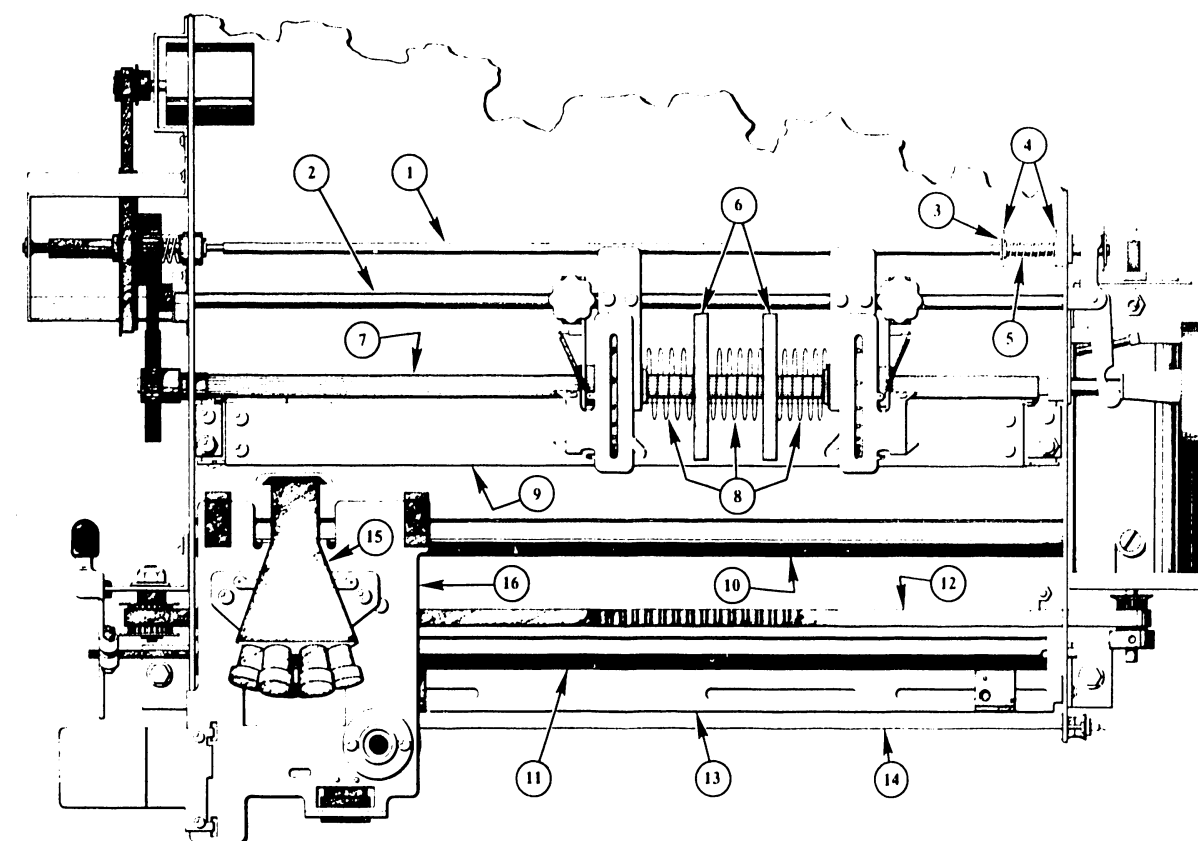

FIGURE 8-2 SHAFT ASSEMBLY LOCATIONS

**8.3.3 RIGHT HAND SIDE FRAME ASSEMBLY PARTS LIST (SEE FIGURE 8-3)  
(NO ASSEMBLY NO.)**

ITEM NO.	PART NO.	DESCRIPTION
- 1	650-4133	8-32 x 3/8 screw
- 2	452-0043	Side frame
- 3	279-0226	Fan assembly
- 3a	400-9005	Wire fan guard
- 3b	400-0020	Fan motor
- 3c	650-4160	8-32 X 1/2 Screw
- 4	653-3000	#6 flat washer
- 5	279-5060-90	Carriage motor & encoder brkt
- 5a	400-0032	Carriage drive motor
- 5b	449-0210	Pulley
- 5c	461-2027	Encoder pickup gear (12P)
- 5d	650-4016	8-32 X 3/16 Soc. Hd. set screw
- 5e	650-4120	8-32 x 3/8 screw
- 5f	653-4001	#8 lock washer
- 5g	654-1286	Cable clamp
- 5h	651-1516	Roll Pin
- 6	279-5060-26	Encoder bracket assembly
- 6a	653-4000	#8 flat washer
- 6b	650-4080	8-32 x 1/4 screw
- 6c	651-1516	Roll pin
- 6d	452-0042	Adjusting plate
- 6e	451-4405	Encoder bracket
- 6f	652-0053	Locking nut
- 6g	325-2417	Magnetic pickup
- 7	279-5060-17	Vernier pivot arm assy.
- 7a	651-1521	Roll pin
- 7b	451-4401	Actuator pivot bracket
- 7c	458-0333	Vernier actuating arm
- 7d	465-0721	Bushing



- 8	451-4407	Hold down bracket
- 9	650-9013	1/4-20 x 1/2 screw
-10	279-5060-27	Wire Rope Assy
-10a	465-0417	Cable collar
-10b	465-0728	Cable bushing
-10c	458-0275	Carrier Cable End Fitting
-11	652-3000	6-32 Hex nut
-12	465-1631	Cable tension spring
-13	449-0137	Vernier knob
-14	462-0258	Shaft spacer
-15	650-4240	8-32 x 3/4 socket head screw
-16	451-4448	Latch Support Bracket
-17	461-3234	Guide Rod
-18	461-3240	Spline Shaft
-19	462-0259	Shaft Spacer
-20	465-1632	Vernier Clutch Spring
-21	461-3235	Vernier Actuating Rod
-22	651-1719	Snap Ring
-23	461-3233	Roller Shaft
-23a	650-6161	10-32 X 3/8 Flat Head CTSK Screw
-24	655-0236	5/16" Bumper
-25	461-3248	Right Hand Pivot Pin
-26	461-3289	Carriage Shaft
-27	279-5060-46	Reed Switch Assy.
-27a	650-2125	4-40 X 3/8 Socket Head Screw
-27b	325-2416	Reed Switch
-27c	615-0364	Reed Switch Insulator
-27d	451-4403	Reed Switch Bracket
-27e	461-0104	Reed Switch Nut Plate
-28	650-4320	8-32 X 1 Socket Head Screw

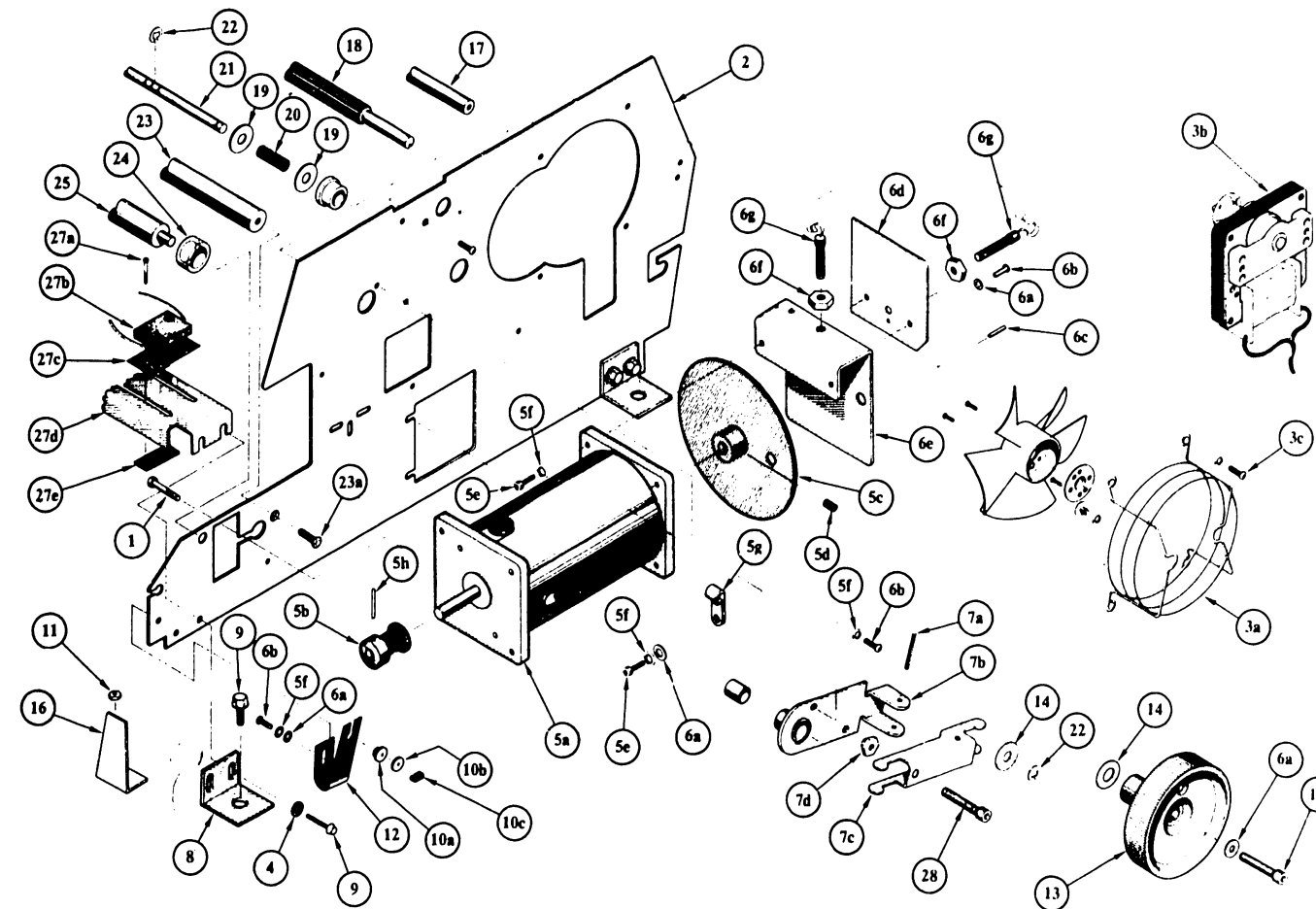

FIGURE 8-3 RIGHT HAND SIDE FRAME ASSEMBLY

III.C.4.M

8.3.4 LEFT HAND SIDE FRAME ASSEMBLY PARTS LIST (SEE FIGURE 8-4)  
(NO ASSEMBLY NO.)

ITEM NO.	PART NO.	DESCRIPTION
- 1a	452-0043	L.H. Side frame
- 1b	465-0721	Bushing
- 2	279-5060-33	Idler Pulley Assy
- 2a	652-0064	1/4-28 Nut
- 2b	653-6006	1/4 Flat Washer
- 2c	451-4402	Idler Pulley Bracket
- 2d	461-3238	Idler Pulley Stud.
- 2e	465-1627	Head Adj. Detent spring
- 2f	650-4080	8-32 X 1/4 Screw
- 2g	653-0040	#4 Flat Washer
- 2h	465-0248	Needle bearing
- 2i	449-0123	Carriage drive idler pulley
- 2j	651-1732	Snap ring
- 3	451-4407	Hold down bracket
- 4	650-4133	8-32 X 3/8 screw
- 5	653-4001	#8 Lock Washer
- 6	461-3247	L.H. Pivot pin
- 7	651-1749	Snap ring
- 8	653-0016	Nylon Washer
- 9	279-5060-52	Head Adj. Arm assembly
- 9a	458-0334	Head Adj. Arm assembly
- 9b	550-0067	Adjustment
- 9c	650-4242	8-32 X 3/4 socket Head Screw
- 9d	653-4000	#8 Flat washer
- 9e	652-0029	8-32 Hex nut
-10	449-0126	Paper drive spur gear
-11	279-5060-9	Format control bracket assembly
-11a	451-4706	Format control bracket assembly
-11b	465-0252	Flange bearing
-12	652-4000	8-32 hex nut
-13	279-5060-32	Vernier shaft assy.
-13a	449-0133	Pulley

-13b	461-3235	Vernier actuating rod
-13c	465-1632	Vernier clutch spring
-13d	462-0258	Shaft spacer
-13e	651-1747	Retainer ring
-13f	461-3241	Format control shaft
-14	656-0226	Timing belt 62T
-15	656-5060-37	Paper feed motor assy.
-15a	279-5060-97	Paper feed motor wired
-15b	449-0124	Paper drive pulley
-15c	651-1533	Roll pin 0.093d X 0.75
-16	449-0125	Idler spur gear
-17	279-5060-28	Idler gear bracket assy.
-17a	451-4406	Idler gear bracket assy.
-17b	461-3242	Idler gear pivot
-18	651-1719	Snap ring
-19	650-4120	8-32 X 3/8 screw
-20	279-5060-45	Bracket and bushing assembly
-20a	451-4404	Motor bracket
-20b	465-0721	Bushing
-21	325-2303-M1	Cover open switch
-21a	650-2200	4-40 X 3/8 Screw
-21b	652-2000	4-40 Nut
-21c	653-2001	#4 Lock Washer
-21d	653-2000	#4 Flat Washer
-22	650-6120	10-32 X 3/8 screw
-23	461-3234	Guide Rod
-24	461-3240	Spline shaft
-25	461-3233	Roller shaft
-26	461-3239	Carriage shaft
-27	650-4061	8-32 X 3/16 socket head set screw
-28	655-0236	8/16 Bumper
-29	279-5060-46	Reed switch assembly
-29a	650-2125	4-40 X 3/8 socket head screw
-29b	325-2416	Reed Switch
-29c	615-0364	Reed Switch insulator
-29d	451-4403	Reed Switch bracket
-29e	461-0104	Reed Switch nut plate
-30	461-0102	Nut Plate
-31	279-5060-27	Wire rope assembly

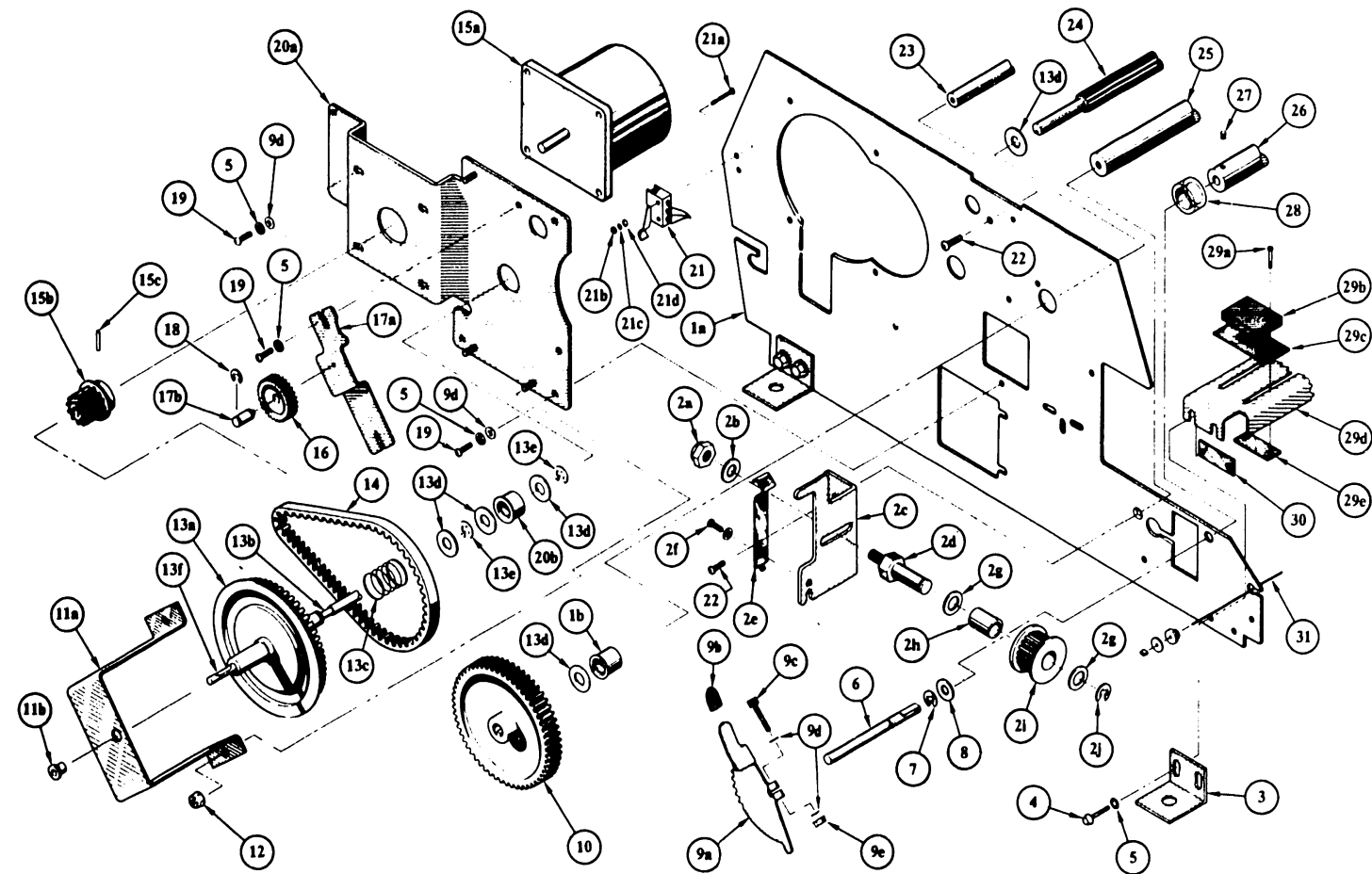

FIGURE 8-4 LEFT HAND SIDE FRAME ASSEMBLY

8.3.5 PRINT HEAD ASSEMBLY PARTS LIST (SEE FIGURE 8-5)  
(PART NO. 279-5060-88)

ITEM NO.	PART NO.	DESCRIPTION
- 1	650-2098	4-40 x 1/4 screw
- 2	449-0150	Print head cover
- 3	650-4086	8-32 x 15/64 set screw
- 4	650-0064	00-90 x 3/16 screw
- 5	660-0560	Wick
- 6	478-0406	Lock Nut
- 7	279-5060-14	Solenoid assy.
- 7a	449-0129	End Cap
- 7b	478-0517	Solenoid Body
- 7c	279-5060-31	Print Wire Assy
- 8	279-5060-89	Head and guide tube assembly
- 8a	449-0131	Ribbon guide
- 8b	465-0267	Print head bearing

Related Parts not part of above assembly.

- 9	650-6120	10-32 X 3/8 Screw
-10	650-2087	4-40 X 1/2 Panhead Screw
-11	425-3525	Head Shield

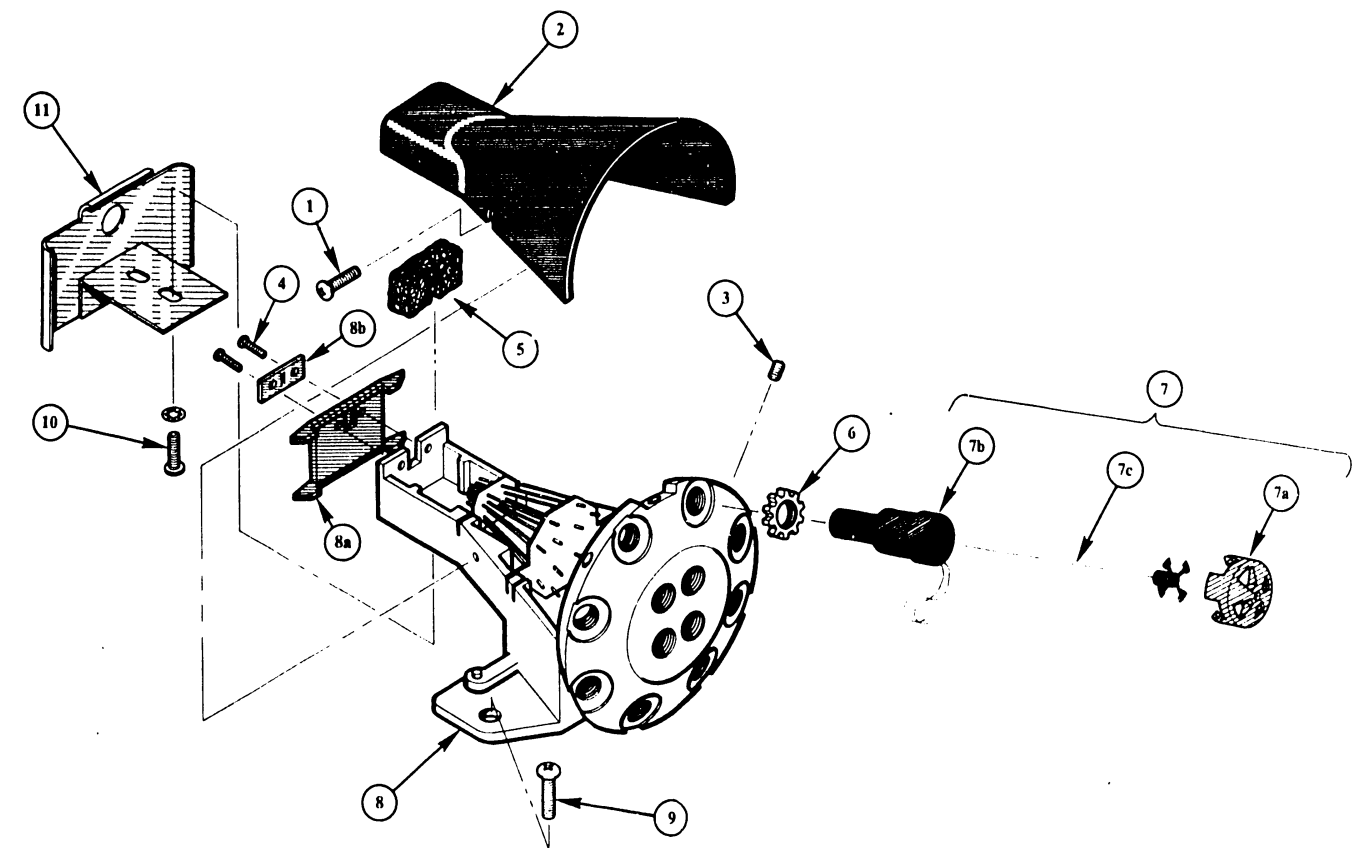

FIGURE 8-5 PRINT HEAD ASSEMBLY

8.3.6 CARRIAGE ASSEMBLY PARTS LIST (SEE FIGURE 8-6)

(279-5060-86)

ITEM NO.	PART NO.	DESCRIPTION
- 1	279-5060-87	Carriage plate assembly
- 2	451-4400	Flex cable bracket
- 3	650-3080	6-32 x 1/4 screw
- 4	650-3100	6-32 x 5/16 screw
- 5	653-3000	#6 flat washer
- 6	458-0332	Head PC board retainer
- 7	465-1626	Cartridge spring
- 8	650-3134	6-32 x 3/8 socket head screw
- 9	449-0136	Carriage roller
-10	462-0257	Spring spacer
-11	650-3081	6-32 x 1/4 screw
-12	449-0134	Cartridge guide
-13	656-0225	Timing belt
-14	452-2554	Belt top clamp
-15	452-2555	Belt bottom clamp
-16	651-1712	Snap ring
-17	461-3236	Eccentric pin
-18	651-1724	Retaining ring
-19	465-1629	Spring
-20	465-0729	Eccentric pin bushing
-21	653-3001	#6 Lockwasher
-22	279-5060-24	Ribbon drive housing assy.
-23	279-5060-25	Wire pulley assy.
-24	651-1719	Snap Ring

Related Components not part of above assemblies.

-25	279-5060-50	Bearing Housing & Felt Assy.
-25a	449-0138	Retainer
-25b	656-0105	Felt Ring
-25c	461-3270	Bearing Housing
-25d	656-1006	Magnet
-25e	650-1160	Screw
-26	220-3051	Head Cable
-27	279-5060-27	Wire Rope Assy.

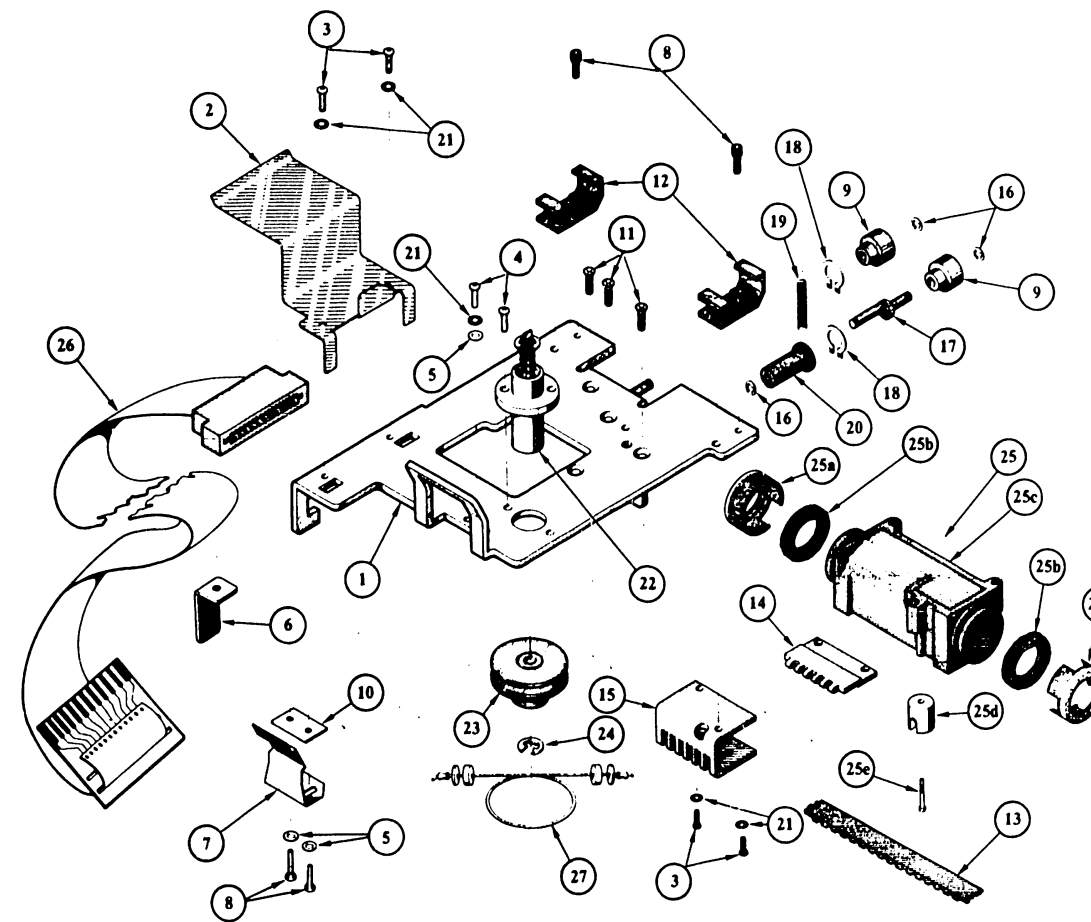

FIGURE 8-6 CARRIAGE ASSEMBLY

## 8.3.7 PAPER GUIDE COVER ASSEMBLY PARTS LIST (SEE FIGURE 8-7)

(279-5070-38 L.H.)

(279-5070-39 R.H.)

ITEM NO.	PART NO.	DESCRIPTION
- 1	465-1614	Spring
- 2	650-3124	6-32 x 3/8 screw
- 3	451-2104	Paper guide cover
- 4	461-3199	Sprocket cover pivot
- 5	650-2098	4-40 x 1/4 screw
- 6	458-0305	R.H. paper lift arm
	458-0304	L.H. paper lift arm
- 7	650-2241	4-40 x 3/4 screw
- 8	465-0730	Sprocket bushing
- 9	650-2062	4 - 40 X 3/16 screw
-10	655-0167	Paper margin knob
-11	279-5070-41	R.H. paper feed side plate assy.
	279-5070-40	L.H. paper feed side plate assy.
-11a	461-3198	Spring pin

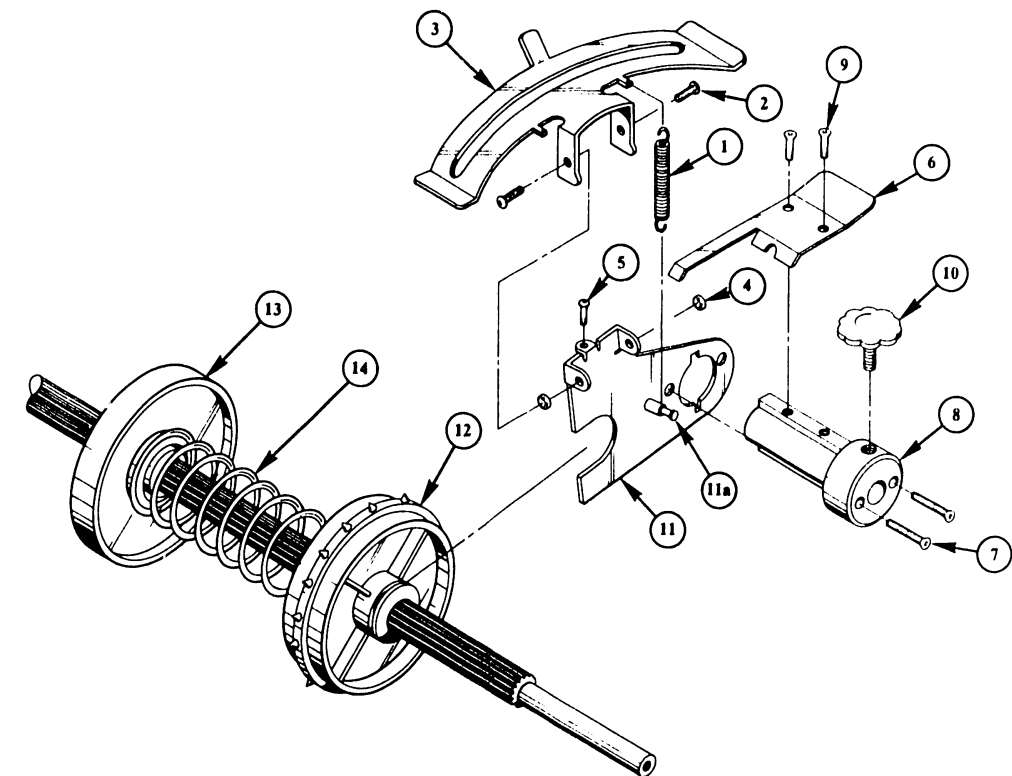

FIGURE 8-7 PAPER GUIDE COVER ASSEMBLY

Related components not part of this assembly.

-12	478-0332	L.H. Sprocket Assy.
	478-0333	R.H. Sprocket Assy.
-13	461-1029	Paper Support Disk
-14	465-1628	Disk Separator Spring

8.3.8 LOWER PAPER GUIDE ASSEMBLY PARTS LIST (SEE FIGURE 8-8)  
(NO ASSEMBLY NO.)

ITEM NO.	PART NO.	DESCRIPTION
- 1	452-0040	Striker plate
- 2	650-4200	8-32 x 5/8 screw
- 3	653-4000	#8 flat washer
- 4	451-4467	L.H. plate mounting bracket
- 5	451-4468	R.H. plate mounting bracket
- 6	451-4469	L.H. Platen Adj. Bracket
- 7	451-4470	R.H. Platen Adj. Bracket
- 8	652-0019	8-32 Flangenut
- 9	653-4001	#8 lock washer
-10	650-4160	8-32 x 1/2 screw
-11	650-4080	8-32 x 1/4 screw
-12	652-3000	6-32 nut
-13	653-3001	#6 lock washer
-14	653-3000	#6 flat washer
-15	451-3353	Eccentric Platen Adj.
-16	279-5060-54	Paper tension brkt & spring assy
-16a	451-4412	Paper tension bracket
-16b	465-1634	Paper tension spring
-16c	452-2557	Paper tension clamp
-16d	652-0025	4-40 Pem nut
-17	279-5060-35	Paper Pan and switch assembly
-17a	452-4035	Bottom feed paper guide
-17b	461-0103	Nut plate
-17c	325-2403M1	Paper out switch
-17d	653-2000	#4 flat washer
-17e	650-2200	4-40 x 5/8 screw

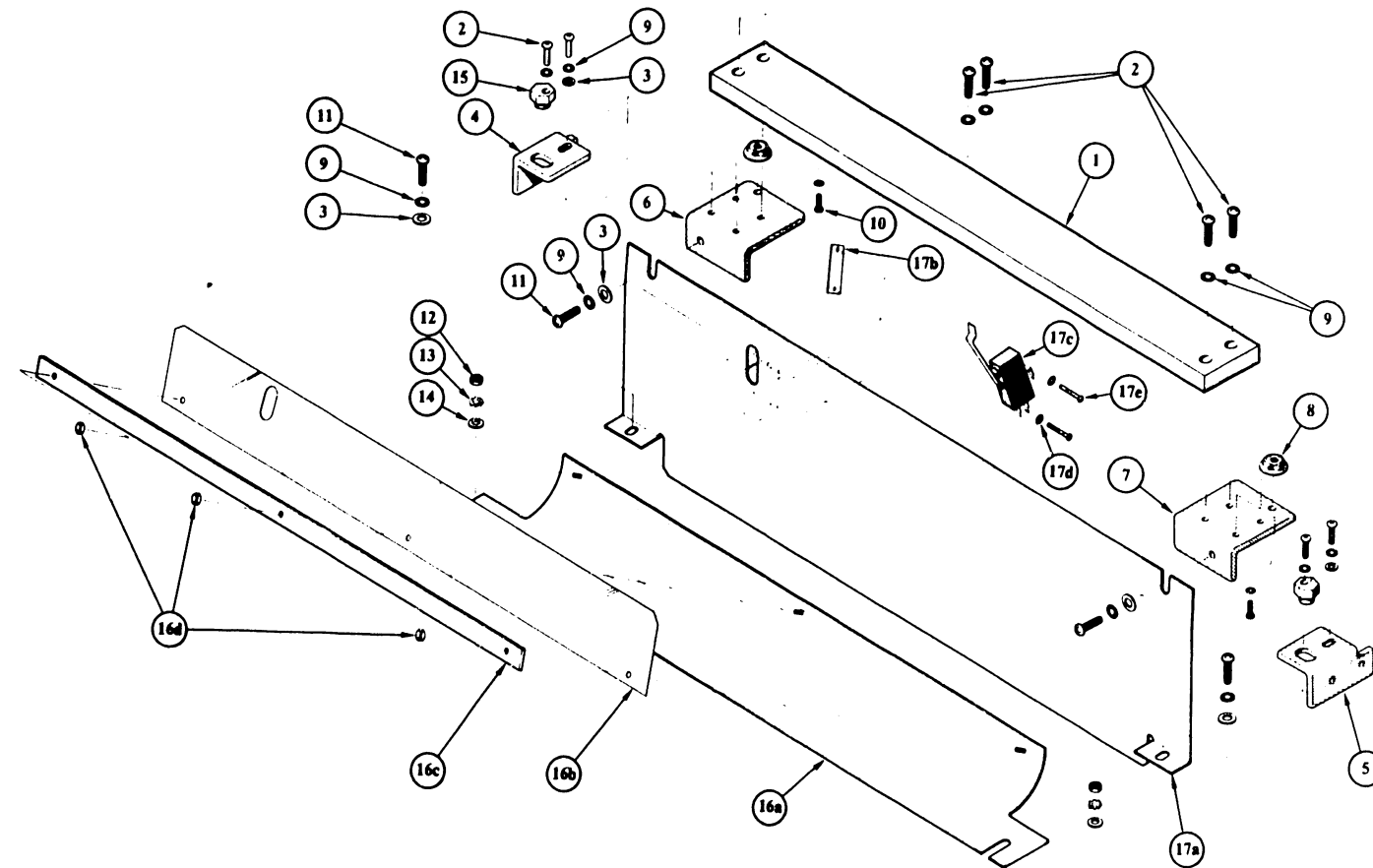

FIGURE 8-8 LOWER PAPER GUIDE ASSEMBLY

**8.3.9 CHASSIS ASSEMBLY PARTS LIST (SEE FIGURE 8-9)**  
**(270-0555)**

ITEM NO.	PART NO.	DESCRIPTION
- 1	320-0300	Speaker, 3" rect. (FILMOR TS-27)
- 2	650-3120	SEMS, 6-32 x 3/8 PAN HD PHL
- 3	653-3001	Washer #6 INT.T Lock
- 4	410-2006	Line Filter 3S1 3 amp
- 5	380-5001	250V Varistor V250 LA 20
- 6	653-2000	Washer, #4 flat
- 7	653-2002	Washer, #4 INT T Lock
- 8	652-2005	4-40 KEPS nut
- 9	410-0102	Transformer
-10	650-6120	Screw, #10-32 x 3/8 PAN HD PHL
-11	653-6001	Washer, #10 INT. T. lock
-12	653-6000	Washer, #10 flat
-13	300-9009	Clamp, 1 1/4" dia 2 lub cap (CMC-22)
-14	210-7062	Paper Feed Motor Fingerboard
-15	210-7063	Reed Switch Harness Fingerboard
-16	300-3074	Capacitor 7.3 UF, 40V
-17	300-3076	Capacitor 12K UF, 25V
-18	210-7065	Carriage Motor Fingerboard
-19	451-1096	Chassis, silk screened
-20	654-1290	Snap bushing SB-1.00-12
-21	325-2112	Switch, 115/230 VAC slide
-22	300-3075	Capacitor 14K, UF, 12V
-23	350-1051	Connector 25 Position Submin. Skt.
-24	350-1044	Connector 18-36 PC Edge Mount
-25	350-1045	Connector 25-50 PC Edge Mount
-26	210-7331	Motherboard
-27	210-7333	PCB 12 Solenoid Memory Board



- 28      210-7332      PCB 12 Solenoid CPU
- 29      210-7379      PCB 12 Solenoid PS Reg.
- 30      452-3536      Shield, AC
- 31      360-9002      Nut, hex fuse
- 32      451-4721      Brkt., fuse mtg.
- 33      650-3092      Screw, 6-32 x 1/4 FLAT HD PHL  
100 degrees CTSK
  
- 34      654-1238      Grommet, (HEYCO SP-4)
- 35      420-1096      Cord, 3 cond. power
- 36      325-0021      ON-OFF rocker switch (SPDT)
- 37      360-0001      Holder, straight contact fuse
- 38      360-1016SB    1-1/2 Amp fuse SLO BLO 250V
- 39      360-1025SB    2-1/2 Amp SLO BLO fuse 250V
- 40      654-0074      AC receptacle

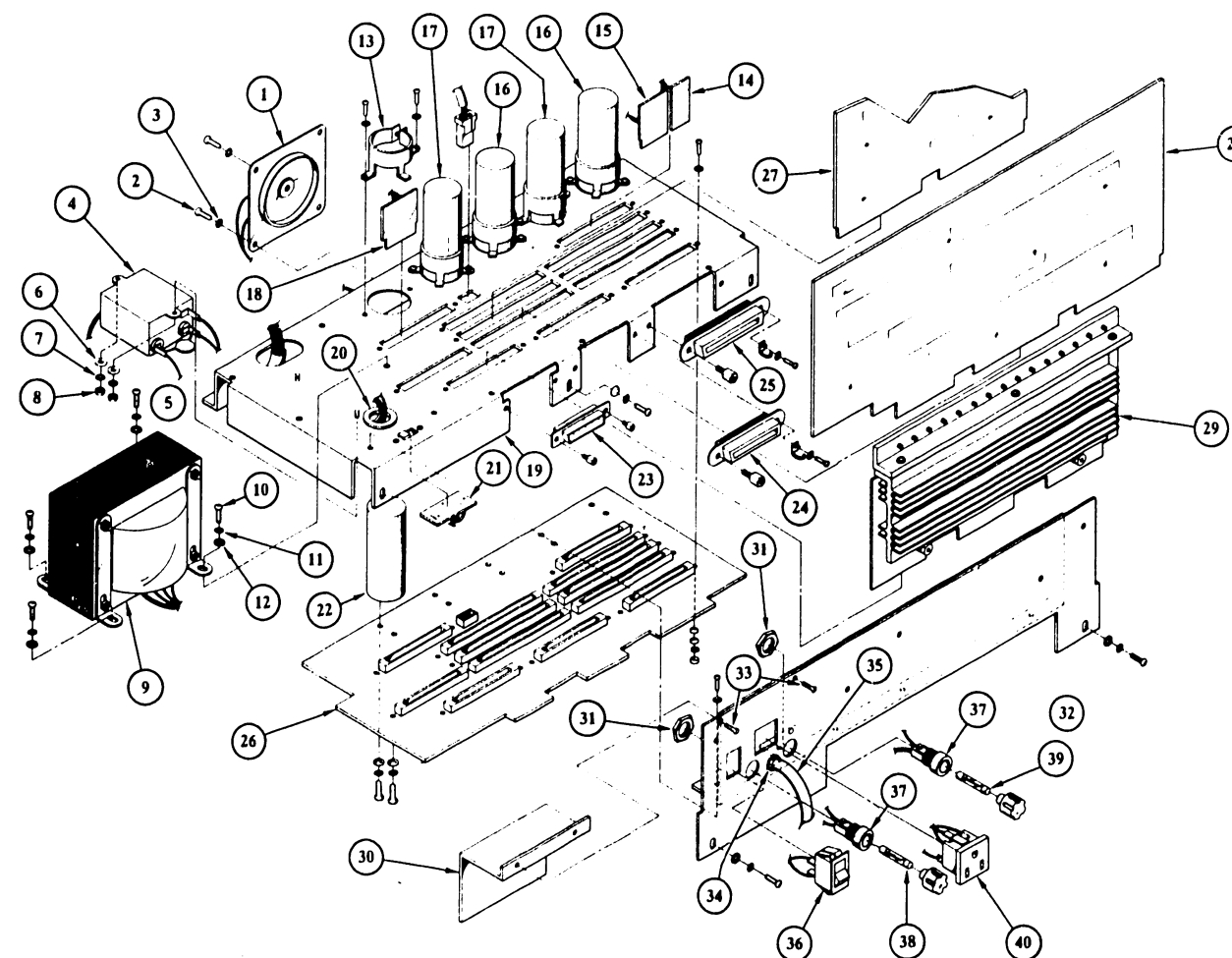

FIGURE 8-9 CHASSIS ASSEMBLY

**CHAPTER**

**9**

**APPEN-**

**DICIES**

**CHAPTER 9  
APPENDICES**

	<u>PAGE</u>
<b>A PAPER SPECIFICATIONS</b>	<b>A-1</b>
<b>B HEXADECIMAL CODES</b>	<b>B-1</b>
<b>C HEXADECIMAL CODES FOR UNDERSCORED CHARACTERS</b>	<b>C-1</b>
<b>D SIGNAL MNEMONICS</b>	<b>D-1</b>

## APPENDIX A

### PAPER SPECIFICATIONS

(If paper does not conform to these specifications, degraded forms handling can occur.)

- 1) Material must be margin-perforated, fanfold paper or card stock; perforations are used for guiding by pin-feed units.
- 2) Form length is variable to a maximum of three pages, HEX (02090318) = 792-1/24" increments, after which the printer automatically returns to this value.
- 3) Paper Stock:
  - a) For single part forms, use 15 to 20 lb bond (20 lb for improved forms handling).
  - b) For multipart forms use:
    - 2 ply: 15/15 lb bond, 7 lb carbon
    - 3 ply: 15/12/15 lb bond, 7 lb carbon
    - 4 ply: 12/12/12/15 lb bond, 7 lb carbon
    - 5 ply: 12/12/12/12/15 lb bond, 5 lb carbon(up to four copies in addition to the original can be used)
  - c) Form width must be:
    - 3 1/2 inches (8.9 cm) minimum.
    - 13 1/2 inches (34.3 cm) maximum (edge-to-edge).
- 4) Fastening of multipart forms:
  - a) Improved multipart paper handling can be achieved with glued margins.

### III.C.4.M

- b) Multipart form must otherwise be fastened with crimps every two inches (5.1 cm) along both edges of the forms. NCR or other specialty paper can be fastened up to four parts of the form length.
  - c) Crimp must not come closer to the fanfold than 0.50 inch (1.27 cm).
  - d) Each crimp must have four prongs, two to enter both form and carbon and two to enter forms only. Card stock should be tested first.
- 5) Forms thickness:
- a) Maximum in the print area: 0.018 inch (0.046 cm) (allows for four 12-lb, one 15-lb and four 7-lb carbon parts).
  - b) Over crimps in the pin-feed margin: 0.030 inch (0.076 cm).
- 6) Sprocket holes:
- a) Must run along both margins  $0.25 \pm 0.03$  inch ( $0.635 \pm 0.076$  cm) from paper edge to the hole center lines.
  - b) Distance between hole centers along the margins must be  $0.5 \pm 0.005$  inch ( $1.27 \pm 0.013$  cm) non-accumulative in any 5 inch (12.7 cm) length.
  - c) Hole diameters must be  $0.156 \pm 0.005$  inch ( $0.396 \pm 0.03$  cm). The two top and bottom drive holes on each sheet (four per sheet) can be up to 0.200 inch (0.508 cm) in diameter to permit post or ring binding of output.
  - d) Distance between hole centers across the sheet must be uniform within 0.015 inch (0.038 cm) to a maximum of 12-5/16 inch (31.27 cm).

- 7) When using forms with wide and narrow copies in the same set, the top copy should always be the fullest width.
- 8) For pre-printed forms:
  - a) Pin-hole center to left side of left-most character cannot be less than  $3/8 \pm 1/16$  inch ( $1.0 \pm 0.2$  cm).
  - b) Pin-hole center to right side of last character cannot be less than  $3/8 \pm 1/16$  inch ( $1.0 \pm 0.2$  cm).

## APPENDIX B

### HEXADECIMAL CODES

HEX CODE	PRINTER CHARACTER OR OPERATION	HEX CODE	PRINTER CHARACTER	HEX CODE	PRINTER CHARACTER
HEX(020000)	Suppress Line Feed	HEX(30)	0	HEX(58)	X
HEX(020001)	Quarter Line Feed	HEX(31)	1	HEX(59)	Y
HEX(020002)	Half Line Feed	HEX(32)	2	HEX(5A)	Z
HEX(020003)	Three Quarter Line Feed	HEX(33)	3	HEX(5B)	[
HEX(020004)	Normal Line Feed	HEX(34)	4	HEX(5C)	\
HEX(0200XX)	Variable Line Feed	HEX(35)	5	HEX(5D)	]
HEX(0201)	Set 10-pitch	HEX(36)	6	HEX(5E)	↑
HEX(0202)	Set 12-pitch	HEX(37)	7	HEX(5F)	~
HEX(0209**)	Form Length	HEX(38)	8	HEX(60)	^
HEX(020A**)	Printed Lines Per Form	HEX(39)	9	HEX(61)	a
HEX(07)	Line Feed	HEX(3A)	:	HEX(62)	b
HEX(0A)	Line Feed	HEX(3B)	;	HEX(63)	c
HEX(0B)	Vertical Tab	HEX(3C)	<	HEX(64)	d
HEX(0C)	Form Feed	HEX(3D)	=	HEX(65)	e
HEX(0D)	Carriage Return	HEX(3E)	>	HEX(66)	f
HEX(0E)	Expanded Character	HEX(3F)	?	HEX(67)	g
HEX(20)	Space	HEX(40)	@	HEX(68)	h
HEX(21)	!	HEX(41)	A	HEX(69)	i
HEX(22)	"	HEX(42)	B	HEX(6A)	j
HEX(23)	#	HEX(43)	C	HEX(6B)	k
HEX(24)	\$	HEX(44)	D	HEX(6C)	l
HEX(25)	%	HEX(45)	E	HEX(6D)	m
HEX(26)	&	HEX(46)	F	HEX(6E)	n
HEX(27)	'	HEX(47)	G	HEX(6F)	o
HEX(28)	(	HEX(48)	H	HEX(70)	p
HEX(29)	)	HEX(49)	I	HEX(71)	q
HEX(2A)	*	HEX(4A)	J	HEX(72)	r
HEX(2B)	+	HEX(4B)	K	HEX(73)	s
HEX(2C)	,	HEX(4C)	L	HEX(74)	t
HEX(2D)	-	HEX(4D)	M	HEX(75)	u
HEX(2E)	.	HEX(4E)	N	HEX(76)	v
HEX(2F)	/	HEX(4F)	O	HEX(77)	w
		HEX(50)	P	HEX(78)	x
		HEX(51)	Q	HEX(79)	y
		HEX(52)	R	HEX(7A)	z
		HEX(53)	S	HEX(7B)	{
		HEX(54)	T	HEX(7C)	
		HEX(55)	U	HEX(7D)	}
		HEX(56)	V	HEX(7E)	~
		HEX(57)	W	HEX(7F)	Clear Buffer

\*\* = XXXX

## APPENDIX C

## HEXADECIMAL CODES FOR UNDERSCORED CHARACTERS

HEX CODE	UNDERSCORED CHARACTER	HEX CODE	UNDERSCORED CHARACTER	HEX CODE	UNDERSCORED CHARACTER
HEX(A0)	Space	HEX(C0)	@	HEX(E0)	`
HEX(A1)	!	HEX(C1)	A	HEX(E1)	a
HEX(A2)	"	HEX(C2)	B	HEX(E2)	b
HEX(A3)	#	HEX(C3)	C	HEX(E3)	c
HEX(A4)	\$	HEX(C4)	D	HEX(E4)	d
HEX(A5)	%	HEX(C5)	E	HEX(E5)	e
HEX(A6)	&	HEX(C6)	F	HEX(E6)	f
HEX(A7)	'	HEX(C7)	G	HEX(E7)	g
HEX(A8)	(	HEX(C8)	H	HEX(E8)	h
HEX(A9)	)	HEX(C9)	I	HEX(E9)	i
HEX(AA)	*	HEX(CA)	J	HEX(EA)	j
HEX(AB)	+	HEX(CB)	K	HEX(EB)	k
HEX(AC)	,	HEX(CC)	L	HEX(EC)	l
HEX(AD)	-	HEX(CD)	M	HEX(ED)	m
HEX(AE)	.	HEX(CE)	N	HEX(EE)	n
HEX(AF)	/	HEX(CF)	O	HEX(EF)	o
HEX(B0)	0	HEX(D0)	P	HEX(F0)	p
HEX(B1)	1	HEX(D1)	Q	HEX(F1)	q
HEX(B2)	2	HEX(D2)	R	HEX(F2)	r
HEX(B3)	3	HEX(D3)	S	HEX(F3)	s
HEX(B4)	4	HEX(D4)	T	HEX(F4)	t
HEX(B5)	5	HEX(D5)	U	HEX(F5)	u
HEX(B6)	6	HEX(D6)	V	HEX(F6)	v
HEX(B7)	7	HEX(D7)	W	HEX(F7)	w
HEX(B8)	8	HEX(D8)	X	HEX(F8)	x
HEX(B9)	9	HEX(D9)	Y	HEX(F9)	y
HEX(BA)	:	HEX(DA)	Z	HEX(FA)	z
HEX(BB)	;	HEX(DB)	[	HEX(FB)	{
HEX(BC)	<	HEX(DC)	\	HEX(FC)	
HEX(BD)	=	HEX(DD)	]	HEX(FD)	}
HEX(BE)	>	HEX(DE)	↑	HEX(FE)	~
HEX(BF)	?	HEX(DF)	-		



## APPENDIX D SIGNAL MNEMONICS

SIGNAL	DEFINITION
A <sub>0</sub> - A <sub>15</sub>	Address bits of ROMS & RAMS
A STB	Port A Strobe
A RDY	Register A Ready
ACK	Acknowledge
ACKLG	Acknowledge at I/O Interface
AL	Alarm (output to speaker)
B <sub>0</sub> - B <sub>7</sub>	Port B Bus
B STB	Port B Strobe
B RDY	Register B Ready
B/A Sel	Port B or A Select
BUS REQ	Bus Request
BUSAK	Bus Acknowledge
BUSY	Device busy status for I/O
C/D	Control or Data is to be Written or Read
C/D Sel	Control or Data Select
CE	Chip Enable
CL	System clock
CLEAR	Manual clear switch
CLK	Clock Pulse (TTL)
CLK/TRG 0	Channel 0 External Clock or Timer Trigger
CO	Cover Open switch
CS	Chip Select/enable
CTC SEL	Select Counter/Timing Circuit chip
DOO-DO7	Data Output
D1a - D9a	9-Bit output of character generator ROMS (odd)
DEB RFSH	Debug Refresh
DIO - DI7	Data Input
DSTB	Data strobe at I/O interface
DT1-DT7	Data from 2200 mainframe
EVEN SOL EN	Even Solenoid Enable
FAULT	Fault status at I/O interface
FFM	Form feed manual switch
FIRE HO	Fire Odd Solenoids
FIRE HE	Fire Even Solenoids
FOR	Form override switch
FWD-L	FWD Carriage (low true)
IEI	Interrupt Enable IN
IEO	Interrupt Enable OUT
IN1-L to IN7-L	Input Port Strobe Signals
INDEX	Output of Index Pulse Transducer
INDEX HOLE	Hole on wheel used to detect 1st printable column
INT-L	Int Request (Low true)
IORQ	Input/Output Request
LATCHEN	Latch Enable, enables tri-state latches
LFM	Line feed manual switch
M	Output of servo motor driver
M <sub>0</sub>	Output of servo motor amplifier
M1	Machine Cycle One Signal from Z80

### III.C.4.M

MPA <sub>1</sub>	Magnetic pickup (tooth)
MPA <sub>2</sub>	Magnetic pickup common (tooth)
MPB <sub>1</sub>	Magnetic pickup (hole)
MPB <sub>2</sub>	Magnetic pickup common (hole)
MREQ	Memory Request
NMI	Non Maskable Interrupt
NORM/FAST	Norm, Fast Speed
ODD SOL EN	Odd Solenoid enable
OUT1-L to OUT7-L	Output control signal 1 thru 7
PDO-PD7	Processor data bus bits 0 - 7
PREST-L	Reset Pulse generated either by power ON or Out 0
PO	Paperout status at I/O interface
RD	Read Data Command
RESET	Input prom at I/O interface
RESET (Z80)	Reset pin on Z80 microprocessor
REV-L	Reverse Carriage Motor (low true)
RFSH	Mem refresh signal for dynamic RAMs
RM1, RM2	RAM memory 1, RAM memory 2
SEL	Select
SEL CH1, CH2, CH3, CH4	Select Channel 1, 2, 3, 4
SEL PG2	Select Program 2
SL	Select status
SPEED SW	Speed switch
SW0	Home position switch
SW1	Deacceleration switch
SW2	Return switch
TOOTH SENSOR	Magnetic Tooth Sensor/Senses column in vertical format
WAIT	Wait
WR	Write Data or Control Command
X	Output to motor winding (X)
X <sub>b</sub>	Common for motor winding (X)
X <sub>o</sub>	Output to stepping motor amplifier (X)
Y	Output to motor winding (Y)
Y <sub>b</sub>	Common for motor winding (Y)
Y <sub>o</sub>	Output to stepping motor amplifier (Y)
ZC/TO 0	Channel 0 Zero Count or Timeout

**CHAPTER**

**5**

**SCHE-**

**MATICS**

## CHAPTER 5 SCHEMATICS

PRINT	TITLE	PAGE
7331	12 SOLENOID HEAD, MOTHERBOARD	5-3/5-4, 5-5/5-6
7332	12 SOLENOID HEAD, CPU BOARD	5-7/5-8, 5-9/5-10, 5-11/5-12, 5-13/5-14
7333	12 SOLENOID HEAD, MEMORY BOARD	5-15/5-16, 5-17/5-18, 5-19/5-20
7379	12 SOLENOID HEAD, POWER SUPPLY REGULATOR	5-21/5-22, 5-23/5-24
6762	CONTROL PANEL KEYBOARD, SCHEMATIC	5-25

It should be noted that schematic 7333 sheet 2 of 3 (page 5-17/5-18) shows telecommunication circuits (TC) along with power ON circuits. Although the schematic indicates availability of TC, the printed circuits are not loaded.

Schematics have an apron so that when folded out they can be viewed as the theory in Chapter 4 is read. Where applicable, test points and adjustments are located physically and described electrically on the aprons.



ALL DIMENSIONS AND PART IDENTIFICATIONS ARE THE PROPERTY OF WANG LABORATORIES, INC. THIS DRAWING IS THE PROPERTY OF WANG LABORATORIES, INC. IT IS NOT TO BE REPRODUCED OR TRANSMITTED IN ANY FORM OR BY ANY MEANS, ELECTRONIC OR MECHANICAL, INCLUDING PHOTOCOPYING, RECORDING, OR BY ANY INFORMATION STORAGE AND RETRIEVAL SYSTEM, WITHOUT THE WRITTEN CONSENT OF WANG LABORATORIES, INC. NO PART OF THIS DRAWING IS TO BE REPRODUCED OR TRANSMITTED IN ANY FORM OR BY ANY MEANS, ELECTRONIC OR MECHANICAL, INCLUDING PHOTOCOPYING, RECORDING, OR BY ANY INFORMATION STORAGE AND RETRIEVAL SYSTEM, WITHOUT THE WRITTEN CONSENT OF WANG LABORATORIES, INC.

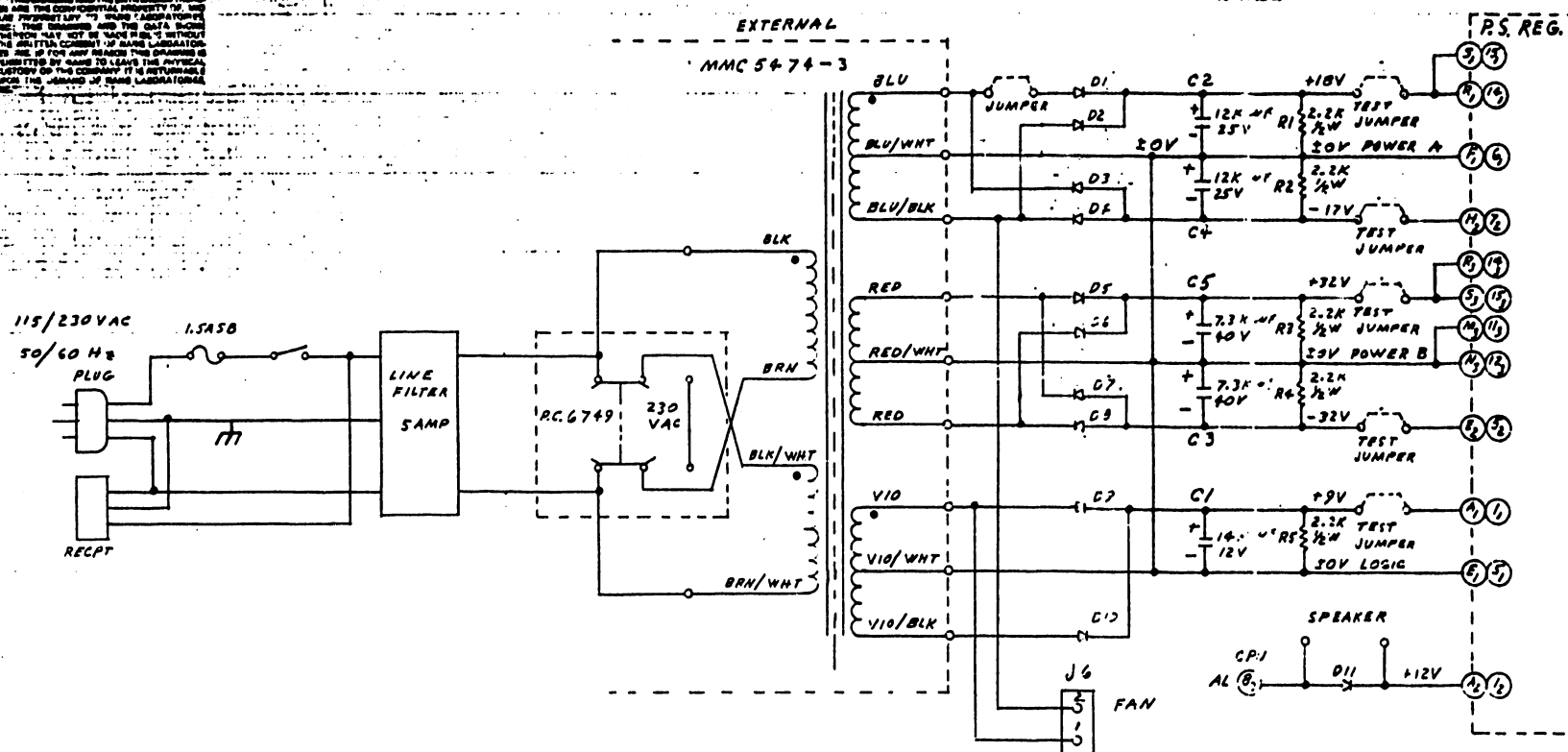

COMPONENT	W. L. PART NO.	TYPE
R1-5	331-3022	2.2K 1/2W 5%
RC	332-2027	270-1W 10%
RT	330-1047	47.2K 1/2W 10%
C1	300-3075	14.4µ 50V
C2, 4	300-3076	12Kµ 25V
C3, 5	300-3077	7.5µ 40V
D1-10	380-3332	1N4711
D11	380-3333	1N4754
CONN.	350-0011	30 POS
CONN.	350-0039	4 POS
CONN.	350-0021	4 POS
J1, 2	352-0511	30 POS
J3	352-2097	30 POS
J4	352-1044	36 POS
J6	352-1135	2 POS

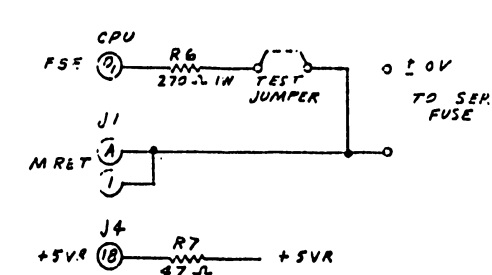
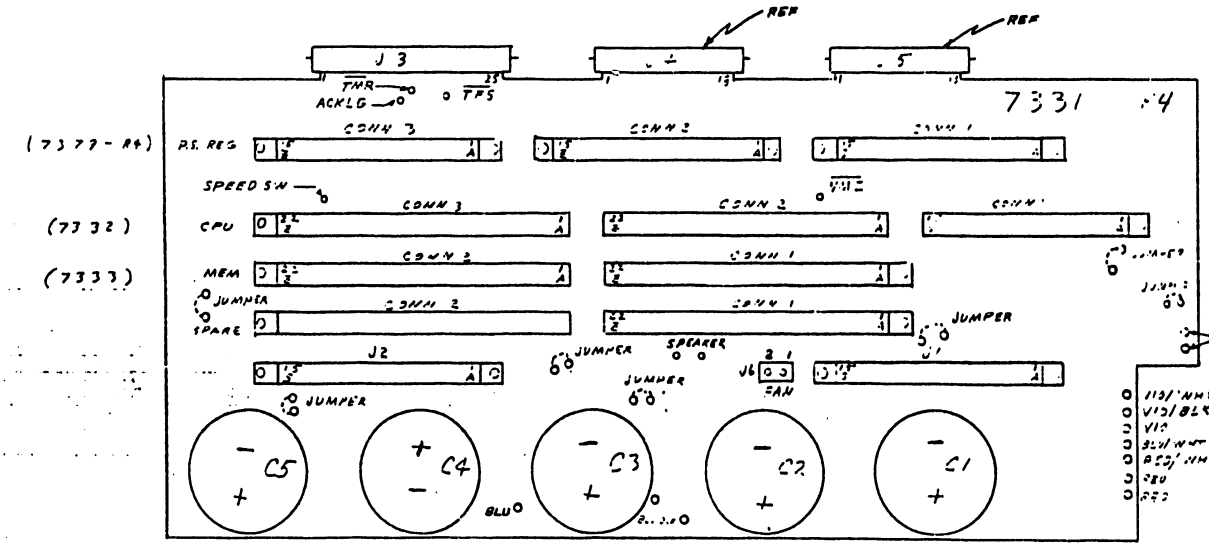

NO.	REVISION	DATE	BY	APPROVED BY
1	ORIG. DES. 1	12-15-78	J. J. ...	...
2	REVISED PER	12-15-78	...	...
3	APP'D. DES. 1	12-15-78	...	...
4	REVISED PER	12-15-78	...	...
5	APP'D. DES. 2	12-15-78	...	...
6	REVISED PER	12-15-78	...	...
7	APP'D. DES. 3	12-15-78	...	...
8	REVISED PER	12-15-78	...	...
9	APP'D. DES. 4	12-15-78	...	...
10	REVISED PER	12-15-78	...	...
11	APP'D. DES. 5	12-15-78	...	...

<b>WANG</b> LABORATORIES, INC. LOWELL, MASS. U.S.A.		BY	DATE	APPROVED BY	DATE
MATERIAL	MODEL NO. 3331W-5/6	...	...	...	...
FINISH	TOL. AS NOTED	TITLE 12 SOLENOID HEAD MOTOR BOARD			
PART NO. 3331W-5/6		DRAWING NO. 3331W-5/6		DATE 12-15-78	

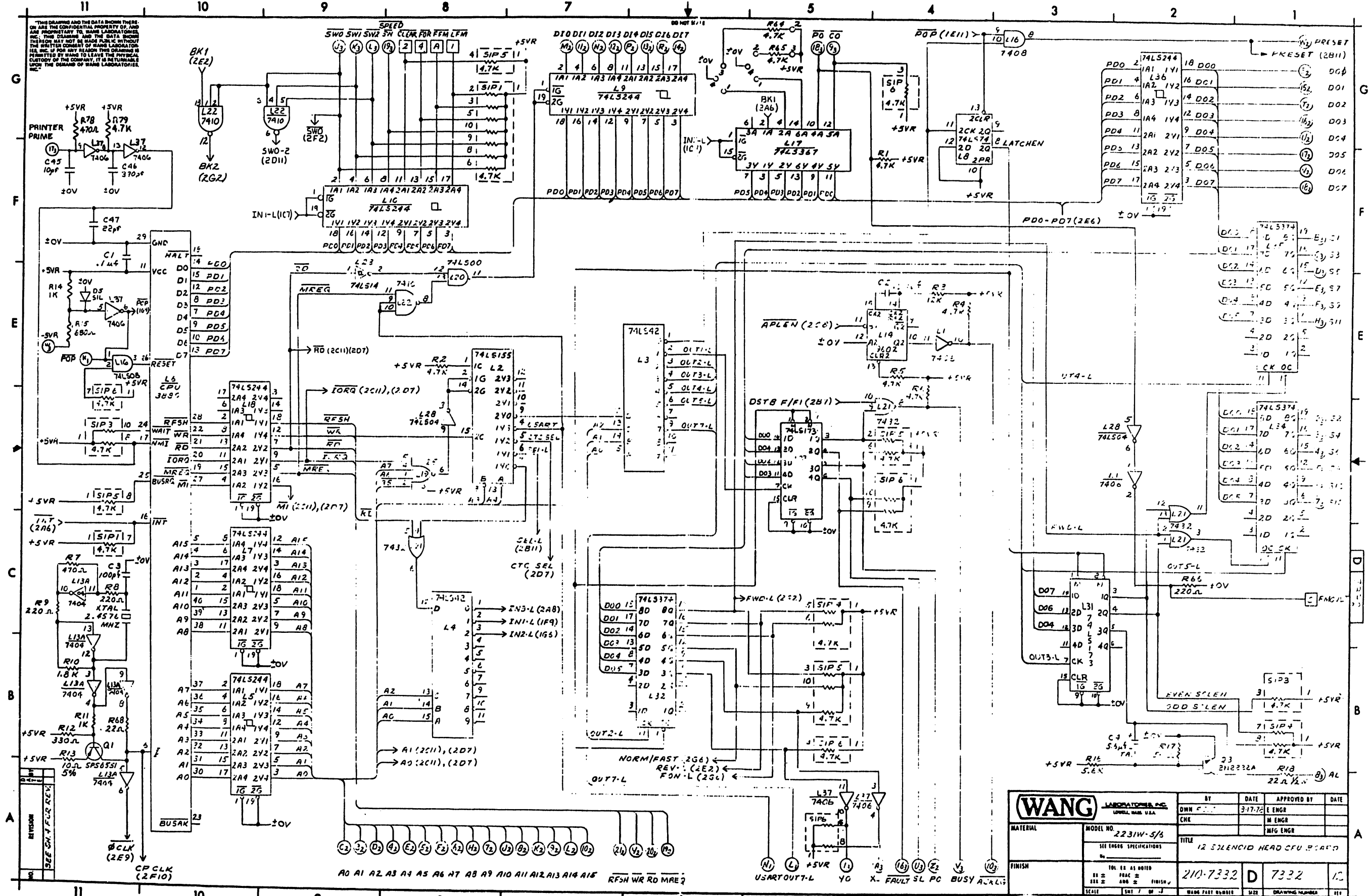

**TABLE 5-1**  
**LOCATION OF MAJOR ELECTRICAL ADJUSTMENTS**  
**AND TEST POINTS**

SYMBOL	ITEM	ELECTRICAL	PHYSICAL	DESCRIPTION
		LOCATION	LOCATION	
		7332-2	7332-4	
TP1	-12V	C,1	F,2	DC Voltage
TP2	+12V	C,1	F,3	DC Voltage
TP3	+0V	C,1	F,4	Ground
TP4	+5VR	C,1	F,5	DC Voltage
R22	50K Pot.	G,9	F,2	Window Strobe (Pulse Width) Adj. Para. 6.4, Page 6-3.
R55	100K Pot.	F,4	F,2	Window Strobe (Duty Cycle) Adj. Para. 6.4, Page 6-3.

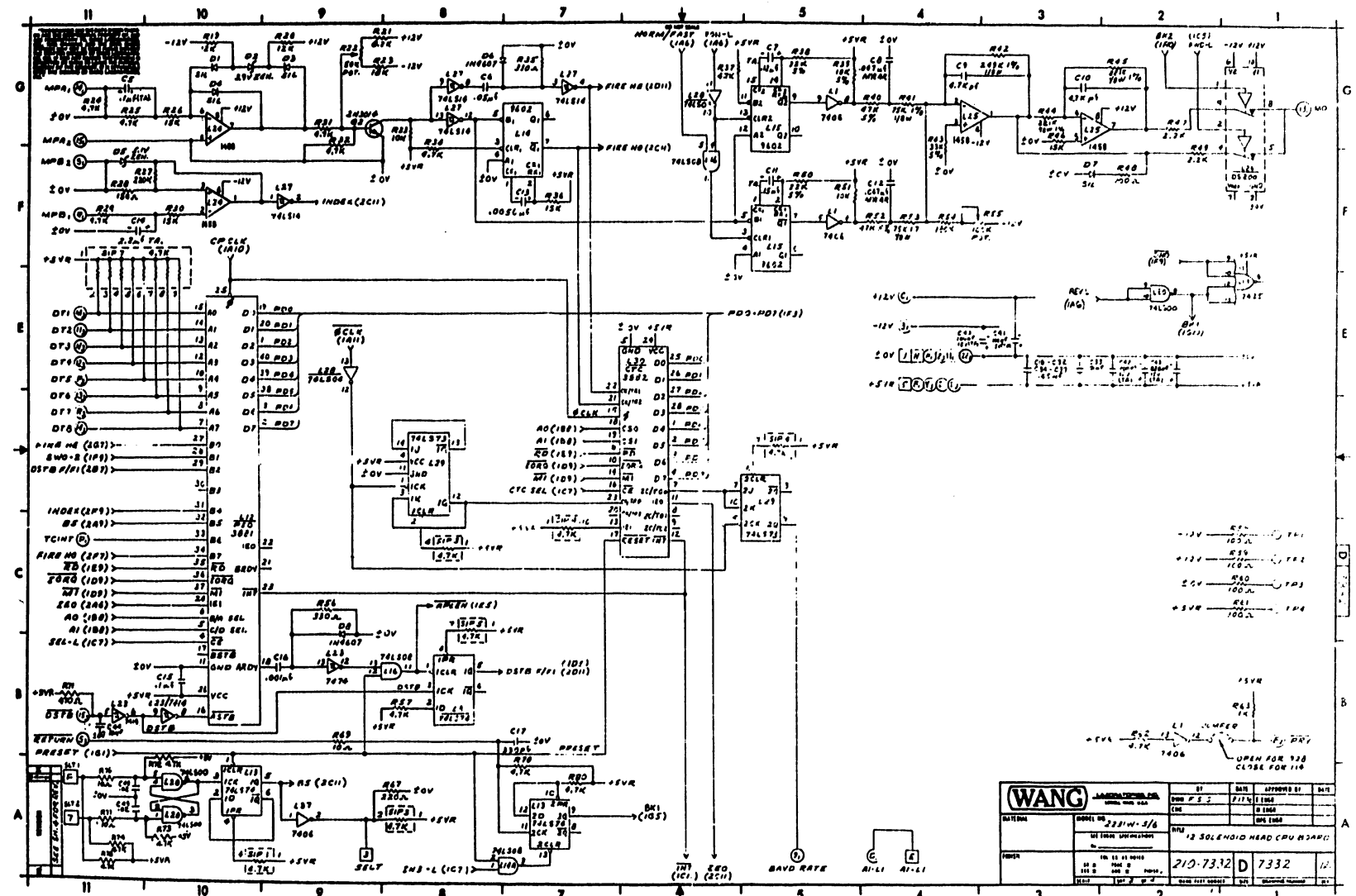

<b>WANG</b>		DATE	APPROVED BY
DESIGNER	DATE	DATE	DATE
REVISION	BY	DATE	DATE
210-7332		7332	



11 10 9 8 7 5 4 3 2 1

THE DRAWING AND THE DATA SHOWN THEREON ARE THE PROPRIETARY PROPERTY OF WANG LABORATORIES, INC. THIS DRAWING AND THE DATA SHOWN THEREON MAY NOT BE MADE PUBLIC WITHOUT THE WRITTEN CONSENT OF WANG LABORATORIES, INC. IN NO EVENT SHALL THE DRAWING OR DATA BE REPRODUCED OR TRANSMITTED IN ANY FORM OR BY ANY MEANS, ELECTRONIC OR MECHANICAL, INCLUDING PHOTOCOPYING, RECORDING, OR BY ANY INFORMATION STORAGE AND RETRIEVAL SYSTEM, WITHOUT THE WRITTEN PERMISSION OF WANG LABORATORIES, INC.

I.C. LOCATION	TYPE	W.L. NO.
L1,37	7406	376-0055
L2	74LS155	376-0158
L3,4	74LS42	376-0212
L5,7,9,10,18,36	74LS244	376-0288
L6	CPU 3880	SEE CHART
L8,13	74LS74	376-0155
L12	P10 3881	SEE CHART
L13A	7404	376-0010
L14,15	9602	376-0104
L16,L14A	74LS08	376-0153
L17	74LS367	376-0192
L19	7425	376-0092
L20	74LS00	376-0207
L21	7432	376-0093
L22	7410	376-0003
L23	7414	376-0139
L24,25	1458	376-0265
L26	D6200	376-0195
L27	74LS14	376-0322
L29	74LS04	376-0180
L29	74LS73	376-0304
L30	CYC 3892	SEE CHART
L32,34,35	74LS374	376-0286
L31, L33	74LS173	376-0289
L6,12 SKT.	40 PIN	376-9011
L30 SKT.	28 PIN	376-9015

LOCATION	TYPE	SPARES
L1	7406	1
L11	SPARE	
L22	7410	1
L23	7414	2
L28	74LS04	2

Z10 = 209 + 378 OR 377				
210	209	L6	L12	L30
7332-A	7332	377-0399	377-0392	377-0393

COMPONENT	TYPE	W.L. NO.
R1,2,4-6,24,25,29,31,32,34,37,57,62,64,65,74,72,73,74,75,79,80	4.7K 1/4W 10%	330-3047
R10	10K 1/4W 10%	330-3018
R3,19,20	12K 1/4W 10%	330-4012
R7,71,78	470K 1/4W 10%	330-2047
R8,9,66,67	220K 1/4W 10%	330-2022
R11,63,64	1K 1/4W 10%	330-3010
R12,35,56	330K 1/4W 10%	330-2033
R13	10K 1/4W 5%	330-1011
R16	5.6K 1/4W 10%	330-3056
R17	560K 1/4W 10%	330-2056
R18	22K 1/4W 10%	331-1022
R15	680K 1/4W 10%	330-2068
R21	8.2K 1/4W 10%	330-3082
R22	50K POT	336-1012
R23	18K 1/4W 10%	330-4016
R26,30,36,46	15K 1/4W 10%	330-4015
R27	220K 1/4W 10%	330-5022
R28	150K 1/4W 10%	330-2015
R33,51	10K 1/4W 10%	330-4010
R38,50	22K 1/4W 5%	330-4023
R39	10K 1/4W 5%	330-4011
R40,52	47K 1/4W 5%	330-4049
R41,53	75K 1/8W 1%	333-0054
R42	249K 1/8W 1%	333-0062
R43	33K 1/4W 5%	330-4034
R68	22K 1/4W 10%	330-1022
R44,45	22.1K 1/8W 1%	333-0018
R47,49	2.2K 1/4W 10%	330-3022
R48,58-61	100K 1/4W 10%	330-2010
R54	180K 1/4W 10%	330-5018
R55	100K POT	336-1019
SIP1, SIP3-7	4.7K	333-0812
J1	20 PIN	350-0028

COMPONENT	TYPE	W.L. NO.
C1,15	.1uF 50V	300-1930
C2,16	.001uF 500V	300-1906
C3	100uF 500V	300-1100
C33	.01uF 25V	300-1903
C4	5.6uF 35V TA	300-4017
C5	.1uF 35V TA	300-4002
C6,18-32,34-39	.05uF 12V	300-1900
C7	.12uF 35V TA	300-4003
C17	330uF 500V	300-1330
C8,12	.047uF 50V WTLN	300-2147
C9,10	4.7K 100V	300-1932
C11	.15uF 35V TA	300-4004
C13	.0056uF 500V	300-1915
C14	22uF 20V TA	300-4014
C40,41	100uF 15V TA	300-4021
C12,43	220uF 15V TA	300-4049
D1,3-5	SIL	380-1001
D2	3.9V ZENER	380-2035
D5	5.1V ZENER	380-2051
D6,8	1N4507	380-1005
G1	SP56551	375-1350
G2	2113014	375-0517
G3	2N2222A	375-1005
XTAL	8.4576MHZ	321-0027
C44,45	10uF 500V	300-1010
C46	370uF 500V	300-1390
C47	22uF	300-1022
C48,49	.02uF 25V	300-1904

MNEMONIC	COORD
AO-A15	1A8
AI-L1	2A4
ACKLG	1A3
AL	1A1
BAVD RATE	2A5
BUSV	1A4
CLEAR	1G8
CO	1G5
DOO-D07	1G1
DIO-D17	2G7
DSTB	2B11
DT1-D18	2E11
FAULT	1A4
FFM	1G8
FMOVL	1G1
FOR	1G8
LFM	1G8
NO	2G1
MPA1	2G11
MPA2	2G11
MPB1	2F11
MPB2	2F11
MREQ	1A6
OUT-L	1A5
PO	1A4
POP	1G5
PRESET	1G1
PRINTER PRIME	1F11
PRV	2A1
RD	1A6
RETURN	2B11
RFSH	1A7
SI-S12	1A1
SELT	2A9
SL	1A4
SLT1	2A11
SLT2	2A11
SPEED SW	1G8
SWO	1G9
SW1	1G9
SW2	1G9
TCINT	2C11
USART	1A5
WR	1A6
XO	1A4
YO	1A5

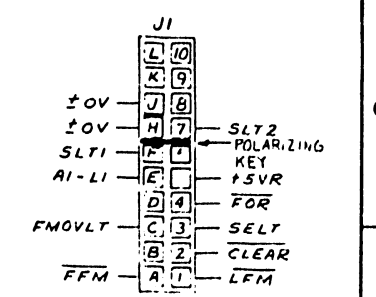
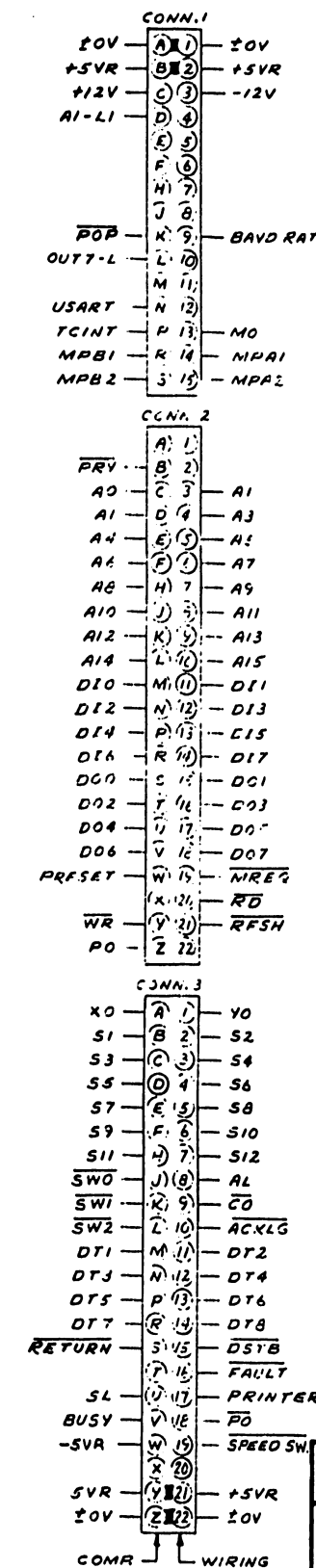

<b>WANG</b> LABORATORIES, INC. LONDON, ENGLAND		BY DWN F.S.S.	DATE 8/17/78	APPROVED BY E ENGR	DATE
MATERIAL	MODEL NO. 2231W-5/6	CHE		M ENGR	
FINISH	SITE ENGR. SPECIFICATIONS	TITLE 12 SOLENOID HEAD CPU BOARD			
VOL. 11, 45 NOTED 111 22 SCALE 1:1		210-7332 7332		12 7332	

THIS DRAWING AND THE DATA SHOWN THEREON ARE THE CONFIDENTIAL PROPERTY OF WANG LABORATORIES, INC. AND ARE NOT TO BE REPRODUCED OR TRANSMITTED IN ANY FORM OR BY ANY MEANS, ELECTRONIC OR MECHANICAL, INCLUDING PHOTOCOPYING, RECORDING, OR BY ANY INFORMATION STORAGE AND RETRIEVAL SYSTEM. THE USER OF THIS DRAWING IS TO BE RESPONSIBLE FOR THE PROTECTION OF THE CONFIDENTIALITY OF THE INFORMATION CONTAINED HEREON.

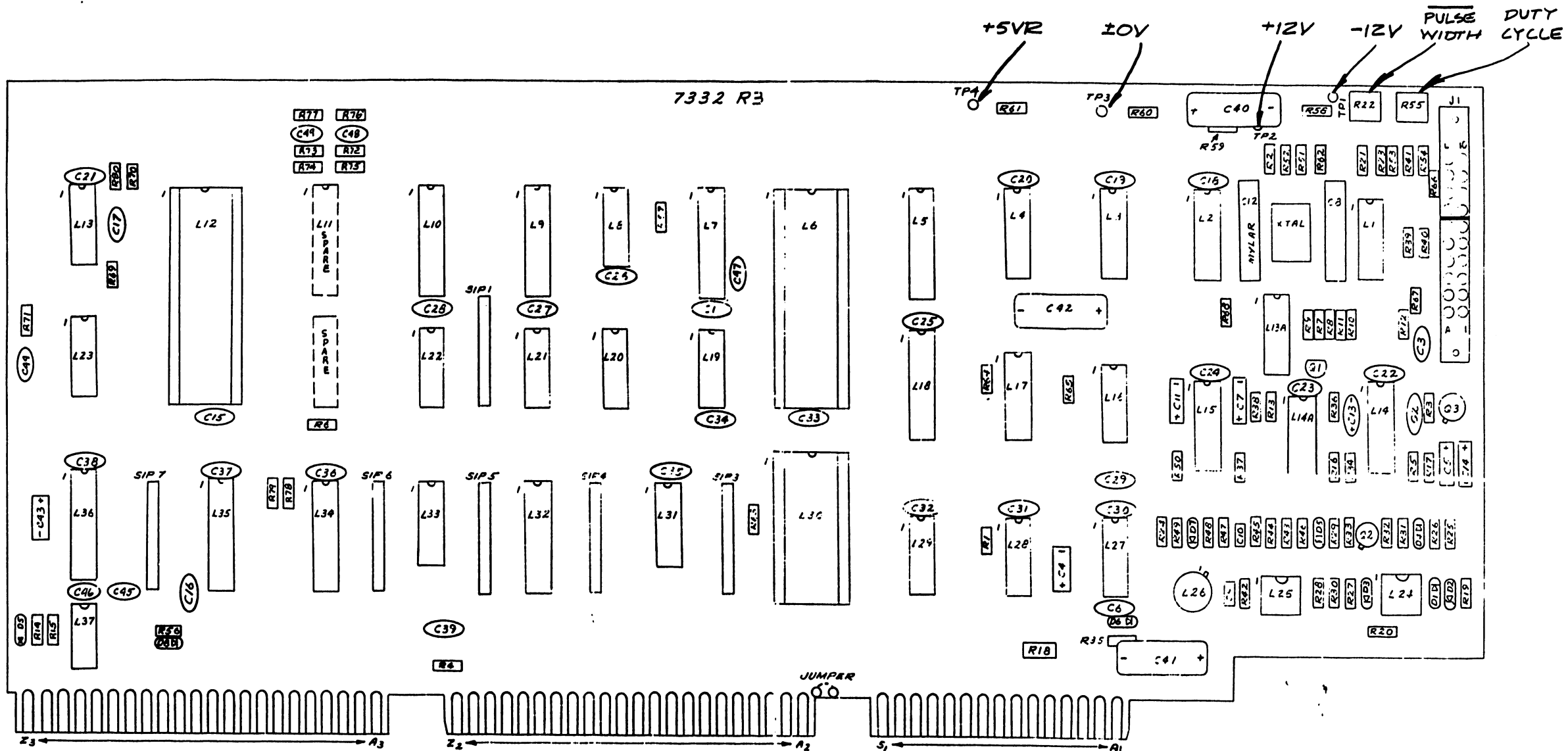

REV	DATE	BY	DESCRIPTION
1	11-17-72	WSS	ORIGINAL PER APP'D
2	11-17-72	WSS	REVISED PER ECN # 11231
3	11-17-72	WSS	REVISED PER ECN # 11232
4	11-17-72	WSS	REVISED PER ECN # 11233
5	11-17-72	WSS	REVISED PER ECN # 11234
6	11-17-72	WSS	REVISED PER ECN # 11235
7	11-17-72	WSS	REVISED PER ECN # 11236
8	11-17-72	WSS	REVISED PER ECN # 11237
9	11-17-72	WSS	REVISED PER ECN # 11238
10	11-17-72	WSS	REVISED PER ECN # 11239
11	11-17-72	WSS	REVISED PER ECN # 11240
12	11-17-72	WSS	REVISED PER ECN # 11241
13	11-17-72	WSS	REVISED PER ECN # 11242
14	11-17-72	WSS	REVISED PER ECN # 11243
15	11-17-72	WSS	REVISED PER ECN # 11244
16	11-17-72	WSS	REVISED PER ECN # 11245

7332 E-REV 8  
7332-A E-REV 8

<b>WANG</b> LABORATORIES, INC. LOWELL, MASS. U.S.A.		BY DWN F.S.S.	DATE 8-17-72	APPROVED BY E. ENGR. D. THERRAN	DATE 11-17-72
MATERIAL	MODEL NO. 2231W-5/6	TITLE 12 SOLENOID HEAD CPU BOARD		MFG ENGR	
FINISH	SEE ENGR. SPECIFICATIONS	210-7332		7332	12
SCALE 1:1		WANG PART NUMBER		SIZE	DRAWING NUMBER

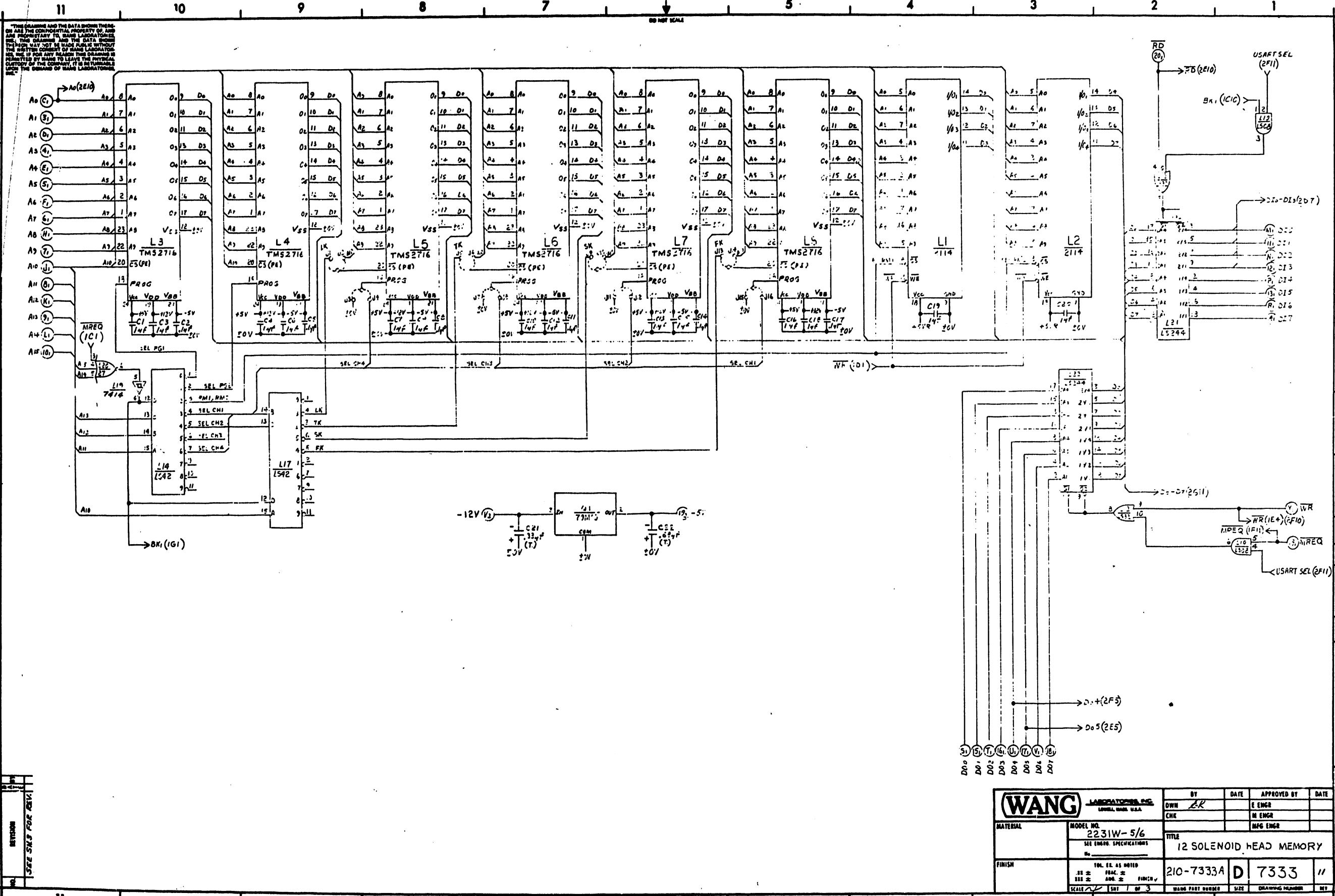

"THIS DRAWING AND THE DATA HEREIN THEREON ARE THE CONFIDENTIAL PROPERTY OF WANG AND PROPRIETARY TO WANG LABORATORIES, INC. THIS DRAWING AND THE DATA HEREON MAY NOT BE MADE PUBLIC WITHOUT THE WRITTEN CONSENT OF WANG LABORATORIES, INC. IF FOR ANY REASON THIS DRAWING IS REPRODUCED BY ANYONE TO LEAVE THE POSSESSION OF THE COMPANY, IT IS TO REMAIN THE PROPERTY OF WANG LABORATORIES, INC."

<b>WANG</b> LABORATORIES, INC. LOWELL, MASS. U.S.A.		BY	DATE	APPROVED BY	DATE
MATERIAL	MODEL NO. 2231W-5/6	OWN	ENGR		
	SEE ENGR. SPECIFICATIONS	CHK	M ENGR		
			MPG ENGR		
FINISH	TOL. EE. AS NOTED	TITLE		12 SOLENOID HEAD MEMORY	
	30 ±	210-7333A D 7333		11	
	100 ±	WANG PART NUMBER		SIZE	DRAWING NUMBER
	SCALE	1/8" = 1"		OF 3	REV

11 10 9 8 7 5 4 3 2 1

THIS DRAWING AND THE DATA THEREON ARE THE PROPRIETARY PROPERTY OF WANG AND SHOULD BE KEPT SECRET. IT IS TO BE USED ONLY FOR THE PURPOSES SPECIFIED HEREIN. THE USER MAY NOT REPRODUCE OR TRANSMIT THIS DRAWING OR THE DATA THEREON IN ANY FORM OR BY ANY MEANS, ELECTRONIC OR MECHANICAL, INCLUDING PHOTOCOPYING, RECORDING, OR BY ANY INFORMATION STORAGE AND RETRIEVAL SYSTEM, WITHOUT THE WRITTEN PERMISSION OF WANG LABORATORIES, INC. IN THE EVENT OF ANY VIOLATION OF THIS AGREEMENT, THE USER SHALL BE LIABLE TO WANG LABORATORIES, INC. FOR ALL DAMAGES, INCLUDING REASONABLE ATTORNEY'S FEES AND COSTS OF LITIGATION.

DO NOT SCALE

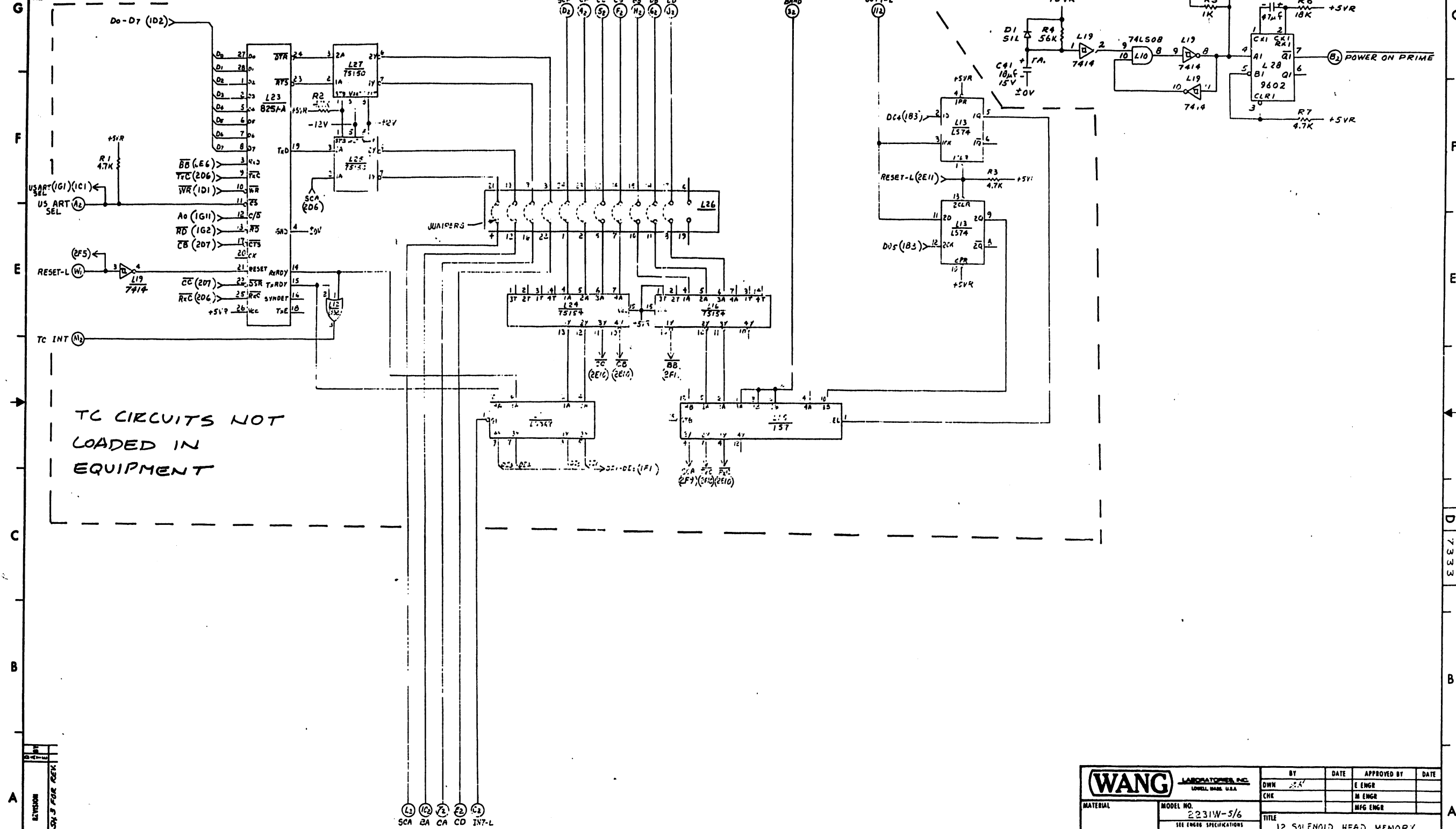

TC CIRCUITS NOT LOADED IN EQUIPMENT

SEE DR. 3 FOR REFK

<b>WANG</b> LABORATORIES, INC. LOWELL, MASS. U.S.A.		BY DWN	DATE 2/6	APPROVED BY E ENGR	DATE
MATERIAL	MODEL NO. 2231W-5/6	CHK		M ENGR	
SEE ENGR SPECIFICATIONS		TITLE 12 SOLENOID HEAD MEMORY			
FINISH	TOI. EX. AS NOTED	210-7333A	D	7333	11
SCALE: 1" = 1"		WANG PART NUMBER	SIZE	DRAWING NUMBER	REV

11 10 9 8 7 5 4 3 2 1

"THE DRAWING AND THE DATA SHOWN THEREON ARE THE CONFIDENTIAL PROPERTY OF, AND ARE PROPRIETARY TO, WANG LABORATORIES, INC. THIS DRAWING AND THE DATA SHOWN THEREON MAY NOT BE MADE PUBLIC WITHOUT THE WRITTEN CONSENT OF WANG LABORATORIES, INC. IF FOR ANY REASON THIS DRAWING IS PERMITTED BY WANG TO LEAVE THE PHYSICAL CUSTODY OF THE COMPANY, IT IS RETURNABLE UPON THE DEMAND OF WANG LABORATORIES, INC."

DO NOT SCALE

COMPONENT	W.L. PART NO.	TYPE
C1,3,4,6,7,9,10,12,13,15,16,18,19,20,22	733-1931	14F 50V
C2,5,8,11,14,17	300-1930	14F 50V
C21	300-4028	1.33uF 35V (T)
C22	300-4028	6.2uF 35V (T)
C23-36	300-1900	10uF 2
C37-40	300-4022	15uF 20V (T)
C41	300-4018	18uF 15V (T)
C43	300-4020	47uF 15V (T)
R1,3,7	330-3047	4.7K 1/4W
R4	330-4056	56K 1/4W
R5	330-3010	1K 1/4W
R6	330-4018	18K 1/4W
R2	SEE CHART	
Q1	374-3002	73M05
D1	380-1001	51L

LOCATION	W.L. PART NO.	TYPE
L1,2	SEE CHART	2114
L3,4,5,6,7,8	SEE CHART	TMS-716
L10	376-0153	74LS02
L11	376-0172	74LS367
L12	376-0211	74LS32
L13	376-0155	74LS74
L14,17	376-0212	74LS42
L15	376-0092	74157
L16,24	376-0077	75151
L17	376-0134	7414
L20	376-0125	7427
L21,22	376-0283	74LS244
L23	SEE CHART	8251-A
L25,27	376-0076	75150
L28	376-C104	9602
L19,18		STARE
L1,2	376-9014	18 PIN SKT
L3-8	376-9003	24 PIN SKT
L23	376-9015	26 PIN SKT

MEMORIC	COORDINATE
A0-A15	1F11
BA	2A8
BB	2G7
CA	2A8
CB	2G7
CC	2G7
CD	2A8
CE	2G7
DB	2G7
DD	251
DC1	1R3
DI1	1F
INT-L	2A8
INT-R	101
INT-L	255
INT-R	251
INT-L	150
INT-R	251
INT-L	2A8
INT-R	257
INT-L	256
INT-R	2611
INT-L	251
INT-R	251

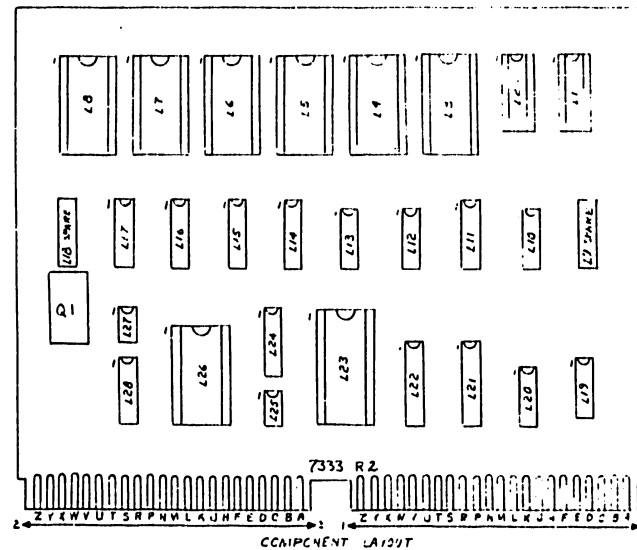
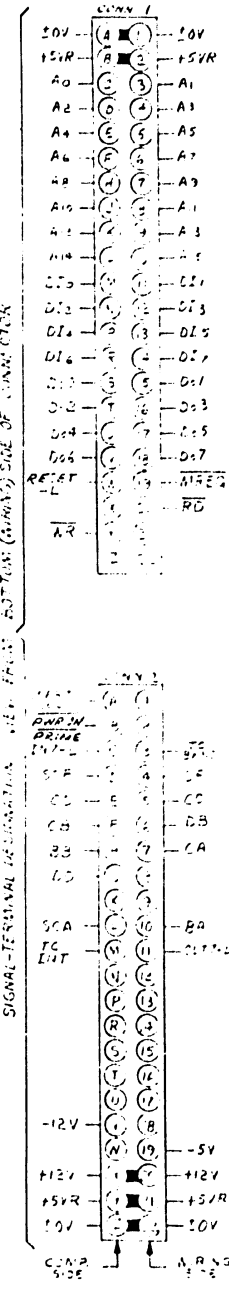

LOCATION	TYPE	SPACE
L15	74LS32	1
L1	74LS247	2
L12	74LS32	1
L7	7414	1
L23	7427	2
L28	9602	1



MODEL	210	209	L1,2	L3	L4	L5	L6	L7	L8	L11	L13	L15	L16,24	L23	L25,27	R2
31 W-5/6 12 SOL MEM	7333A	7333	377-0341L	378-4002R7	378-4003R7			378-4005R7	378-4004R7							
31 W-7/6 12 SOL MEM	7333A	7333	377-0341L	378-4002R7	378-4003R7			378-4005R7	378-4004R7	376-0192	376-0155	376-0082	376-0077	377-0352	376-0076	330
31 W-6 12 SOL MEM	7333B	7333		378-4002R7	378-4003R7			378-4009	378-4090							

REVISION	DATE	BY	DESCRIPTION
0	10-14-73	AK	ORIGINATED PER DWG 4005-12-12
1	10-14-73	AK	REVISED PER 4005-12-12
2	10-14-73	AK	REVISED PER 4005-12-12
3	10-14-73	AK	REVISED PER 4005-12-12
4	10-14-73	AK	REVISED PER 4005-12-12
5	10-14-73	AK	REVISED PER 4005-12-12
6	10-14-73	AK	REVISED PER 4005-12-12
7	10-14-73	AK	REVISED PER 4005-12-12
8	10-14-73	AK	REVISED PER 4005-12-12
9	10-14-73	AK	REVISED PER 4005-12-12
10	10-14-73	AK	REVISED PER 4005-12-12
11	10-14-73	AK	REVISED PER 4005-12-12

<b>WANG</b> LABORATORIES, INC. LOWELL, MASS. U.S.A.		BY: DWN	DATE: 5-11-73	APPROVED BY: E. ENGT-ERRIAN	DATE: 5/11/73
MATERIAL: MODEL NO. 2231W-5/6 SEE ENGINE SPECIFICATIONS		CHE: G.D.	DATE: 5/11/73	M. ENGR.	
FINISH: TOL. AS NOTED DIM. AS NOTED SCALE: 1/8" = 1"		TITLE: 12 SOLENOID HEAD MEMORY		WFG ENGR.	
PART NUMBER: 7333		DRAWING NUMBER: D 7333		REV: 11	

**TABLE 5-2**  
**LOCATION OF MAJOR ELECTRICAL ADJUSTMENTS**  
**AND TEST POINTS**

SYMBOL	ITEM	ELECTRICAL	PHYSICAL	DESCRIPTION
		LOCATION	LOCATION	
		7379-1	7379-2	
R24	1K Pot.	F,3	D,8	+5VR Adjustment

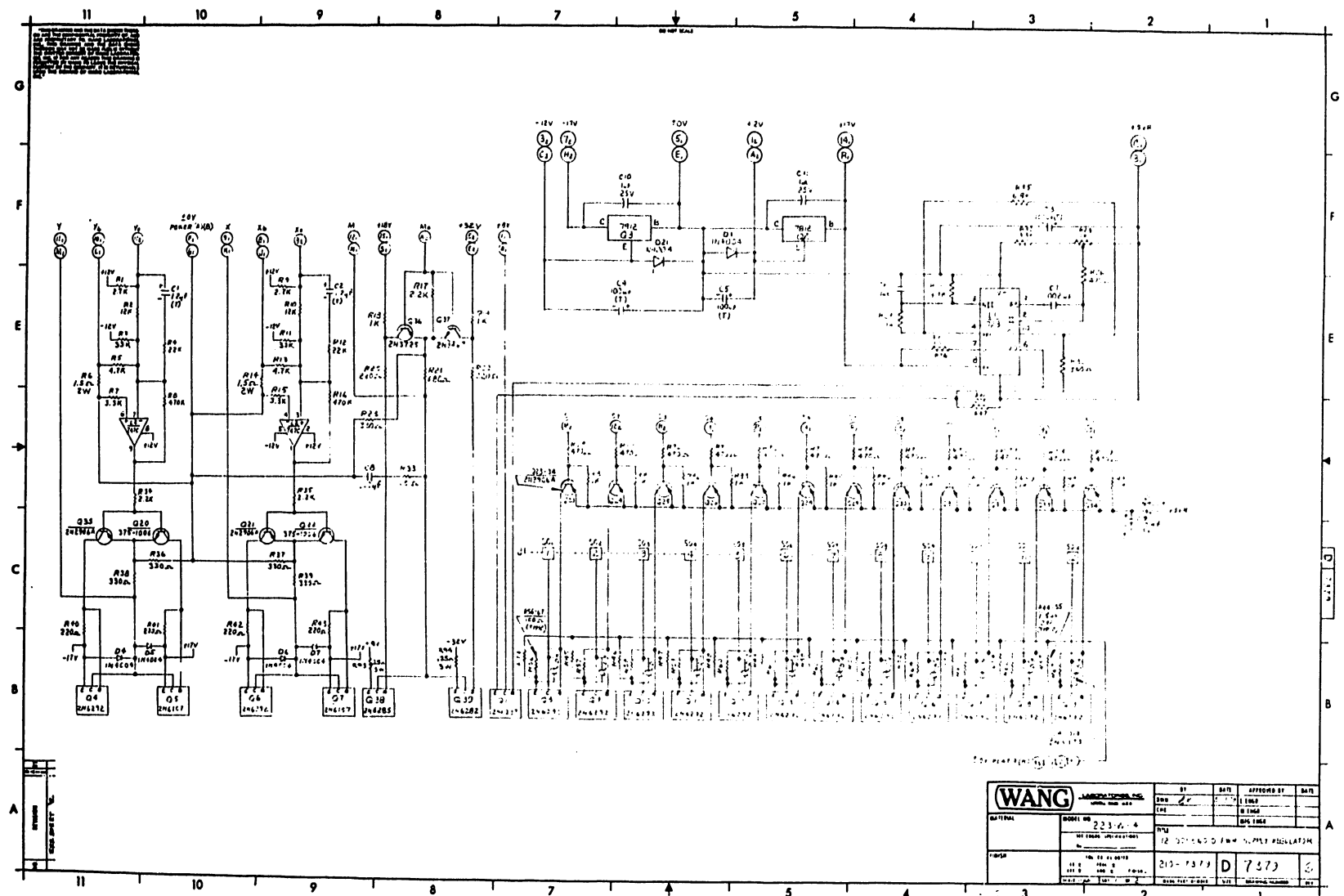

11 10 9 8 7 6 5 4 3 2 1

THIS DRAWING AND THE DATA SHOWN THEREON ARE THE PROPERTY OF WANG LABORATORIES, INC. AND ARE PROPRIETARY TO WANG LABORATORIES, INC. THE DRAWING AND THE DATA SHOWN THEREON MAY NOT BE MADE PUBLIC WITHOUT THE WRITTEN CONSENT OF WANG LABORATORIES, INC. IF FOR ANY REASON THIS DRAWING IS PERMITTED BY WANG TO LEAVE THE PHYSICAL POSSESSION OF THE COMPANY, IT IS RETURNABLE UPON THE DEMAND OF WANG LABORATORIES, INC.

DO NOT SCALE

COMPONENT	U.L. PART NO	TYPE
R1, 9, 29	330-3027	2.7K 10%
R2, 10	330-4012	12K 10%
R3, 11	330-4033	33K 10%
R4, 12	330-4322	22K 10%
R5, 13	330-3047	4.7K 10%
R6, 14, 44-55	334-0026	1.5% 2W 1%
R7, 15, 92	330-3033	3.3K 10%
R8, 16	330-5047	470K 10%
R17, 34, 35	330-3022	3.2K 10%
R18, 17, 80-91	330-3010	1K 10%
R20, 22, 40-43	330-2022	220Ω 1%
R21	330-2068	680Ω 1%
R23, 36-37	330-2033	330Ω 10%
R24	336-1014	1K TRIM POT
R25	330-3039	3.9K 10%
R33	730-1010	5Ω 1%
R54-67	330-2010	100Ω 1%
P22 62-79	330-2047	470Ω 10%
P32	330-2756	560Ω 1%
R95	330-0068	68K 10%
R76	332-0037	375Ω 1W 10%
R77	330-0035	35Ω 3W 10%
C1, 2	300-4013	1.24F 35V
C3, 4, 5, 9	300-1521	100μF 15V
C6	300-1701	1μF 12V
C7	300-1713	0.024F 500V
C8	300-1726	22μF 100V
C10, 11	300-1000	1.04F 35V
T1	350-0042	201M
D1, 4, 5, 6, 7, 20, 21	320-4000	1N4004
D8-19	380-2131	1N5373
Q1	375-1054	2N5387
Q2	374-0007	UA7912
Q4, 6, 7-19	375-1051	2N6272
Q3	374-0003	UA7912
Q20, 22	375-1006	5R17E9
Q21, 23-25	375-1017	2N2936A
Q35	375-1027	2N3725
Q37	375-1026	2N3467
Q5, 7	375-1053	2N6107
Q38, 39	375-3010	HEATSINK
R73, 94	334-0017	.15% 3W
KEY	350-4118	
Q28	375-1047	2N6235
Q29	375-1046	2N6292

LOCATION	U.L. PART NO.	TYPE
L1	376-0046	723
L2	376-0187	72747

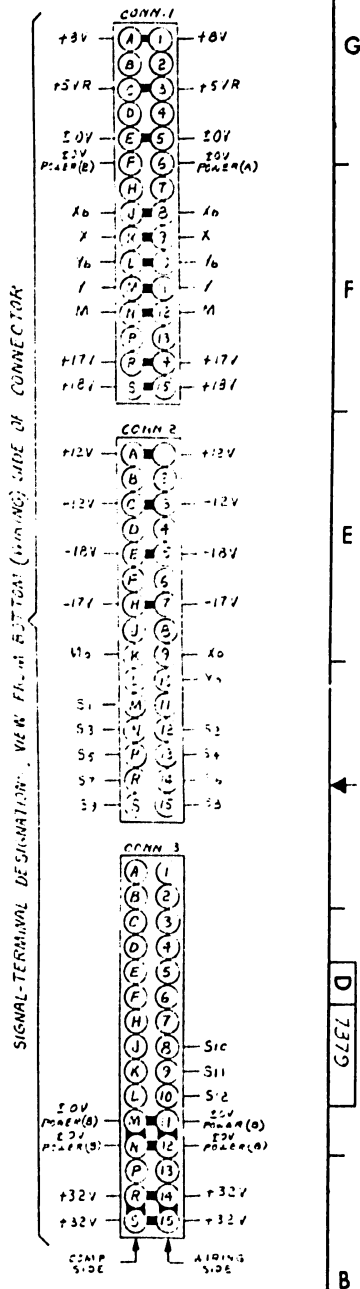
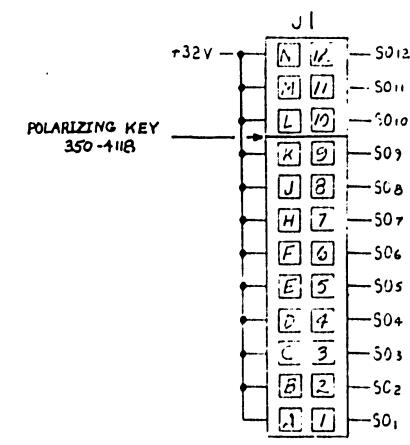
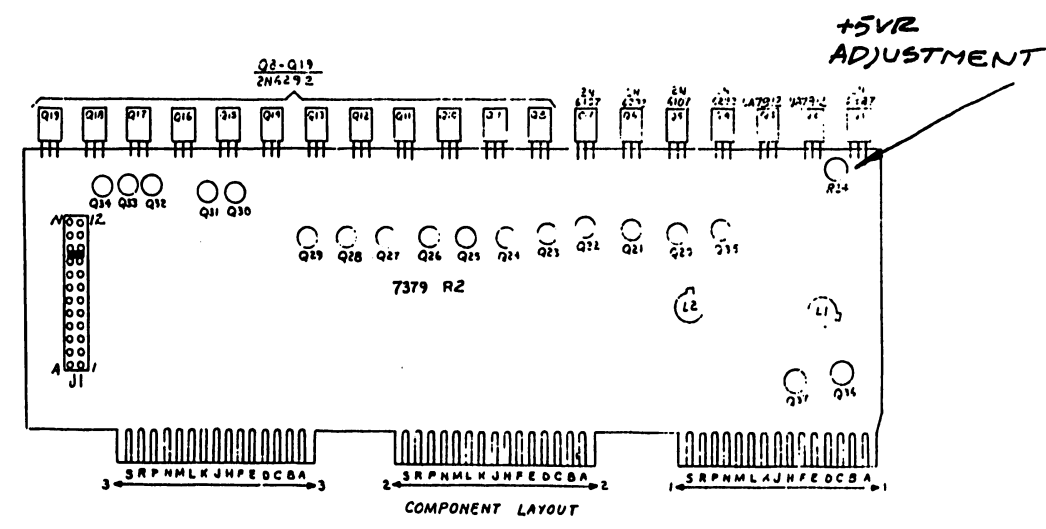

REV	DATE	BY	DESCRIPTION
0	5-12-78	EM	ORIGINATED FOR
1	5-12-78	EM	CHG. FROM 1000
2	5-12-78	EM	REV. PER 1000
3	5-12-78	EM	REV. PER 1000
4	5-12-78	EM	REV. PER 1000
5	5-12-78	EM	REV. PER 1000
6	5-12-78	EM	REV. PER 1000
7	5-12-78	EM	REV. PER 1000
8	5-12-78	EM	REV. PER 1000
9	5-12-78	EM	REV. PER 1000
10	5-12-78	EM	REV. PER 1000
11	5-12-78	EM	REV. PER 1000

<b>WANG</b> LABORATORIES, INC. LOWELL, MASS. U.S.A.		BY: DWN / K	DATE: 5-12-78	APPROVED BY: E. ENGRD. T. ENGR	DATE: 6-28-78
MATERIAL:	MODEL NO. 2231W-4	CHK: G.D.	DATE: 6/1/78	BY: M ENGR	
FINISH:	SEE ENGR SPECIFICATIONS	TITLE: 12 SOLENOID PWR SUPPLY REGULATOR			
	10L AS NOTED	210-7379	D	7379	6
	11 ± .005	210-7379	D	7379	6
	12 ± .005	210-7379	D	7379	6
	13 ± .005	210-7379	D	7379	6
	14 ± .005	210-7379	D	7379	6
	15 ± .005	210-7379	D	7379	6
	16 ± .005	210-7379	D	7379	6
	17 ± .005	210-7379	D	7379	6
	18 ± .005	210-7379	D	7379	6
	19 ± .005	210-7379	D	7379	6
	20 ± .005	210-7379	D	7379	6
	21 ± .005	210-7379	D	7379	6
	22 ± .005	210-7379	D	7379	6
	23 ± .005	210-7379	D	7379	6
	24 ± .005	210-7379	D	7379	6
	25 ± .005	210-7379	D	7379	6
	26 ± .005	210-7379	D	7379	6
	27 ± .005	210-7379	D	7379	6
	28 ± .005	210-7379	D	7379	6
	29 ± .005	210-7379	D	7379	6
	30 ± .005	210-7379	D	7379	6
	31 ± .005	210-7379	D	7379	6
	32 ± .005	210-7379	D	7379	6
	33 ± .005	210-7379	D	7379	6
	34 ± .005	210-7379	D	7379	6
	35 ± .005	210-7379	D	7379	6
	36 ± .005	210-7379	D	7379	6
	37 ± .005	210-7379	D	7379	6
	38 ± .005	210-7379	D	7379	6
	39 ± .005	210-7379	D	7379	6
	40 ± .005	210-7379	D	7379	6
	41 ± .005	210-7379	D	7379	6
	42 ± .005	210-7379	D	7379	6
	43 ± .005	210-7379	D	7379	6
	44 ± .005	210-7379	D	7379	6
	45 ± .005	210-7379	D	7379	6
	46 ± .005	210-7379	D	7379	6
	47 ± .005	210-7379	D	7379	6
	48 ± .005	210-7379	D	7379	6
	49 ± .005	210-7379	D	7379	6
	50 ± .005	210-7379	D	7379	6

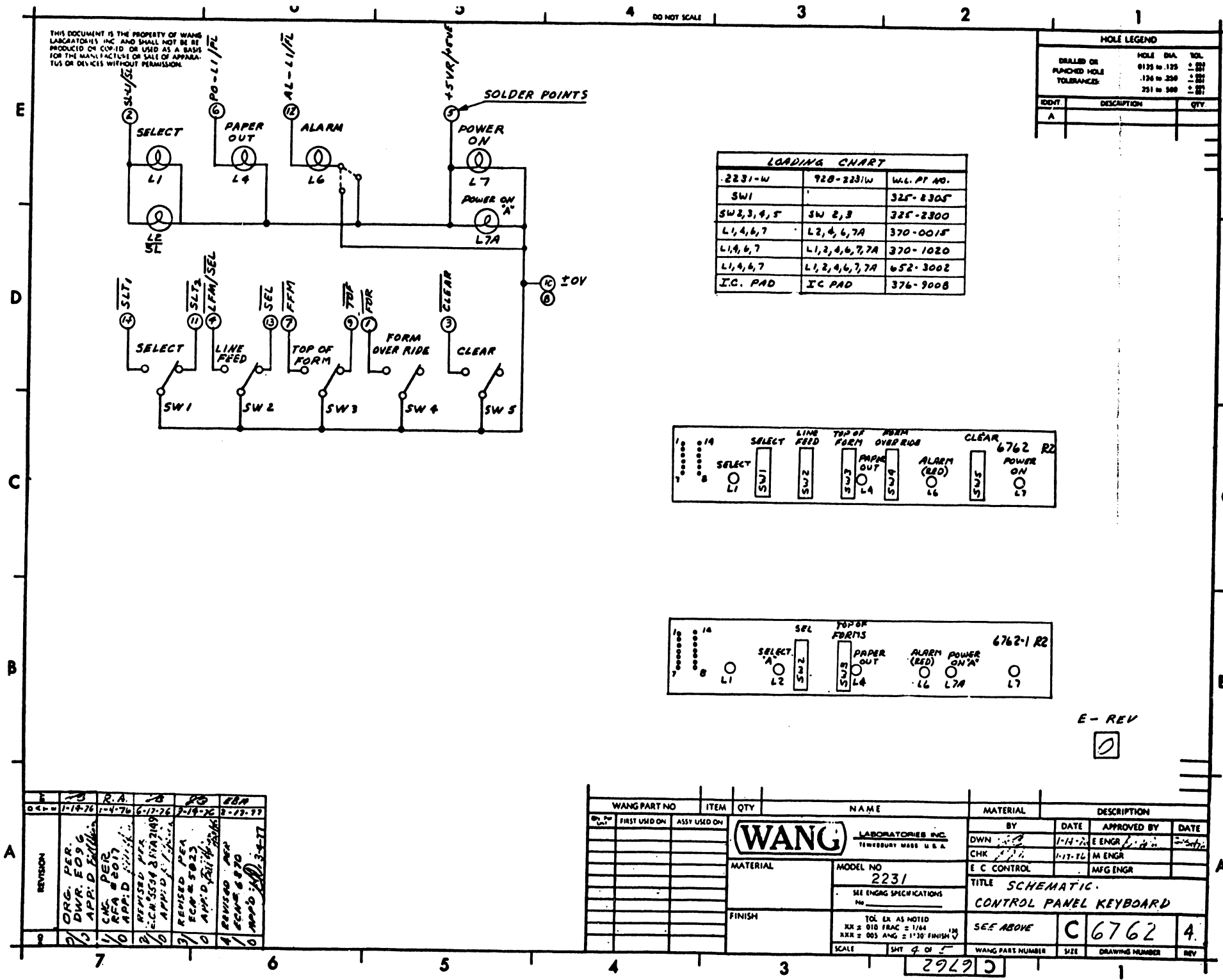

HOLE LEGEND		
DRILLED OR PUNCHED HOLE TOLERANCES:	HOLE DIA.	TOL.
	0.125 to .125	±.002
	.126 to .250	±.003
	.251 to .500	±.004
IDNT	DESCRIPTION	QTY
A		

LOADING CHART		
2231-W	920-2231W	W.L. PT NO.
SW 1		325-8305
SW 2,3,4,5	SW 2,3	325-2300
L 1,4,6,7	L 2,4,6,7A	370-0015
L 1,4,6,7	L 1,2,4,6,7,7A	370-1020
L 1,4,6,7	L 1,2,4,6,7,7A	652-3002
I.C. PAD	I.C. PAD	376-9008

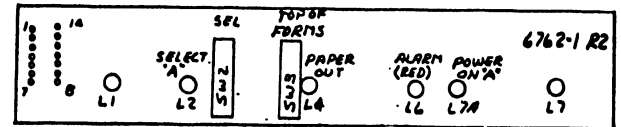
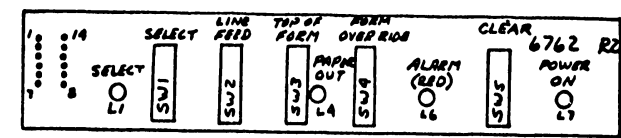

E-REV  
0

REV	DATE	BY	DESCRIPTION
1	1-14-76	R.A.	ORG. PER. DWR. EDS. G. APP. D. FULLER
2	1-4-76		CHE. PER. RFA #2017 APP. D. FULLER
3	6-17-76		REVISED PER. ECN #5013 APP. D. FULLER
4	7-19-76		REVISED PER. ECN #5023 APP. D. FULLER
5	8-13-77		REVISED PER. ECN #5020 APP. D. FULLER

WANG PART NO.	ITEM	QTY	NAME	MATERIAL	DESCRIPTION
2231			WANG LABORATORIES INC. TEMPE, ARIZ. MADE U.S.A.		
			MODEL NO. 2231		
			SEE ENG'G SPECIFICATIONS		
			FINISH		
			TOL. EX. AS NOTED		
			XX ± 0.10 TRAC ± 1/64		
			XXX ± 0.05 ANG ± 1/30 FINISH		
			SCALE		
			SMT 4 OF 5		
			WANG PART NUMBER		
			SIZE		
			DRAWING NUMBER		
			REV		



**END**