

**CUSTOMER
ENGINEERING**

**MODEL 2211M
PRINTER/PLOTTER
MULTIPLEXER**

**MAINTENANCE
MANUAL**

NOTICE:

This document is the property of Wang Laboratories, Inc. Information contained herein is considered company proprietary information and its use is restricted solely to the purpose of assisting you in servicing Wang products. Reproduction of all or any part of this document is prohibited without the consent of Wang Laboratories.

WANG

LABORATORIES, INC.

ONE INDUSTRIAL AVENUE, LOWELL, MASSACHUSETTS 01851, TEL. (617) 459-5000, TWX 710 343-6769, TELEX 94-7421

TABLE OF CONTENTS

| | | |
|-----------|---|-----|
| SECTION 1 | DESCRIPTION | 1-1 |
| 1.1 | GENERAL | 1-1 |
| 1.2 | SPECIFICATIONS | 1-2 |
| SECTION 2 | UNPACKING AND INCOMING INSPECTION | 2-1 |
| SECTION 3 | INITIAL SETUP | 3-1 |
| SECTION 4 | THEORY OF OPERATION (BLOCK LEVEL) | 4-1 |
| 4.1 | GENERAL | 4-1 |
| 4.2 | POWER-ON | 4-1 |
| 4.3 | CHANNEL-SELECTION | 4-1 |
| 4.4 | PROTECT-DELAY | 4-2 |
| 4.5 | SIGNAL MNEMONICS | 4-2 |
| SECTION 5 | DIAGNOSTIC TESTING PROCEDURES | 5-1 |
| 5.1 | PRELIMINARY CHECK | 5-1 |
| 5.2 | PRINTER/PLOTTER DIAGNOSTIC | 5-1 |
| SECTION 6 | TROUBLESHOOTING | 6-1 |
| SECTION 7 | BILL OF MATERIALS | 7-1 |
| SECTION 8 | SCHEMATICS | 8-1 |

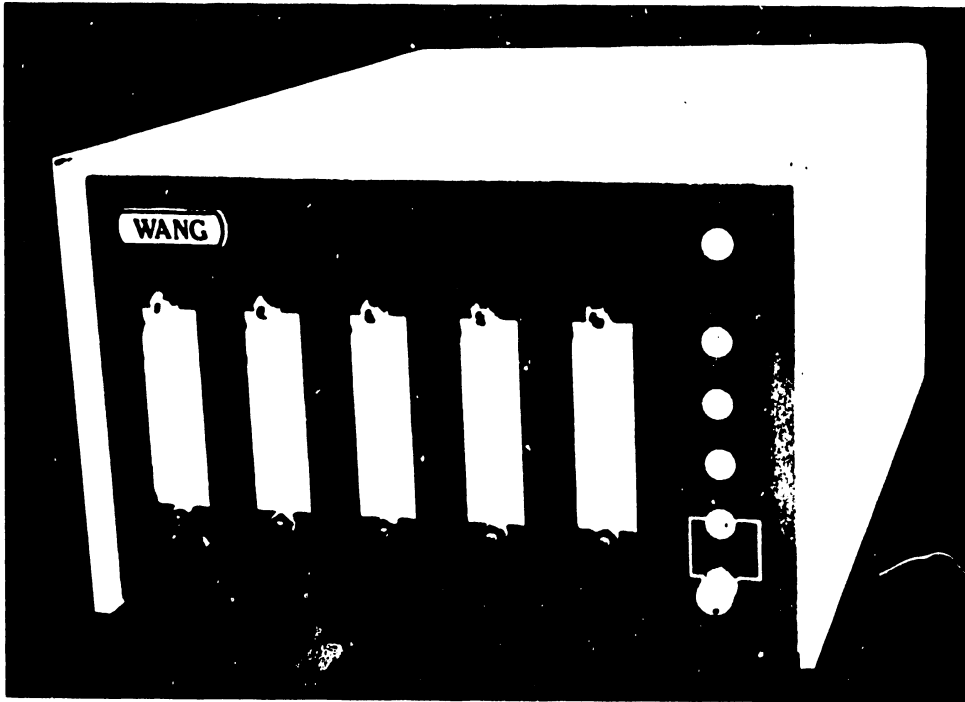

SECTION

1

**DESCRIP-
TION**

SECTION 1
DESCRIPTION

1.1 GENERAL

The Model 2211M Printer/Plotter Multiplexer is a modified version of the Model 2221M Printer/Plotter Multiplexer. The 2211M Multiplexer permits a single printer or plotter (except the Model 2212 and Model 2232A/B Flatbed Plotters) to be shared by up to four units: 2200A, B, C, S, T, VP, MVP [Central Processing Units (CPU's)]; 2200E [Portable Computing System (PCS)]; PCS2/2A; 2200F [Work Station (WS)]; and 2236D/DE Interactive Terminals.

NOTE:

Hereinafter, the units listed above will be referred to as "CP/WS", and "printer/plotter" will be represented by "P/P".

As of the date of this manual, Wang Laboratories does not sell the 2211M Multiplexer for the purpose of connecting it to a VS CPU; furthermore, the Home Office Customer Engineering Group does not support the VS/2211M configuration.

The 2211M Multiplexer is packaged in a chassis that contains the digital logic, channel indicators, channel-select switch, and power supply. Five 36-pin female connectors accept the P/P and CP/WS cables. Four 12-foot (3.7-meter) CP/WS interconnection cables are supplied with the multiplexer.

1.2 SPECIFICATIONS

Required Supply Voltage:

115 or 230 volts ($\pm 10\%$), ac, 50 or 60 hertz (± 1 hertz)

Power Consumption:

25 watts

Heat Output:

85 BTU/hr

Fuse Rating:

115 volts - 6/10 ampere, 250 volts, slow-blow (WL #360-1006SB)

230 volts - 3/10 ampere, 250 volts, slow-blow (WL #360-1003SB)

Cable Description:

Ac Power Cord - 6 ft (1.8 m)

CP/WS Inter-connection Cable - 12 ft (3.7 m) (WL #220-0105)

Operating Environment:

Temperature - 50^oF to 90^oF (10^oC to 32^oC)

Relative Humidity - 30% to 80%, non-condensing

Dimensions of Chassis:

Height - 5.5 in. (13.8 cm)

Width - 8 in. (20.0 cm)

Length - 11.5 in. (28.8 cm)

Weight - 15 lbs (6.7 kg)

SECTION

2

**UNPACKING &
INCOMING
INSPECTION**

SECTION 2
UNPACKING AND INCOMING INSPECTION

Before unpacking the unit, visually inspect the shipping container for any indications of shipping damage (crushed edges or corners, punctures, tears, etc.). If any shipping damage is found, file an appropriate claim with the carrier involved.

Open the shipping container and remove all packing material. Remove the unit from the shipping container and place the unit on a flat, sturdy surface. Once again visually inspect the unit for damage. If any shipping damage is found, file an appropriate claim with the carrier involved and notify the WL Distribution Center (Department 90), Quality Assurance Department, Tewksbury, MA. 01876, of the nature and extent of the damage, making arrangements for equipment replacement, if necessary.

Four 12-foot (3.7-meter) CP/WS interconnection cables should be included with the unit. Inspect each cable for damage.

SECTION

3

INITIAL

SETUP

SECTION 3
INITIAL SETUP

- A. Remove the six screws that secure the multiplexer cover to the chassis and then remove the cover of the unit. Inspect the unit for damaged assemblies, loose hardware and/or solder splashes.
- B. Ensure that the ac line voltage and frequency provided at the installation site is correct for the unit. (The line voltage and frequency at which the unit is set to operate is indicated on the unit serial number tag; refer to FIGURE 3-2.) Verify that the voltage-select switch (ref: FIGURE 3-3) is set properly. Verify that the multiplexer ac power ON/OFF switch is in the OFF position. The ac power cord may now be plugged in.
- C. Place the ac power switch (ref: FIGURE 3-2) to the ON position. The POWER indicator and the channel #1 (CH 1) indicator on the front panel should light.
- D. Check +5VR with a digital voltmeter (dvm). This may be done by placing the negative lead of the dvm on pin 7 of L1 and the positive lead on pin 14 of L1 (ref: FIGURE 3-4). Ensure voltage is between +4.8V and +5.2V. There is no +5VR adjustment.
- E. Place the multiplexer ac power switch to the OFF position.
- F. (Refer to FIGURE 3-1 and FIGURE 3-5.) Plug the I/O cable that is attached to the printer or plotter into the jack labeled "I/O". Using the CP/WS interconnection cables supplied (WL# 220-0105), connect the CP/WS designated #1 to the jack labeled "CH 1"; connect the #2 CP/WS to "CH 2", the #3 to "CH 3", and the #4 to "CH 4".
- G. Place the multiplexer ac power switch to the ON position and run all appropriate (printer or plotter) diagnostics on each system channel (ref: Diagnostic Testing Procedures, Section 5). After each channel has been tested, replace the cover of the unit.

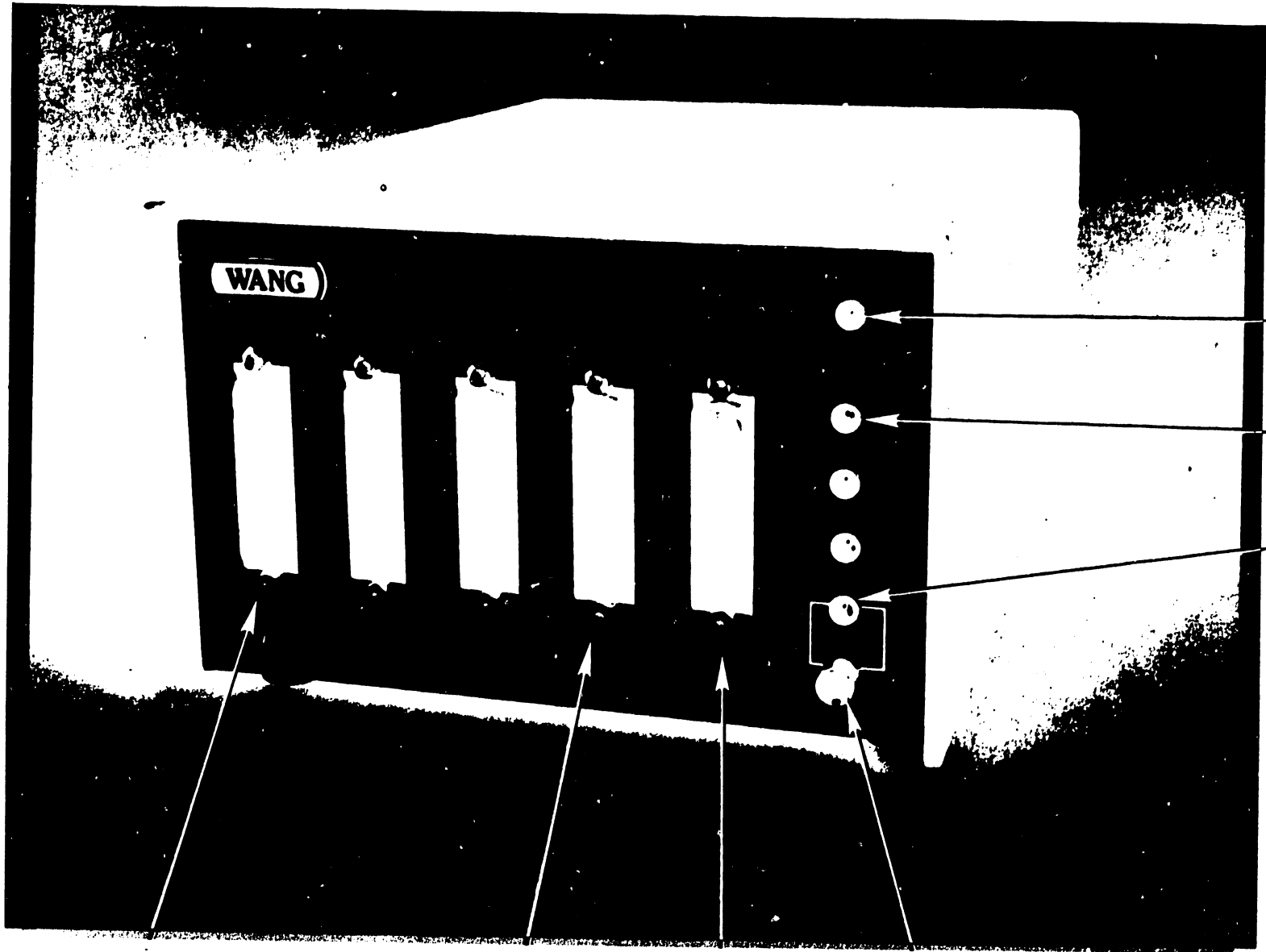

CHANNEL #1
(CPU #1)
JACK

CHANNEL #4
(CPU #4)
JACK

I/O
(PRINTER/
PLOTTER)
JACK

CHANNEL-
SELECT
SWITCH

POWER
INDICATOR

CHANNEL #1
INDICATOR

CHANNEL #4
INDICATOR

FIGURE 3-1 2211M; FRONT VIEW

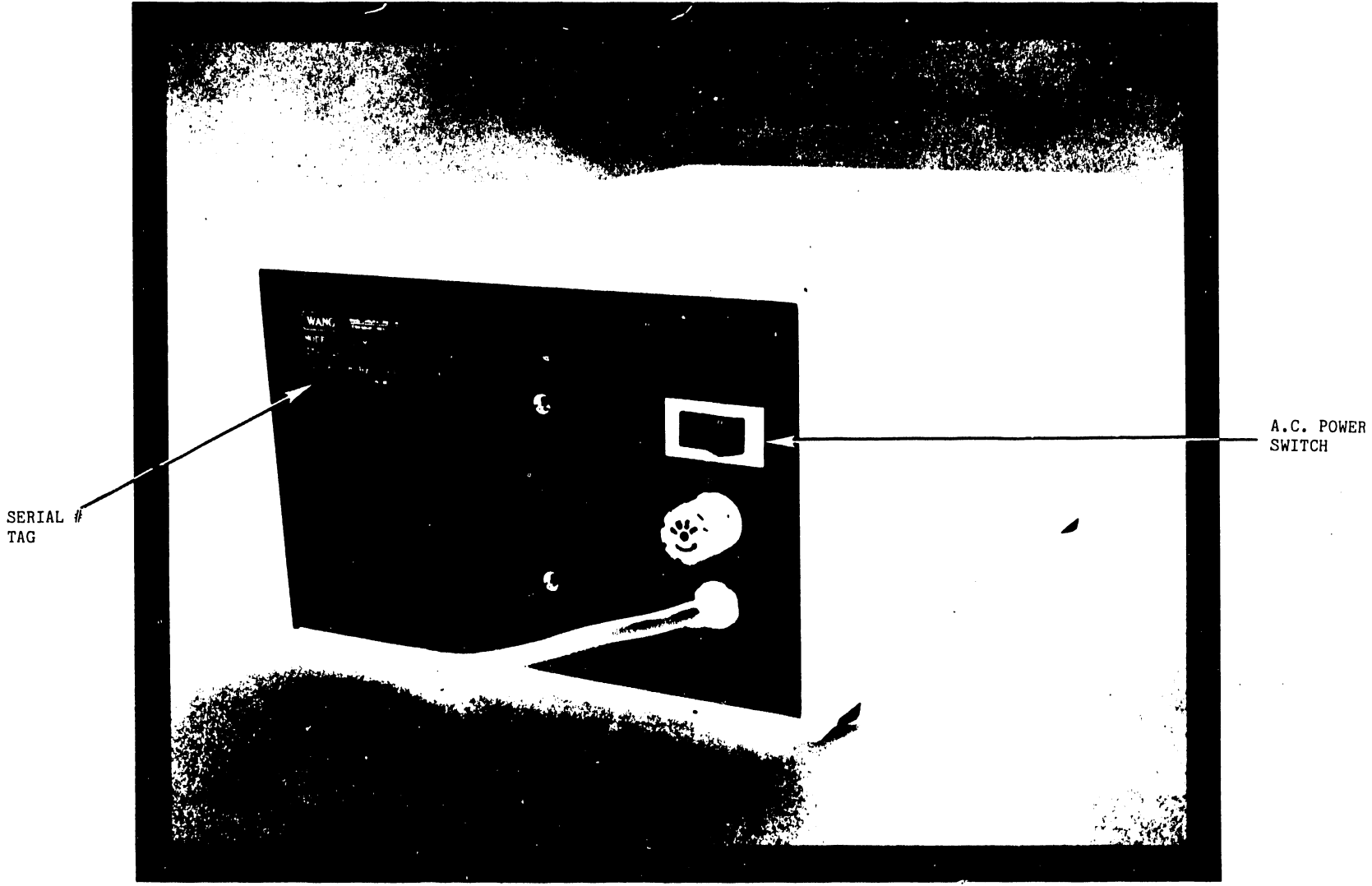

FIGURE 3-2 2211M; REAR VIEW

VOLTAGE-
SELECT
SWITCH

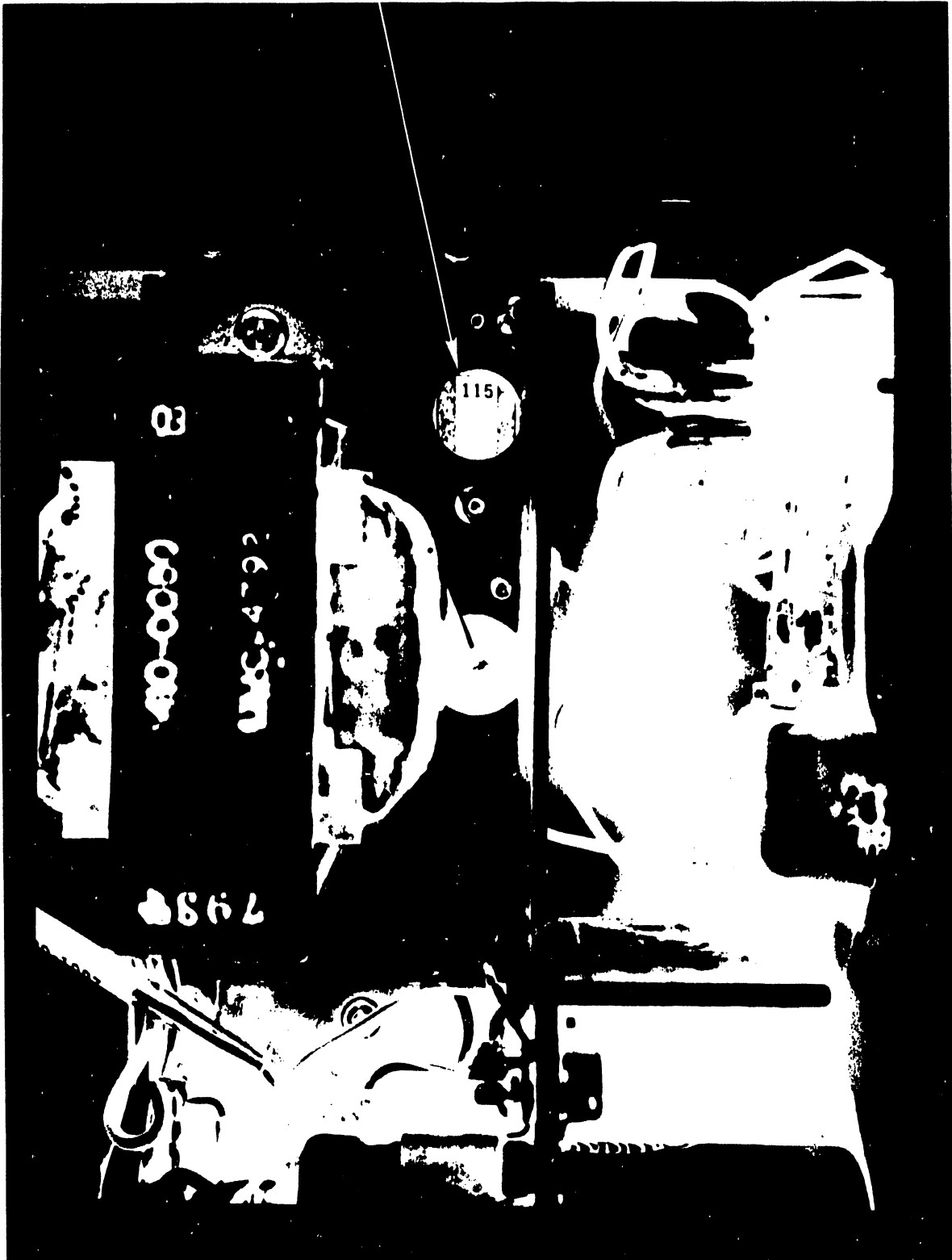
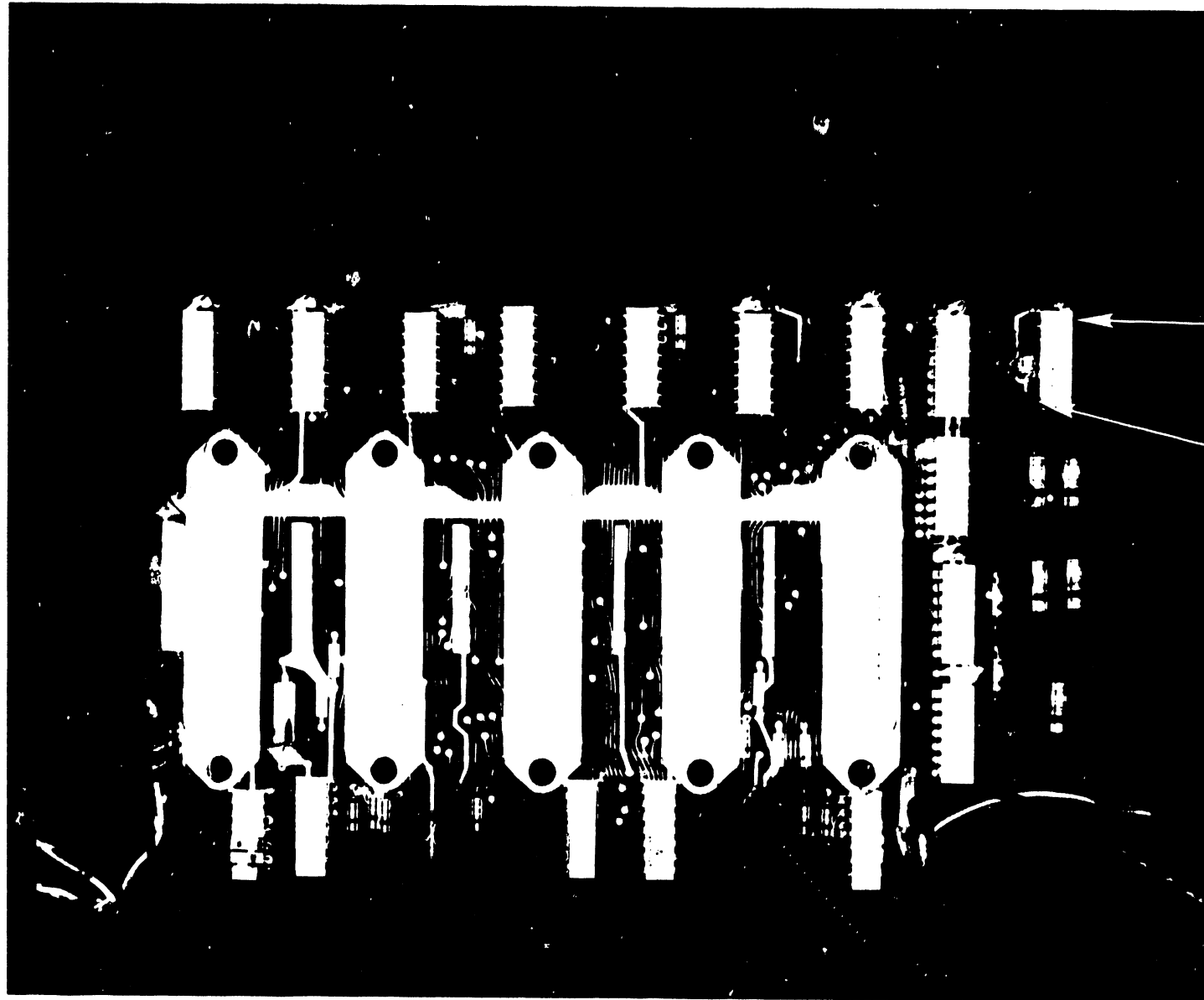

FIGURE 3-3 VOLTAGE-SELECT SWITCH



L1-14
+5VR
CHECK
POINTS
L1-7

FIGURE 3-4 210-7430 PCB; +5VR CHECK POINTS

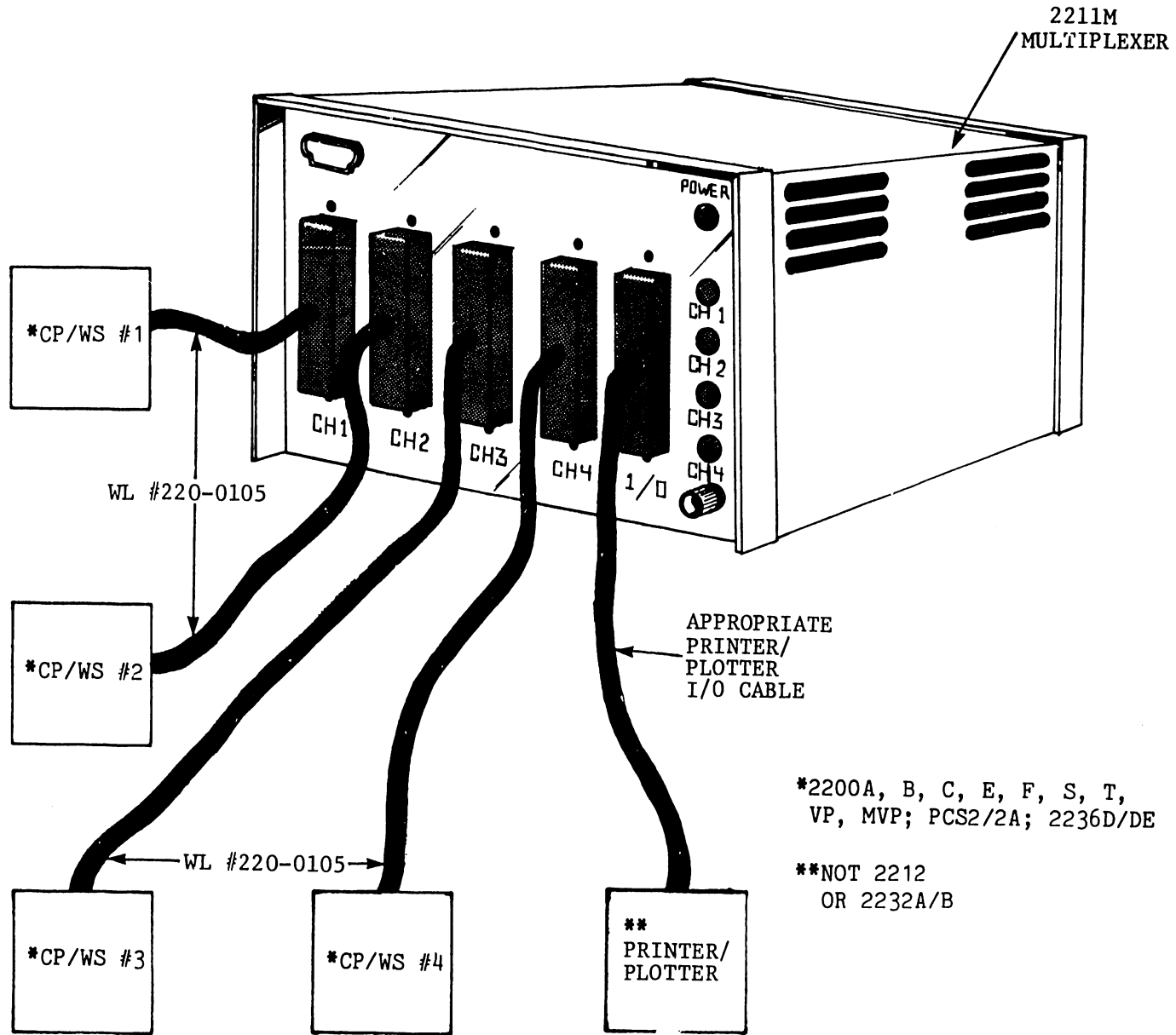

FIGURE 3-5 SYSTEM CONFIGURATION

SECTION

4

THEORY

OF

OPERA-

TIONS

SECTION 4
THEORY OF OPERATION (BLOCK LEVEL)

4.1 GENERAL

The 2211M Multiplexer controls access to the printer or plotter by means of select circuitry that is regulated by a channel-select switch. This manually operated switch determines which of the four possible CP/WS's will have exclusive access to the P/P. At power-on, the multiplexer automatically selects channel #1. Incorporated into the multiplexer electronics is a four-second channel-select delay that prevents inadvertent output from a bypassed channel while the desired channel is being selected.

4.2 POWER-ON (Reference FIGURE 4-1.)

Power-on sets the channel-selection counter (L3), which is made up of two 7473-type flip/flops wired to count from '0' to '3' in binary, to the 'clear' state (00_2). This action lights the CH 1 indicator, and channel #1 is selected for printer access. (See following Channel Selection theory.)

4.3 CHANNEL-SELECTION (Reference FIGURE 4-1.)

When the channel-select switch is depressed, the select flip/flop (L13) 'sets', and then 'resets' when the switch is released. The pulse provided by the select flip/flop output (pin 6) clocks the channel-selection counter. A count of '1' causes the LED decoder (L2) to illuminate the CH 2 indicator. At the same time, the outputs from the channel-selection counter allow the eight data bits, the data strobe bit, and the prime bit from CP/WS #2 to pass through multiplexers (L4,7,8,9,15) to the printer. The channel-selection counter outputs also allow the P/P status bits to pass through de-multiplexers (L5,6,16) to CP/WS #2.

Operation for other CP/WS channels is similar to that described above-- with a channel-selection counter output of 00_2 selecting channel #1, 10_2 selecting channel #3, and 11_2 , channel #4.

4.4 PROTECT-DELAY (Reference FIGURE 4-1.)

When the channel-select switch is depressed, the protect-delay circuitry (L17, 18) produces a 4-second pulse. This pulse disables all multiplexer and de-multiplexer outputs for that 4-second protect interval. This design feature ensures no inadvertent output from a bypassed channel while the desired channel is being selected. Four seconds after the desired channel is selected, the 2211M Multiplexer will enable the data and status lines to the P/P.

4.5 SIGNAL MNEMONICS

| | |
|--------------------------|---|
| $\overline{\text{ACK}}$ | Acknowledge from P/P; buffered acknowledge to CP/WS |
| BUSY | Busy status from P/P; buffered busy status to CP/WS |
| CLK | Clock from P/P; buffered clock to CP/WS |
| D1 - D8 | Data lines from CP/WS; buffered data lines to P/P |
| $\overline{\text{DSTB}}$ | Data strobe from CP/WS; buffered data strobe to P/P |
| FAULT | Fault status from P/P |
| FAULT ₁₋₄ | Fault status to CP/WS |
| PO | Paper out status from P/P; buffered paper out status to CP/WS |
| PRIME | Prime line from CP/WS; buffered prime line to P/P |
| SL | Select line from CP/WS; buffered select line to P/P |

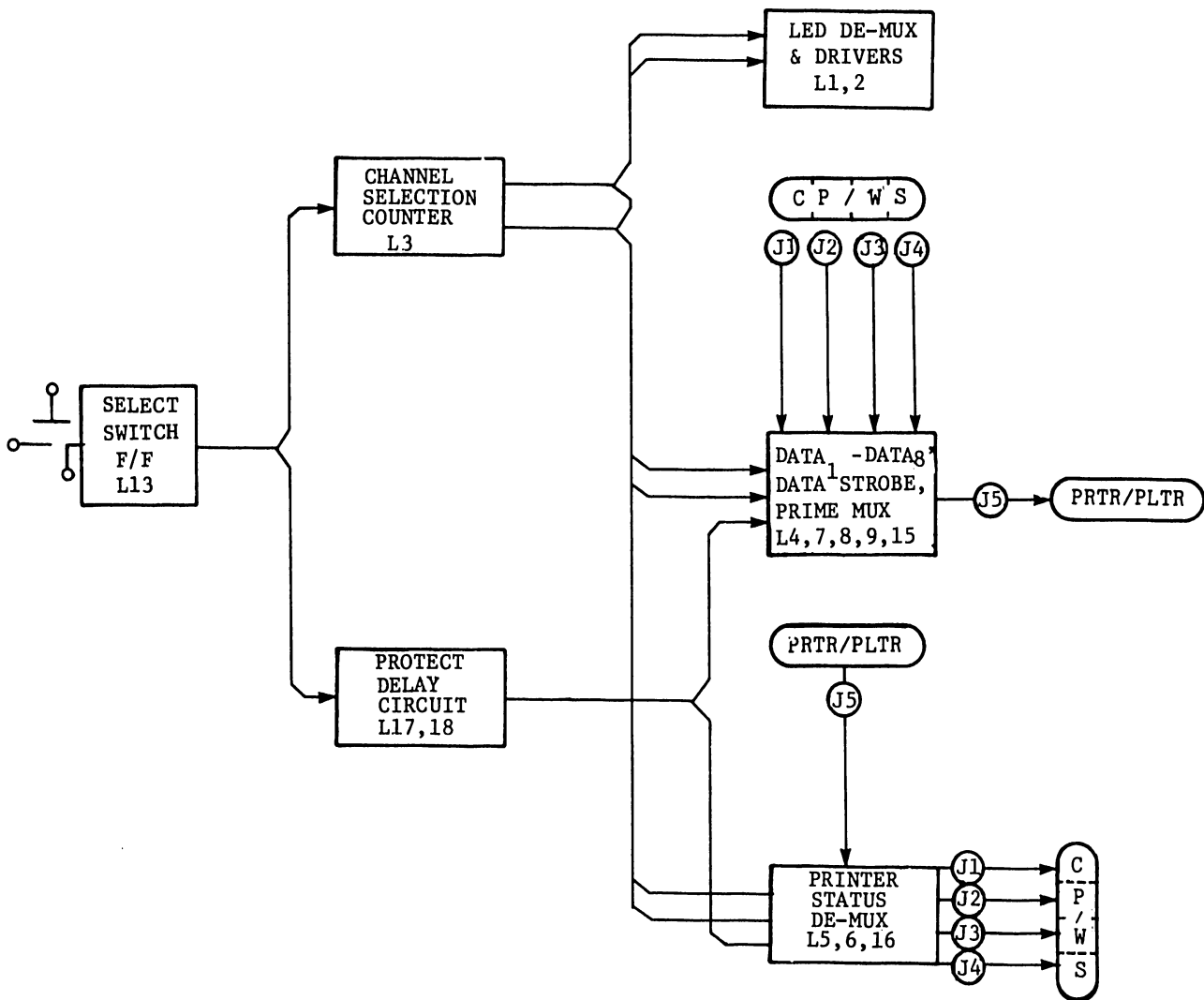

FIGURE 4-1 BLOCK DIAGRAM

SECTION

5

**DIAGNOSTIC
TESTING
PROCEDURES**

SECTION 5

DIAGNOSTIC TESTING PROCEDURES

5.1 PRELIMINARY CHECK

After power is applied and channel #1 is selected, depress the channel-select switch and the CH 2 LED should light. Depress the channel-select switch a second time; the CH 3 LED should light. Depress the channel-select switch once more; the CH 4 LED should light. Depressing the channel-select switch one final time should cause the CH 1 LED to relight, thus completing the channel-select count-sequence/cycle.

5.2 PRINTER/PLOTTER DIAGNOSTIC

A standard 2200 printer or plotter diagnostic should be run on each system channel. Reference the appropriate CP/WS manual(s) for P/P diagnostic operating procedures.

The P/P diagnostic may be run on all four system channels simultaneously. Programs in the CP/WS's that are not selected by the 2211M Multiplexer will "hang-up" when they attempt to access the P/P. When a waiting ("hung") unit is selected, the selected unit will transfer data to the P/P. (Index the channel-select switch as required.) The multiplexer will not allow CP/WS-to-P/P data transfer until four seconds have elapsed from the time the channel-select switch is depressed, thus enabling a given channel. If the channel-select switch is depressed while the P/P is operating, the output will immediately be interrupted (data may be lost), and four seconds later the new channel will transfer data to the P/P. The CP/WS that was utilizing the P/P will not display an error message; that CP/WS will "hang", attempting to access the P/P. When the interrupted channel is re-selected, that CP/WS regains access to the P/P, and transfers the next line of data to the P/P.

SECTION

6

**TROUBLE-
SHOOTING**

SECTION 6
TROUBLESHOOTING

The Single-Board Printer Exerciser (WL #190-0704) may be attached to each 2211M Multiplexer CP/WS jack to aid in troubleshooting a defective system.

SECTION

7

**BILL OF
MATER-
IALS**

SECTION 7
BILL OF MATERIALS

The 2211M Multiplexer Bill of Materials starts on the next page. At the end of this section (page 7-8), there is a photograph of the interior of the unit with all major assemblies and components pointed out.

MB0080-A MULTI-LEVEL BILL OF MATERIAL

ASSEMBLY PART NUMBER 177-2211-M - -
 ASSEMBLY DESCRIPTION 2211M PRINTER MULTIPLEXER

LEGEND
 1: P=PHANTOM; 2: ITEM MASTER DELY CODE

III.C.O.M-0

| POSITION IN STRUCTURE | LEGEND | | | COMPONENT PART NUMBER | DESCRIPTION | E C N | QUANTITY PER ASSY | U/M |
|-----------------------|--------|------|---|-----------------------|---------------------------------------|------------------|-------------------|------|
| | 1 | 2 | 3 | | | | | |
| 1 | | IN | | 187-2211-M - - | 2211M PRINTER MULTIPLEXER | | 1.0000 | EACH |
| 2 | | IN | | 000-0005- - - | LABOR PRODUCTION SYSTEMS | | 2.6360 | |
| 2 | | IN | | 000-0011- - - | LABOR QUALITY CONTROL | | .5270 | |
| 2 | | IN | * | 210-7430- - - | PCA 2291 PRINTER MULTIPLEXER | | 1.0000 | EACH |
| 3 | | IN | | 000-0001- - - | LABOR CIRCUIT SYSTEMS | | 2.6420 | |
| 3 | | IN | | 000-0011- - - | LABOR QUALITY CONTROL | | .5280 | |
| 3 | | IN | | 000-6011- - - | CIRCUIT SYS.-ASSY. | | 2.6420 | EACH |
| 3 | | IN | | 220-1294- - - | POWER CABLE 2211M | B6482-203 E11240 | 1.0000 | EACH |
| 4 | | IN | | 000-0004- - - | LABOR SUB-SYSTEMS | | .2500 | EACH |
| 4 | | IN | | 000-0011- - - | LABOR QUALITY CONTROL | | .0500 | |
| 4 | | IN | | 000-6043- - - | SUB-SYS.-CABLES | | .2500 | EACH |
| 4 | | P FS | | 600-1000- - - | WIRE 22 GA BLACK | | .4600 | FEET |
| 5 | | FS | | 600-1009- - - | WIRE 22 GA WHITE | | 1.0000 | FEET |
| 4 | | P FS | | 600-1002- - - | WIRE 22 GA RED | | .4600 | FEET |
| 5 | | FS | | 600-1009- - - | WIRE 22 GA WHITE | | 1.0000 | FEET |
| 4 | | FS | | 605-0014- - - | TUBING #5 CLEAR | | .2900 | FEET |
| 4 | | IN | | 606-1294- - - | 3/8" DIA WHT SHRINK BLK NU 220-1294 | E11840 | 1.0000 | EACH |
| 4 | | IN | | 654-1147- - - | PIN HOUSING 1-480319-0 | | 1.0000 | EACH |
| 4 | | FS | | 654-1166-R - - | PIN TERM 30-22 GA (REEL) AMP3500079-4 | | 2.0000 | EACH |
| 3 | | IN | | 220-1295- - - | POWER CABLE TO BD | B6482-460 E11240 | 1.0000 | EACH |
| 4 | | IN | | 000-0004- - - | LABOR SUB-SYSTEMS | | .1600 | EACH |
| 4 | | IN | | 000-0011- - - | LABOR QUALITY CONTROL | | .0320 | |
| 4 | | IN | | 000-6043- - - | SUB-SYS.-CABLES | | .1600 | EACH |
| 4 | | P FS | | 600-2000- - - | WIRE 24 GA BLACK UL | | .2500 | FEET |
| 5 | | FS | | 600-2009- - - | WIRE 24 GA WHITE UL | | 1.0000 | FEET |
| 4 | | P FS | | 600-2004- - - | WIRE 24 GA YELLOW UL | | .2500 | FEET |
| 5 | | FS | | 600-2009- - - | WIRE 24 GA WHITE UL | | 1.0000 | FEET |

7-2

| | | | | | | | | |
|---|---|------|------------|-----|--------------------------------------|------------------|---------|------|
| 4 | P | FS | 600-2005- | - - | WIRE 24 GA GREEN UL | W/OFF-76 | .2500 | FEET |
| 5 | | FS | 600-2009- | - - | WIRE 24 GA WHITE UL | | 1.0000 | FEET |
| 4 | | IN | 654-1149- | - - | PIN HOUSING 1-480305-0 | | 1.0000 | EACH |
| 4 | | FS | 654-1166-R | - - | PIN TERM 30-22 GA(REEL)AMP3500079-4 | | 3.0000 | EACH |
| 2 | | IN | 220-0105- | - - | 2221 PRINTER CABLE C6422-129 | E12925 | 4.0000 | EACH |
| 3 | | IN | 000-0004- | - - | LABOR SUB-SYSTEMS | | .7290 | EACH |
| 3 | | IN | 000-0011- | - - | LABOR QUALITY CONTROL | | .1460 | |
| 3 | | IN | 000-6043- | - - | SUB-SYS.-CABLES | | .5000 | EACH |
| 3 | | IN | 350-2082- | - - | CONN 18-36 CABLE TO PANEL PLUG | EC6407 | 2.0000 | EACH |
| 3 | | IN | 350-4233-G | - - | STRAIN RELIEF CVR 36 POS 180DEG GRV | EC8484 | 2.0000 | EACH |
| 3 | | IN | 350-4233-T | - - | STRAIN RELIEF CVR 36 POS 180DEG TNG | EC8484 | 2.0000 | EACH |
| 3 | | IN | 350-4234- | - - | 4-40X3/8 CAPT SCR FOR SCR MT CONNS. | EC6407 | 4.0000 | EACH |
| 3 | | FS | 420-0058- | - - | 18 TWISTED PAIR 26 GA SHIELDED CABLE | EC6407 | 13.0000 | FEET |
| 3 | | IN | 458-0361- | - - | GROUND STRAP C6815-28 | EC6407 | 2.0000 | EACH |
| 3 | | FS | 606-0105- | - - | CBL MARKER WH/BK 2221 220-0105 | EC9699 | 1.0000 | EACH |
| 4 | | FS | 605-0139- | - - | TUBING 1/2 WH SHRINK POLYOLEFIN | | .1140 | FEET |
| 3 | | IN | 615-1297- | - - | LABEL PRINTER CABLE CONN A53001072 | EC5402 | 2.0000 | EACH |
| 2 | | IN * | 270-0316- | - - | 2211M CHASSIS ASSY | | 1.0000 | EACH |
| 3 | | IN | 000-0004- | - - | LABOR SUB-SYSTEMS | | 1.1500 | EACH |
| 3 | | IN | 000-0011- | - - | LABOR QUALITY CONTROL | | .2300 | |
| 3 | | IN | 000-6041- | - - | SUB-SYS.-CHASSIS | | 1.1500 | EACH |
| 3 | | IN | 220-1296- | - - | POWER CABLE SWITCH | B6482-461 E11240 | 1.0000 | EACH |
| 4 | | IN | 000-0004- | - - | LABOR SUB-SYSTEMS | | .0200 | EACH |
| 4 | | IN | 000-0011- | - - | LABOR QUALITY CONTROL | | .0040 | |
| 4 | | IN | 000-6043- | - - | SUB-SYS.-CABLES | | .0200 | EACH |
| 4 | P | FS | 600-2000- | - - | WIRE 24 GA BLACK UL | | .2500 | FEET |
| 5 | | FS | 600-2009- | - - | WIRE 24 GA WHITE UL | | 1.0000 | FEET |
| 4 | P | FS | 600-2004- | - - | WIRE 24 GA YELLOW UL | | .2500 | FEET |
| 5 | | FS | 600-2009- | - - | WIRE 24 GA WHITE UL | | 1.0000 | FEET |

| | | | | | | | | |
|---|---|----|------------|-----|-------------------------------------|------------------|--------|------|
| 4 | P | FS | 600-2005- | - - | WIRE 24 GA GREEN UL | W/OFF-76 | .2500 | FEET |
| 5 | | FS | 600-2009- | - - | WIRE 24 GA WHITE UL | | 1.0000 | FEET |
| 4 | | IN | 654-1150- | - - | SOCKET HOUSING 1-480303-0 | | 1.0000 | EACH |
| 4 | | FS | 654-1165-R | - - | SOCKET 30-22 GA (REEL) AMP 350078-4 | | 3.0000 | EACH |
| 3 | P | IN | 270-0584- | - - | 2224/2211M MULTI PWR SUPPLY ASSY | E11739 | 1.0000 | EACH |
| 4 | | IN | 000-0004- | - - | LABOR SUB-SYSTEMS | | 2.0000 | EACH |
| 4 | | IN | 000-0011- | - - | LABOR QUALITY CONTROL | | .4000 | |
| 4 | | IN | 210-6281- | - - | 6281 MODULE | W/OFF/79 | 1.0000 | EACH |
| 5 | | IN | 000-0001- | - - | LABOR CIRCUIT SYSTEMS | | .0900 | |
| 5 | | IN | 000-0011- | - - | LABOR QUALITY CONTROL | | .0180 | |
| 5 | | IN | 000-6011- | - - | CIRCUIT SYS.-ASSY. | | .0900 | EACH |
| 5 | | IN | 300-1901- | - - | CAP .1 UF 20% 12 V CERAMIC DISC | | 1.0000 | EACH |
| 5 | | IN | 300-1902- | - - | .22 UF 20% CERAMIC CAP. | | 1.0000 | EACH |
| 5 | | IN | 331-0027- | - - | RES 2.7 OHM 1/2W 10% FIXED COMP | | 1.0000 | EACH |
| 6 | | FS | 331-0027-R | - - | RES 2.7 OHM 1/2W 10% FIXD COMP T&R | | 1.0000 | EACH |
| 5 | | IN | 510-6281- | - - | 6281 PRINTED CIRCUIT BOARD | | 1.0000 | EACH |
| 4 | | IN | 220-1349- | - - | PCS II 12 VOLT CABLE | B6482-157 E13074 | 1.0000 | EACH |
| 5 | | IN | 000-0004- | - - | LABOR SUB-SYSTEMS | | .0930 | EACH |
| 5 | | IN | 000-0011- | - - | LABOR QUALITY CONTROL | | .0190 | |
| 5 | | IN | 000-6043- | - - | SUB-SYS.-CABLES | | .0930 | EACH |
| 5 | P | FS | 600-1000- | - - | WIRE 22 GA BLACK | | .3300 | FEET |
| 6 | | FS | 600-1009- | - - | WIRE 22 GA WHITE | | 1.0000 | FEET |
| 5 | P | FS | 600-1002- | - - | WIRE 22 GA RED | | .3300 | FEET |
| 6 | | FS | 600-1009- | - - | WIRE 22 GA WHITE | | 1.0000 | FEET |
| 5 | | FS | 605-0014- | - - | TUBING #5 CLEAR | | .2200 | FEET |
| 5 | | IN | 654-1148- | - - | SOCKET HOUSING 1-480318-0 | | 1.0000 | EACH |
| 5 | | FS | 654-1165-R | - - | SOCKET 30-22 GA (REEL) AMP 350078-4 | | 2.0000 | EACH |
| 4 | | IN | 300-3075- | - - | 14K UF 12V ELECT.CAP(SCREW TYPE) | | 1.0000 | EACH |
| 4 | | IN | 300-9009- | - - | CAP CLAMP 1 1/4 INCH 2 LUG CMC-22 | | 1.0000 | EACH |
| 4 | | IN | 310-0005- | - - | 5 TERMINAL STRIP | | 1.0000 | EACH |
| 4 | | IN | 325-2112- | - - | SLIDE SW.115/230 VAC | | 1.0000 | EACH |
| 4 | | IN | 331-4010- | - - | RES 10K OHM 1/2W 10% FIXED COMP | | 1.0000 | EACH |
| 5 | | FS | 331-4010-R | - - | RES 10K OHM 1/2W 10% FIXD COMP T&R | | 1.0000 | EACH |
| 4 | | IN | 374-0001- | - - | IC REG UA 7805 +5V TO-220 | | 1.0000 | EACH |

| | | | | | | |
|---|------|-----------|-----|-------------------------------------|--------|------|
| 4 | IN | 375-1030- | - - | 2N5956 TRANSISTOR | 1.0000 | EACH |
| 4 | IN | 375-9015- | - - | INSULATOR XTOR MOUNT WECKESSER TM-2 | 1.0000 | EACH |
| 4 | IN | 375-9019- | - - | MICA WSHR (SMALL) FOR POWER X1STORS | 1.0000 | EACH |
| 4 | IN | 380-3002- | - - | DIO 1N4719 50V 3A RECT S C60 | 2.0000 | EACH |
| 4 | IN | 410-0080- | - - | MMC 4792 TRANSFORMER (723/724) | 1.0000 | EACH |
| 4 | IN | 451-4186- | - - | 723/724 PWR SUPPLY BRKT C6466-29 | 1.0000 | EACH |
| 4 | IN | 510-6749- | - - | 6749 PRINTED CIRCUIT BOARD | 1.0000 | EACH |
| 4 | P FS | 600-0094- | - - | 18 GA WIRE WH/YELLOW | .2920 | FEET |
| 5 | FS | 600-0009- | - - | WIRE 18 GA WHITE UL | 1.0000 | FEET |
| 4 | P FS | 600-2000- | - - | WIRE 24 GA BLACK UL | .5000 | FEET |
| 5 | FS | 600-2009- | - - | WIRE 24 GA WHITE UL | 1.0000 | FEET |
| 4 | P FS | 600-2001- | - - | WIRE 24 GA BROWN UL | .2500 | FEET |
| 5 | FS | 600-2009- | - - | WIRE 24 GA WHITE UL | 1.0000 | FEET |
| 4 | P FS | 600-2002- | - - | WIRE 24 GA RED UL | .6200 | FEET |
| 5 | FS | 600-2009- | - - | WIRE 24 GA WHITE UL | 1.0000 | FEET |
| 4 | P FS | 600-2091- | - - | WIRE 24 GA WH/BRN UL | .2500 | FEET |
| 5 | FS | 600-2009- | - - | WIRE 24 GA WHITE UL | 1.0000 | FEET |
| 4 | P FS | 600-2094- | - - | WIRE 24 GA WH/YEL UL | .5420 | FEET |
| 5 | FS | 600-2009- | - - | WIRE 24 GA WHITE UL | 1.0000 | FEET |
| 4 | IN | 650-2087- | - - | 4-40X1/4 PAN HD PHL MS SS MAG. SEMS | 2.0000 | EACH |
| 4 | IN | 650-2120- | - - | 4-40 X 3/8 PAN HD PHL MS SS SEMS | 2.0000 | EACH |
| 4 | IN | 650-3131- | - - | 6-32 X 3/8 NYLON COVERED FIL HD SLT | 1.0000 | EACH |
| 4 | IN | 650-3160- | - - | 6-32 X 1/2 PAN HD PHL MS SS SEMS | 3.0000 | EACH |
| 4 | IN | 650-4120- | - - | 8-32 X 3/8 PAN HD PHL MS SS SEMS | 2.0000 | EACH |
| 4 | IN | 651-0405- | - - | 3/16 X 3/8 POP RIVET | 2.0000 | EACH |
| 4 | IN | 652-2005- | - - | 4-40 LOCK-NUT KEPS SS | 2.0000 | EACH |
| 4 | IN | 652-3004- | - - | NUT 6-32UNC HEX SMALL PAT SS | 3.0000 | EACH |
| 4 | IN | 653-2000- | - - | NO. 4 FLAT WASHER | 2.0000 | EACH |
| 4 | IN | 653-3000- | - - | WASH 6 .149ID .3750D .016 FL SS | 2.0000 | EACH |
| 4 | IN | 653-3001- | - - | WASH 6 .150ID .2880D INT T ST | 2.0000 | EACH |
| 4 | IN | 654-1006- | - - | #6 GROUND LUG | 1.0000 | EACH |
| 4 | IN | 654-1010- | - - | #10 GROUND LUG | 2.0000 | EACH |
| 4 | IN | 654-1201- | - - | GROMMET 1/4 ID FOR 3/8 HOLE | 1.0000 | EACH |

7-6

| | | | | | | | |
|---|------|-----------|-----|-------------------------------------|-----------|--------|------|
| 3 | IN | 279-0300- | - - | MICRO SWITCH ASSY.C6060-203 | E11240 | 1.0000 | EACH |
| 4 | IN | 000-0011- | - - | LABOR QUALITY CONTROL | | .0040 | |
| 4 | IN | 000-0024- | - - | LABOR PREP AREA | | .0180 | EACH |
| 4 | IN | 279-0301- | - - | PLUNGER GUIDE ASSEMBLY 6815-51 | EC6269 | 1.0000 | EACH |
| 5 | IN | 000-0011- | - - | LABOR QUALITY CONTROL | | .0010 | |
| 5 | IN | 000-0024- | - - | LABOR PREP AREA | | .0050 | EACH |
| 5 | IN | 451-4066- | - - | 301 MICRO-SW BRACKET C5933-116 | (2 | 1.0000 | EACH |
| 5 | IN | 478-0068- | - - | 301 PLUNGER GUIDE B5933-117 | (2 | 1.0000 | EACH |
| 4 | IN | 325-2305- | - - | 11SM1 MICRO SWITCH FOR CP-1 | | 1.0000 | EACH |
| 4 | IN | 461-3056- | - - | 301 SWITCH PLUNGER B5933-114 | | 1.0000 | EACH |
| 4 | IN | 651-0416- | - - | 301 RIVET B5933-130 | | 2.0000 | EACH |
| 3 | IN | 325-0021- | - - | SWITCH, ROCKER SPST | | 1.0000 | EACH |
| 3 | IN | 325-9035- | - - | PUSH BUTTON BLACK ALCO #C12 | E11681 | 1.0000 | EACH |
| 3 | IN | 360-0000- | - - | FUSE HOLDER 90 DEGREE CONTACT | | 1.0000 | EACH |
| 3 | IN | 360-9000- | - - | RUBBER WSHR FOR 360-0000 / 360-0001 | | 1.0000 | EACH |
| 3 | IN | 360-9002- | - - | HEX NUT FOR 360-0000 / 360-0001 | | 1.0000 | EACH |
| 3 | IN | 360-9003- | - - | LOCK WSHR LF#905023(FOR 360-0000/1) | | 1.0000 | EACH |
| 3 | IN | 370-1055- | - - | LAMP HOLDER 2 PIECE FOR 370-0026 | E12543 | 1.0000 | EACH |
| 3 | IN | 370-1056- | - - | LAMP HOLDER 2 PIECE FOR 370-0027 | E12543 | 4.0000 | EACH |
| 3 | IN | 410-2001- | - - | LINE FILTER,2 AMP 2B2 | | 1.0000 | EACH |
| 3 | IN | 420-1096- | - - | POWER CORD,10 FT 18AWG | E11240 | 1.0000 | EACH |
| 3 | IN | 451-1128- | - - | CHASSIS,FAB | 6618-1 | 1.0000 | EACH |
| 3 | P FS | 600-0000- | - - | WIRE 18 GA BLACK UL | E11681 | .6670 | FEET |
| 3 | FS | 605-0010- | - - | TUBING PVC #8 CLEAR | E11681 | .3120 | FEET |
| 3 | FS | 605-0014- | - - | TUBING #5 CLEAR | E11681 | .0620 | FEET |
| 3 | FS | 605-1004- | - - | CABLE TYE, PAN-TY PLTIM-M | E11681 | 1.0000 | EACH |
| 3 | IN | 650-3120- | - - | 6-32 X 3/8 PAN HD PHL MS SS SEMS | | 4.0000 | EACH |
| 3 | IN | 651-0405- | - - | 3/16 X 3/8 POP RIVET | | 4.0000 | EACH |
| 3 | IN | 652-0003- | - - | 1/4-40 HEX NUT | E11240 | 1.0000 | EACH |
| 3 | IN | 652-0032- | - - | 6-32 LOCK-NUT KEPS 511-061800-00 | E11802 | 2.0000 | EACH |
| 3 | IN | 652-0061- | - - | DRESS NUT 1/4-20 CHROME C&K A7099 | E11240 | 1.0000 | EACH |
| 3 | IN | 652-3004- | - - | NUT 6-32UNC HEX SMALL PAT | SS E11240 | 1.0000 | EACH |
| 3 | IN | 653-3000- | - - | WASH 6 .149ID .3750D .016 FL | SS E11681 | 1.0000 | EACH |
| 3 | IN | 653-3003- | - - | WASH 6 .141ID .2530D SPLIT | SS E11240 | 1.0000 | EACH |
| 3 | IN | 653-6009- | - - | WASH 1/4 .267ID .4780D INT T | ST E11962 | 1.0000 | EACH |
| 3 | IN | 654-1006- | - - | #6 GROUND LUG | | 1.0000 | EACH |
| 3 | IN | 654-1238- | - - | HEYCO STRAIN RELIEF SR5P-4 | | 1.0000 | EACH |
| 3 | IN | 655-0202- | - - | FEET WH LG WITH WSHR REC 2084 W | | 4.0000 | EACH |

| | | | | | | | |
|---|----|----------------|---------------------------|--------------------------|------------|---------|------|
| 2 | IN | 360-1006-SB- - | FUSE | 6/10 AMP 250V SB GLASS | 3AG E11763 | 1.0000 | EACH |
| 2 | IN | 450-0904- - - | WANG NAME TAG | C6815-97 | | 1.0000 | EACH |
| 2 | IN | 451-2049- - - | 703 COVER ASSY | D6100-6 | | 1.0000 | EACH |
| 2 | IN | 462-0411- - - | SPACFR PTR MLTPLXR | B6647-110 | | 10.0000 | EACH |
| 2 | IN | 615-1073- - - | UNIVERSAL ID LABEL(LARGE) | C5300-1066 | | 1.0000 | EACH |
| 2 | IN | 650-3125- - - | 6-32X3/8 FL HD PHL MS | PARKERIZE | | 6.0000 | EACH |
| 2 | IN | 652-6000- - - | NUT | 10-32UNC HEX REG PAT | SS | 10.0000 | EACH |
| 2 | IN | 653-0001- - - | WASH | 19 .196ID .3750D .062 FL | NYL | 10.0000 | EACH |

7-8

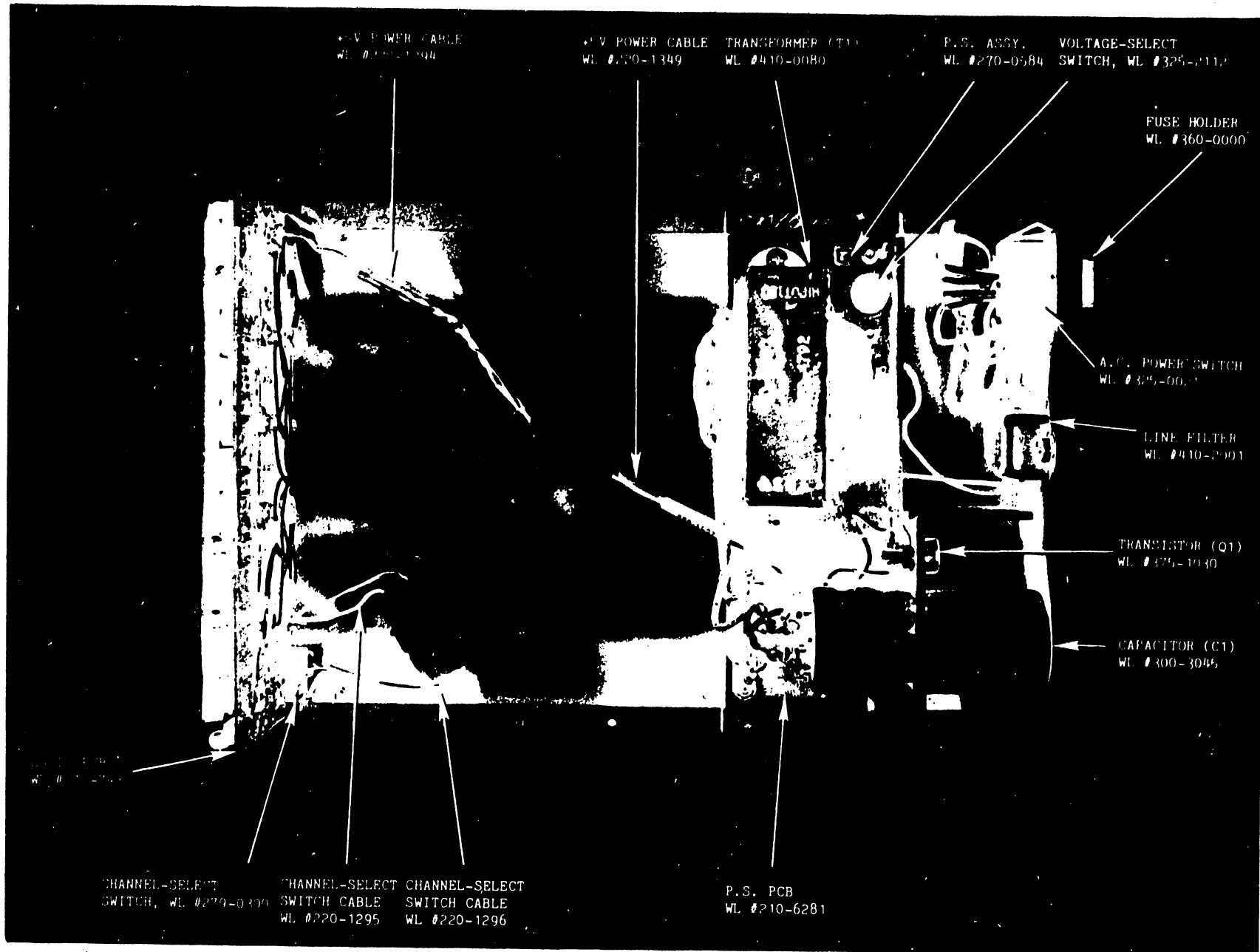

FIGURE 7-1 MAJOR ASSEMBLIES & COMPONENTS

SECTION

8

SCHE-

MATICS

SECTION 8
SCHEMATICS

The following schematics are contained in this section:

| <u>Description</u> | <u>Drawing #</u> |
|----------------------|------------------|
| 2211M Power Supply | C6281-1 |
| 210-7430 Electronics | D7430 |

THIS DOCUMENT IS THE PROPERTY OF WANG LABORATORIES, INC. AND SHALL NOT BE PRODUCED OR COPIED, OR USED AS A BASIS FOR THE MANUFACTURE OR SALE OF ANY TUBES OR DEVICES WITHOUT PERMISSION.

| HOLE LEGEND | | |
|--------------|---------------|-------|
| DRAILED OR | HOLE DIA. | TOL. |
| PUNCHED HOLE | .0425 to .125 | ±.002 |
| TOLERANCES: | .126 to .250 | ±.002 |
| | .251 to .500 | ±.002 |
| IDENT. | DESCRIPTION | QTY. |
| A | | |

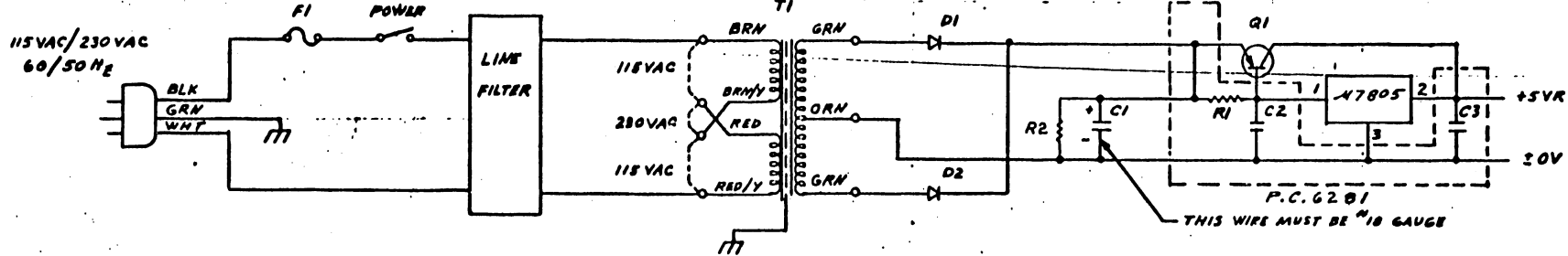

TOP VIEW

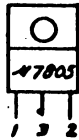

| COMP | SIZE/TYPE | W.L. | PART NO | QTY |
|-------------|------------|----------|---------|-----|
| R1 | 2.7Ω 1/2W | 331-0027 | 1 | |
| C1 | 10K MF 15V | 300-3045 | REF | |
| C2 | .22 MF CER | 300-1902 | 1 | |
| C3 | .1 MF CER | 300-1901 | 1 | |
| D1, 2 | 1N4719 | 380-3002 | REF | |
| Q1 | 40831 | 375-1030 | REF | |
| T1 | MMC472 | 410-0080 | REF | |
| | 47805 | 374-0001 | REF | |
| F1 | .6A | 360-1006 | REF | |
| LINE FILTER | 2AMP | 910-2001 | REF | |
| R2 | 10K 1/2W | 331-4010 | REF | |

| REVISION | DATE | BY | DESCRIPTION |
|----------|----------|----|--|
| 1 | 8-3-73 | JK | PER ECH 577C REMOVED CDR FROM FILTER APP'D. SKUD |
| 2 | 11-16-73 | JK | PER ECH 33690 R1 WAS 10W APP'D. SKH |
| 3 | 11-16-73 | JK | REMOVED PER RFA 0671 APP'D. SKH |
| 4 | 11-1-74 | JK | REVISED PER ECH 4393 APP'D. SKH |

| WANG PART NO | ITEM | QTY | NAME | MATERIAL | DESCRIPTION |
|--------------|---------------|--------------|--|--|---|
| | FIRST USED ON | ASSY USED ON | WANG LABORATORIES, INC. <small>TEMPERARY, MASS. U.S.A.</small> | | |
| | | | | | |
| | | | MATERIAL | MODEL NO 623/723, 624/724, 2224 | SI ENGR SPECIFICATIONS No |
| | | | FINISH | TOL. ER. AS NOTED <small>XX ± 010 FRAC ± 1/64 XXX ± 005 ANG ± 1°30' FINISH V</small> | |
| | | | | | TITLE BUFFER SCHEMATIC POWER SUPPLY 6281 |
| | | | | | BY OWN JB DATE 12/2/74 E ENGR J.W.V. 1-17-75 |
| | | | | | CHK. M ENGR MFG ENGR |
| | | | | | E & C CONTROL |
| | | | | | C 6281-1 4 |
| | | | | | SCALE SHT OF WANG PART NUMBER SIZE DRAWING NUMBER REV |

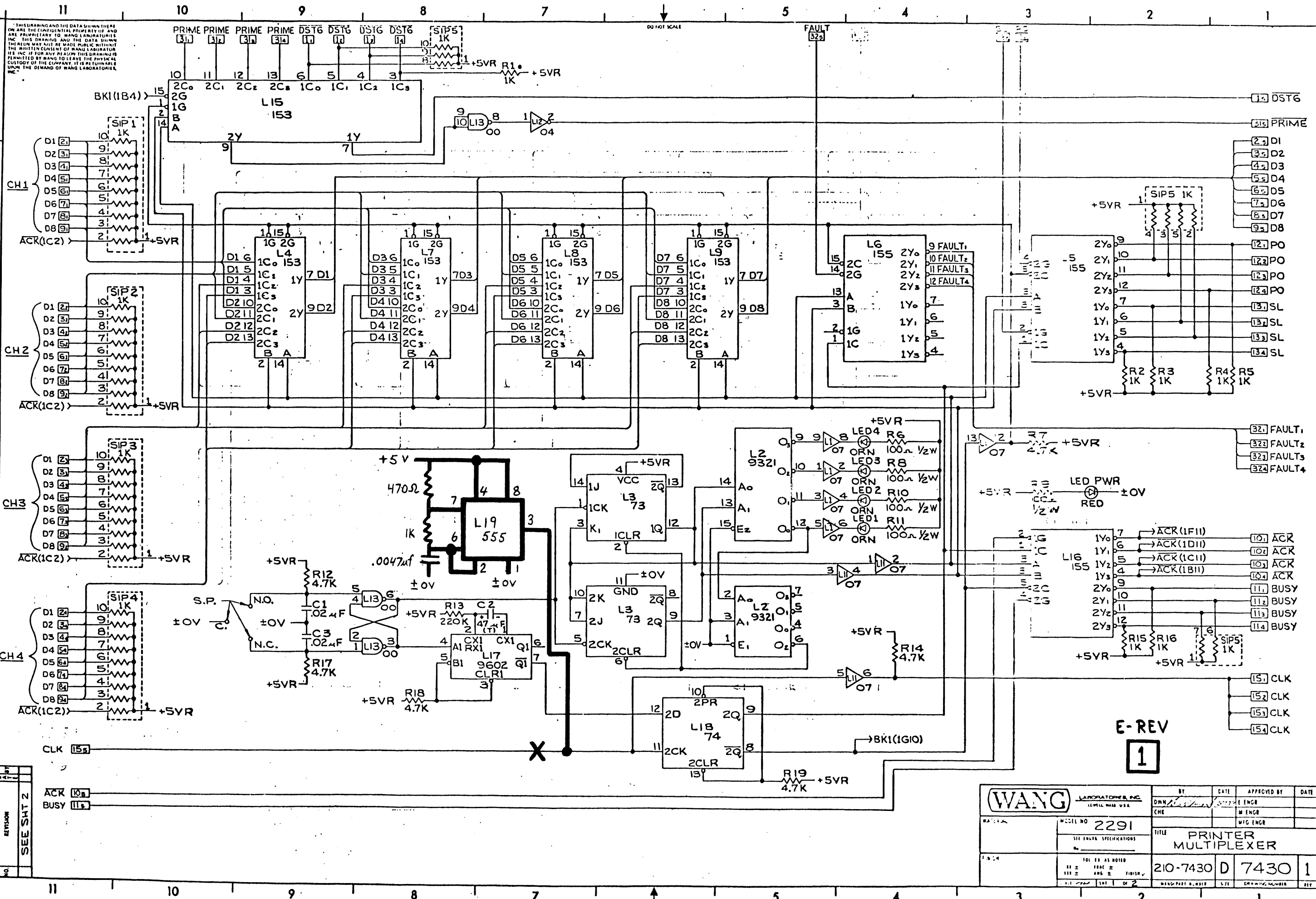

THIS DRAWING AND THE DATA SHOWN THEREON ARE THE CONFIDENTIAL PROPERTY OF WANG LABORATORIES, INC. THIS DRAWING AND THE DATA SHOWN HEREIN MAY NOT BE MADE PUBLIC WITHOUT THE WRITTEN CONSENT OF WANG LABORATORIES, INC. IF FOR ANY REASON THIS DRAWING IS PERMITTED BY WANG TO LEAVE THE PHYSICAL CUSTODY OF THE COMPANY, IT IS TO REMAIN THE PROPERTY OF WANG LABORATORIES, INC.

E-REV
1

| | | | | | |
|--|--|-------------------------|----------------------------|---------------------------------|---------------------|
| WANG LABORATORIES, INC. 100 WEST MAIN ST. WALTHAM, MASS. 01981 | | BY: <i>[Signature]</i> | DATE: <i>[Date]</i> | APPROVED BY: <i>[Signature]</i> | DATE: <i>[Date]</i> |
| MODEL NO. 2291 | | DRN: <i>[Signature]</i> | ENGR: <i>[Signature]</i> | | |
| SEE ENGR SPECIFICATIONS | | CHE: <i>[Signature]</i> | M ENGR: <i>[Signature]</i> | | |
| TITLE: PRINTER MULTIPLEXER | | | | | |
| 210-7430 D | | 7430 1 | | | |
| REV. 1 OF 2 | | DRAWING NUMBER: 7430 | | | |

REVISION
SEE SHT 2

THIS DRAWING AND THE DATA SHOWN THERE ON ARE THE CONFIDENTIAL PROPERTY OF AND ARE PROPRIETARY TO WANG LABORATORIES, INC. THIS DRAWING AND THE DATA SHOWN THEREON MAY NOT BE MADE PUBLIC WITHOUT THE WRITTEN CONSENT OF WANG LABORATORIES, INC. IF FOR ANY REASON THIS DRAWING IS PERMITTED BY WANG TO LEAVE THE PHYSICAL CUSTODY OF THE COMPANY, IT IS RETURNABLE UPON THE DEMAND OF WANG LABORATORIES, INC.

| I.C. LOCATION | TYPE | W.L. NO. |
|---------------|-------|----------|
| L1,11 | 7407 | 376-0056 |
| L2 | 9321 | 376-0096 |
| L3 | 7473 | 376-0005 |
| L4,7-9,15 | 74153 | 376-0048 |
| L5,6,16 | 74155 | 376-0049 |
| L10 | SPARE | |
| L12 | 7404 | 376-0010 |
| L13 | 7400 | 376-0002 |
| L14 | SPARE | |
| L17 | 9602 | 376-0104 |
| L18 | 7474 | 376-0006 |
| L19 | SPARE | |

| I.C. LOCATION | TYPE | SPARES |
|---------------|------|--------|
| L11 | 7407 | 2 |
| L12 | 7404 | 5 |
| L13 | 7400 | 1 |
| L17 | 9602 | 1 |
| L18 | 7474 | 1 |

| MNEMONIC | COORDINATE |
|---------------|-------------------------|
| ACK | 1A11,1C1 |
| BUSY | 1A11,1C1 |
| CLK | 1B11,1B1 |
| D1-8 | 1B11,1D11,1E11,1F11,1F1 |
| DST6 | 1G9,1G1 |
| FAULT | 1G5 |
| PO | 1G3,1F1 |
| PRIME | 1G10 |
| SL | 1G3,1E1 |
| PRIME | 1G1 |
| FAULT, -FAULT | 1D1 |

| COMPONENT | TYPE | W.L. NO. |
|----------------|---------------|----------|
| R1-5,15,16 | 1K 10% 1/4W | 330-3010 |
| R6,8-11 | 100Ω 10% 1/2W | 331-2010 |
| R7,12,14,17-19 | 4.7K 10% 1/4W | 330-3047 |
| R13 | 220K 10% 1/4W | 330-5022 |
| SIP1-5 | 1K 9/PKG | 333-0837 |
| C1,3 | .02μF 25V | 300-1904 |
| C2 | 47 μF 15V(T) | 300-4020 |
| C4 | 15 μF 20V(T) | 300-4022 |
| C5-12 | .05μF 12V | 300-1900 |
| LED1-4 | LAMP ORN | 370-0027 |
| LED PWR | LAMP RED | 370-0026 |
| J1-5 | 36PIN CONN | 350-0085 |

| NO. | REVISION | BY | DATE |
|-----|----------------|-----|-------------|
| 1 | ORIGINATED PER | 25A | 11-15-79 |
| 2 | DESIGNED BY | 25A | 11-15-79 |
| 3 | APP'D. BY | 25A | 11-15-79 |
| 4 | REV PER ECN | 25A | 11-22-APPD. |
| 5 | DATE | 25A | 11-22-79 |

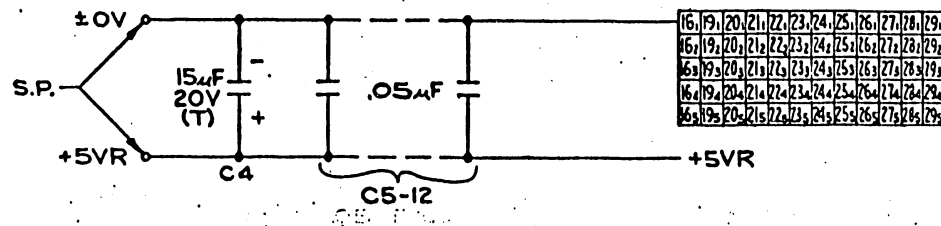
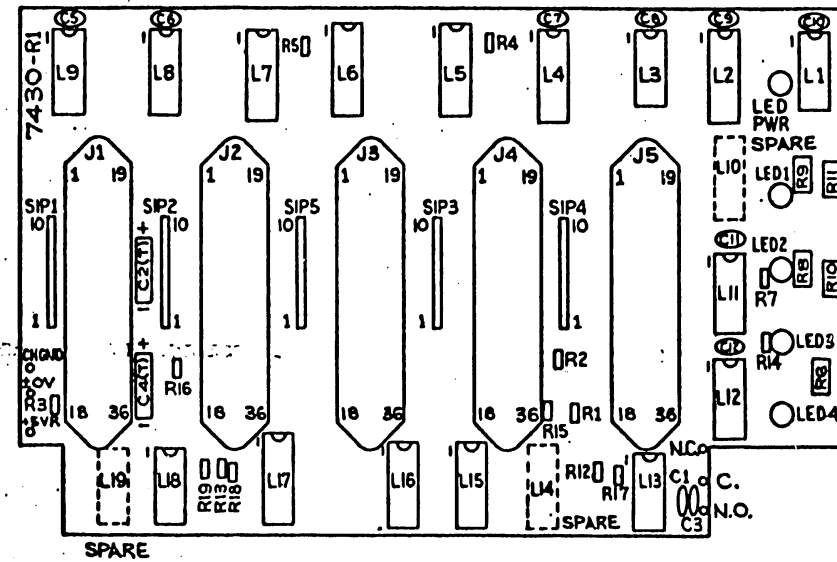
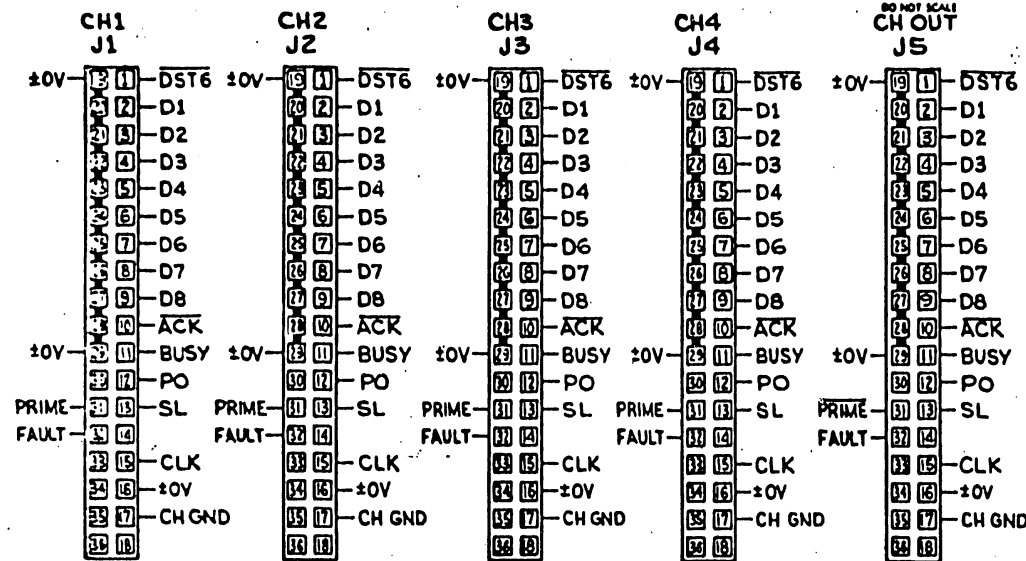

E REV
O

| | | | | | |
|---|------------------------------------|------------------------------|-----------------|-----------------------|------------------|
| WANG LABORATORIES, INC. LOWELL, MASS. USA | | BY DWN | DATE 5/27/79 | APPROVED BY E ENGR | DATE 11-22-79 |
| MATERIAL | MODEL NO. 2291 | TITLE PRINTER MULTIPLEXER | | MTG ENGR | |
| FINISH | TOL. AS NOTED ±.005 ±.005 ±.005 | 210-7430 | D | 7430 | 1 |
| SCALE 1:1 | | SHEET 2 OF 2 | | WANG PART NUMBER | SIZE |

United States

| | | | | | |
|--|---|--|---|--|---|
| Alabama Birmingham Mobile | Florida Miami Hialeah Jacksonville Orlando Tampa | Louisiana Baton Rouge Metairie | New Hampshire Manchester | Oregon Eugene Portland | Vermont Montpelier |
| Alaska Anchorage | | Maryland Rockville Towson | New Jersey Toms River Mountainside Clifton | Pennsylvania Allentown Camp Hill Erie Philadelphia Pittsburgh Wayne | Virginia Newport News Norfolk Richmond |
| Arizona Phoenix Tucson | Georgia Atlanta Savannah | Massachusetts Billerica Boston Burlington Chelmsford Lawrence Littleton Lowell Tewksbury Worcester | New Mexico Albuquerque | | Washington Richland Seattle Spokane Tacoma |
| California Culver City Fountain Valley Fresno Inglewood Sacramento San Diego San Francisco Santa Clara Ventura | Hawaii Honolulu | Michigan Kentwood Okemos Southfield | New York Albany Buffalo Fairport Lake Success New York City Syracuse | Rhode Island Cranston | Wisconsin Brookfield Madison Wauwatosa |
| Colorado Englewood | Idaho Idaho Falls | Minnesota Eden Prairie | North Carolina Charlotte Greensboro Raleigh | South Carolina Charleston Columbia | |
| Connecticut New Haven Stamford Wethersfield | Illinois Chicago Morton Park Ridge Rock Island Rosemont | Missouri Creve Coeur | Ohio Cincinnati Cleveland Middleburg Heights Toledo Worthington | Tennessee Chattanooga Knoxville Memphis Nashville | |
| District of Columbia Washington | Indiana Indianapolis South Bend | Nebraska Omaha | Oklahoma Oklahoma City Tulsa | Texas Austin Dallas Houston San Antonio | |
| | Kansas Overland Park Wichita | Nevada Las Vegas Reno | | Utah Salt Lake City | |

International Offices

| | | |
|---|--|--|
| Australia Wang Computer Pty., Ltd. Adelaide, S.A. Brisbane, Qld. Canberra, A.C.T. Darwin N.T. Perth, W.A. South Melbourne, Vic 3 Sydney, NSW | France Wang France S.A.R.L. Paris Bordeaux Lyon Marseilles Nantes Strasbourg Toulouse | Singapore Wang Computer (Pte) Ltd. Singapore |
| Austria Wang Gesellschaft, m.b.H. Vienna | Great Britain Wang (U.K.) Ltd. Richmond Birmingham London Manchester Northwood Hills | Sweden Wang Skandinaviska AB Stockholm Gothenburg Malmo |
| Belgium Wang Europe, S.A. Brussels Erpe-Mere | Hong Kong Wang Pacific Ltd. Hong Kong | Switzerland Wang A.G. Zurich Basel Geneva |
| Canada Wang Laboratories (Canada) Ltd. Burnaby, B.C. Calgary, Alberta Don Mills, Ontario Edmonton, Alberta Hamilton, Ontario Montreal, Quebec Ottawa, Ontario Winnipeg, Manitoba | Japan Wang Computer Ltd. Tokyo | Wang Trading A.G. Zug |
| China Wang Industrial Co., Ltd. Taipei Wang Laboratories Ltd Taipei | Netherlands Wang Nederland B.V. IJsselstein Gronigen | United States Wang International Trade, Inc. Lowell, Mass. |
| | New Zealand Wang Computer Ltd. Auckland Wellington | West Germany Wang Laboratories, GmbH Frankfurt Berlin Cologne Dusseldorf Essen Freiburg Hamburg Hannover Kassel Munich Nurnberg Saarbrucken Stuttgart |

International Representatives

| | |
|--|---|
| Abu-Dhabi Argentina Bahrain Bolivia Brazil Canary Islands Chile Colombia Costa Rica Cyprus Denmark Dominican Republic Ecuador Egypt El Salvador Finland Ghana Greece Guatemala Haiti Honduras Iceland India Indonesia Ireland Israel Italy Jamaica Japan Jordan | Kenya Korea Kuwait Lebanon Liberia Malaysia Malta Mexico Morocco Nicaragua Nigeria Norway Paraguay Peru Philippines Portugal Saudi Arabia Scotland Spain Sri Lanka Sudan Syria Thailand Turkey United Arab Emirates Venezuela |
|--|---|

WANG

LABORATORIES, INC.

ONE INDUSTRIAL AVENUE, LOWELL, MASSACHUSETTS 01851, TEL. (617) 459-5000, TWX 710 343-6769, TELEX 94-7421

Printed in U.S.A.
13-6339
1-80-5M

END