

REVISIONS					
LTR.	DESCRIPTION	DATE	AUTH.	DR.	CK.

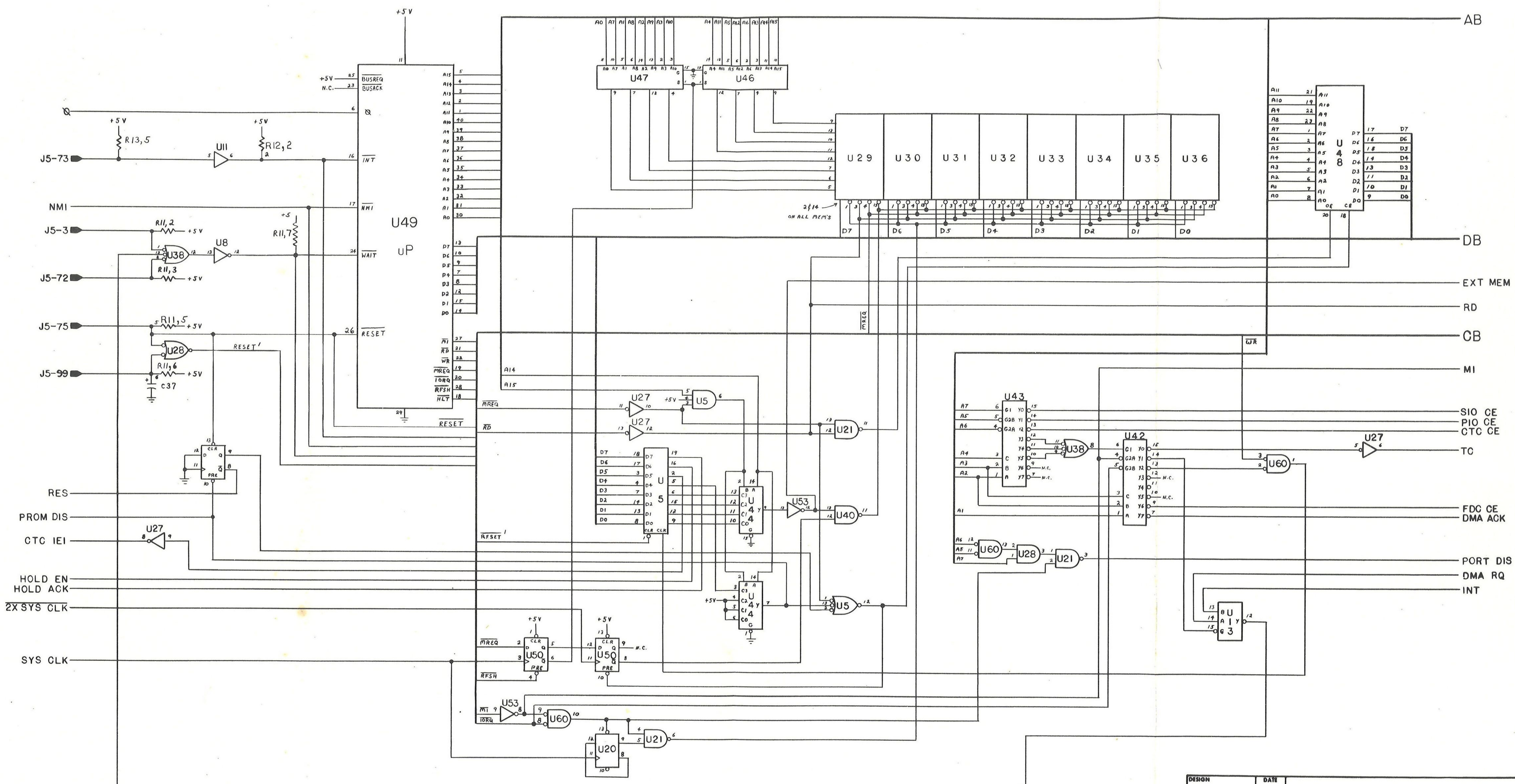

DESIGN	DATE	SDS MASTER I - SBC-100
DRAWN	JMF	
APPROVED	SAB	TITLE
CHECKED		PROCESSOR, MEMORY, PORT DECODING
MADE FROM		DRAWING NUMBER
REMARKS		REV.
		A
SCALE	RELEASED EM NO.	SHEET 2 OF 5

REVISIONS					
LTR.	DESCRIPTION	DATE	AUTH.	DR.	CK.

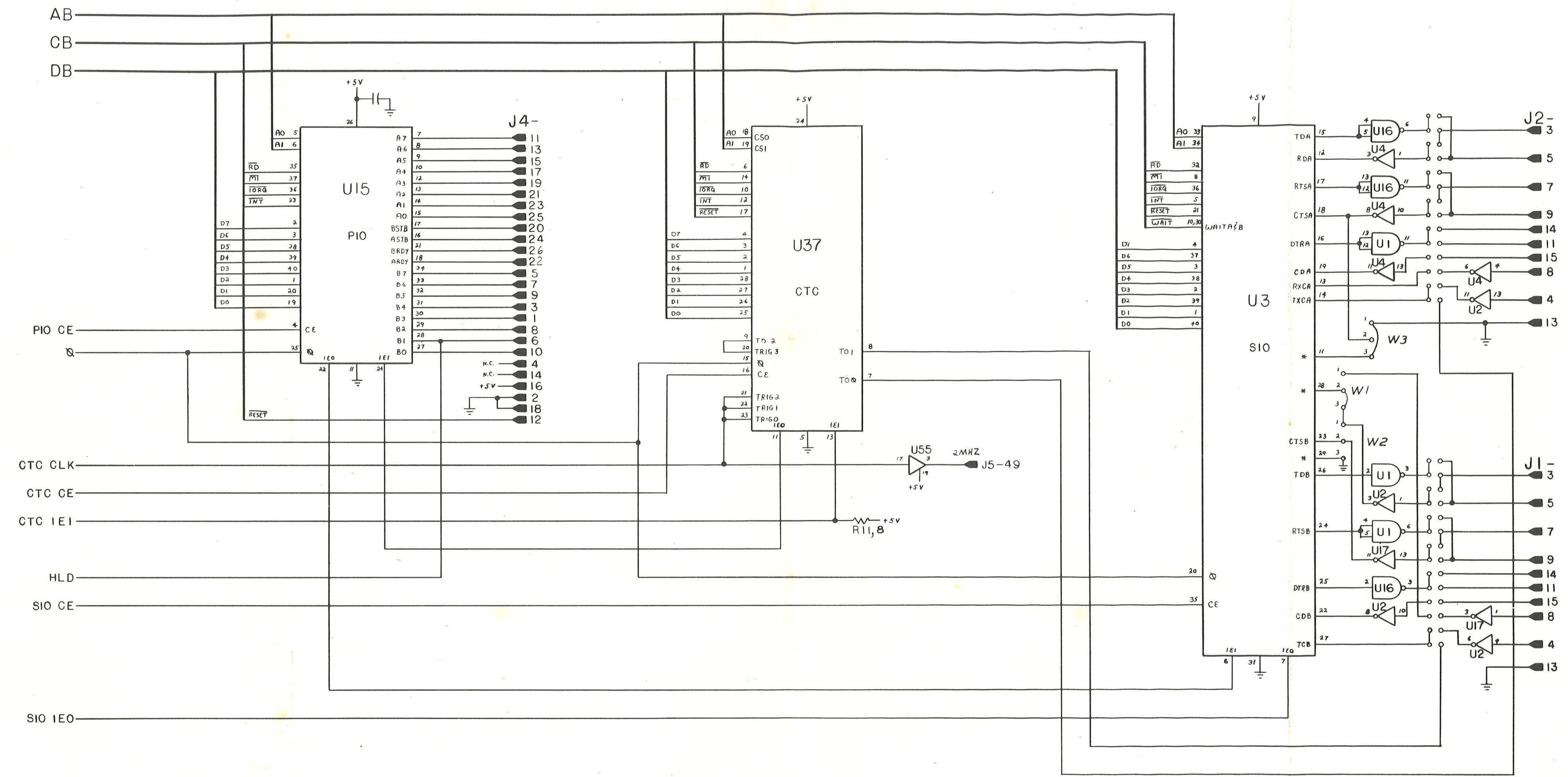

DESIGN	DATE	SDS MASTER I SBC-100	
DRAWN	JMF	TITLE	
APPROVED	SAB	PIO, SIO, CTC	
CHECKED		DRAWING NUMBER	
MADE FROM		REV.	
REMARKS		A	
SCALE	RELEASED EM NO.	SHEET	3 OF 5

REVISIONS					
LTR.	DESCRIPTION	DATE	AUTH.	DR.	CK.

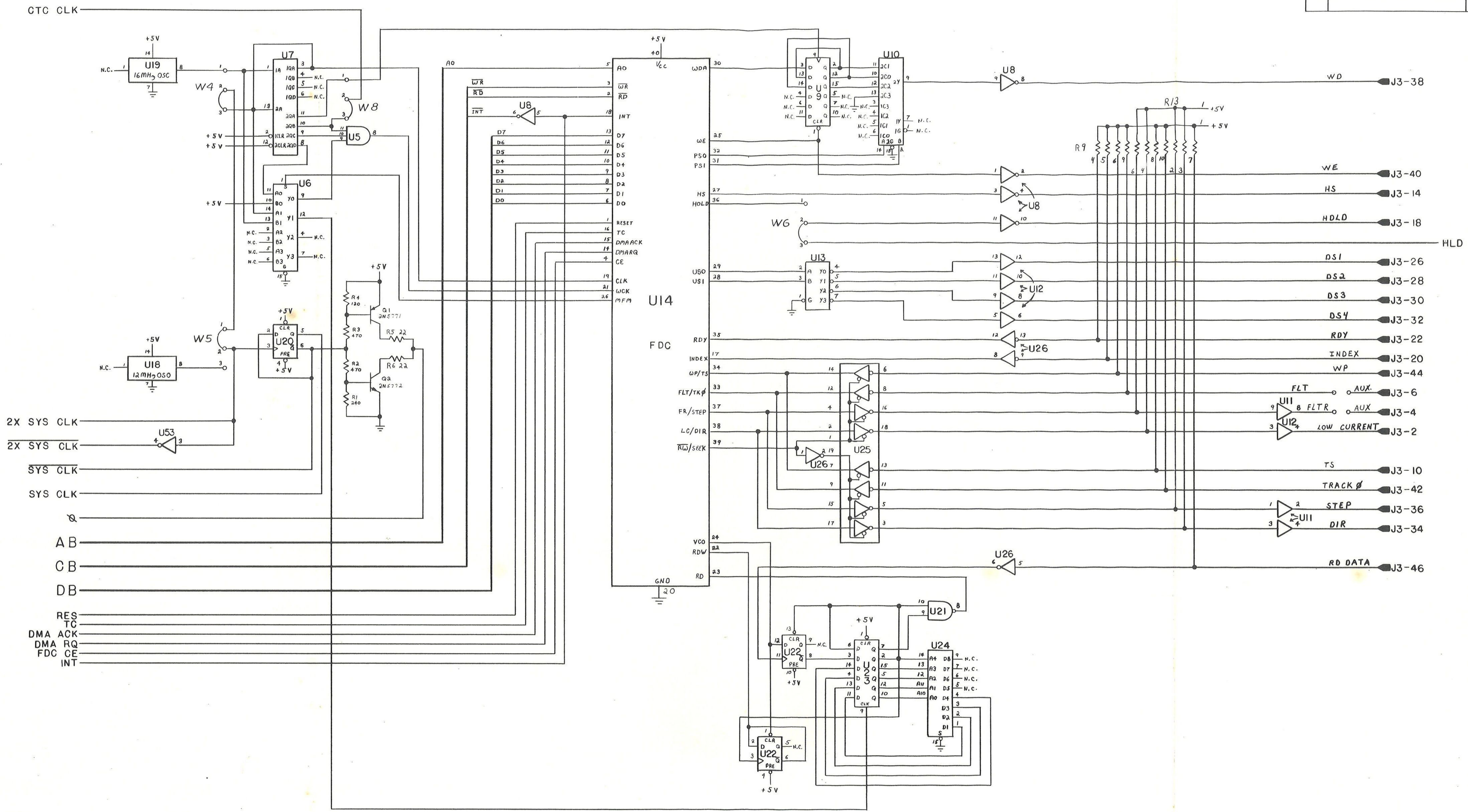

- CTC CLK
- +5V
- N.C.
- W4
- W5
- W6
- 2X SYS CLK
- 2X SYS CLK
- SYS CLK
- SYS CLK
- Q
- AB
- CB
- DB
- RES
- TC
- DMA ACK
- DMA RQ
- FDC CE
- INT

DESIGN	DATE	SDS MASTER I - SBC-100 TITLE CLOCK, FDC DRAWING NUMBER REV. A		
DRAWN	JWF			
APPROVED	SAB			
CHECKED				
MADE FROM				
REMARKS		SCALE	RELEASED EM NO.	SHEET 4 OF 5

REVISIONS					
LTR.	DESCRIPTION	DATE	AUTH.	DR.	CK.

AB

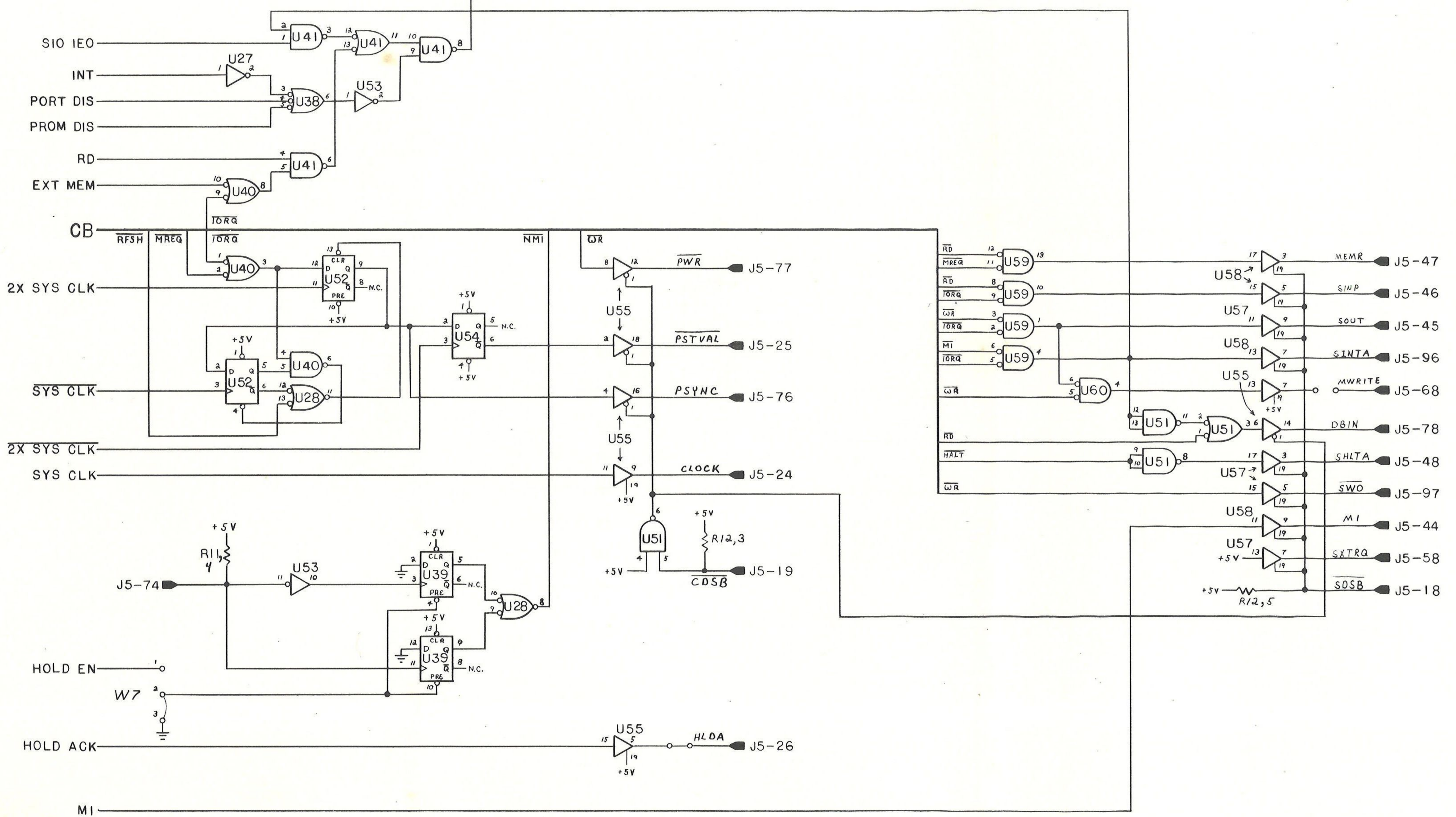
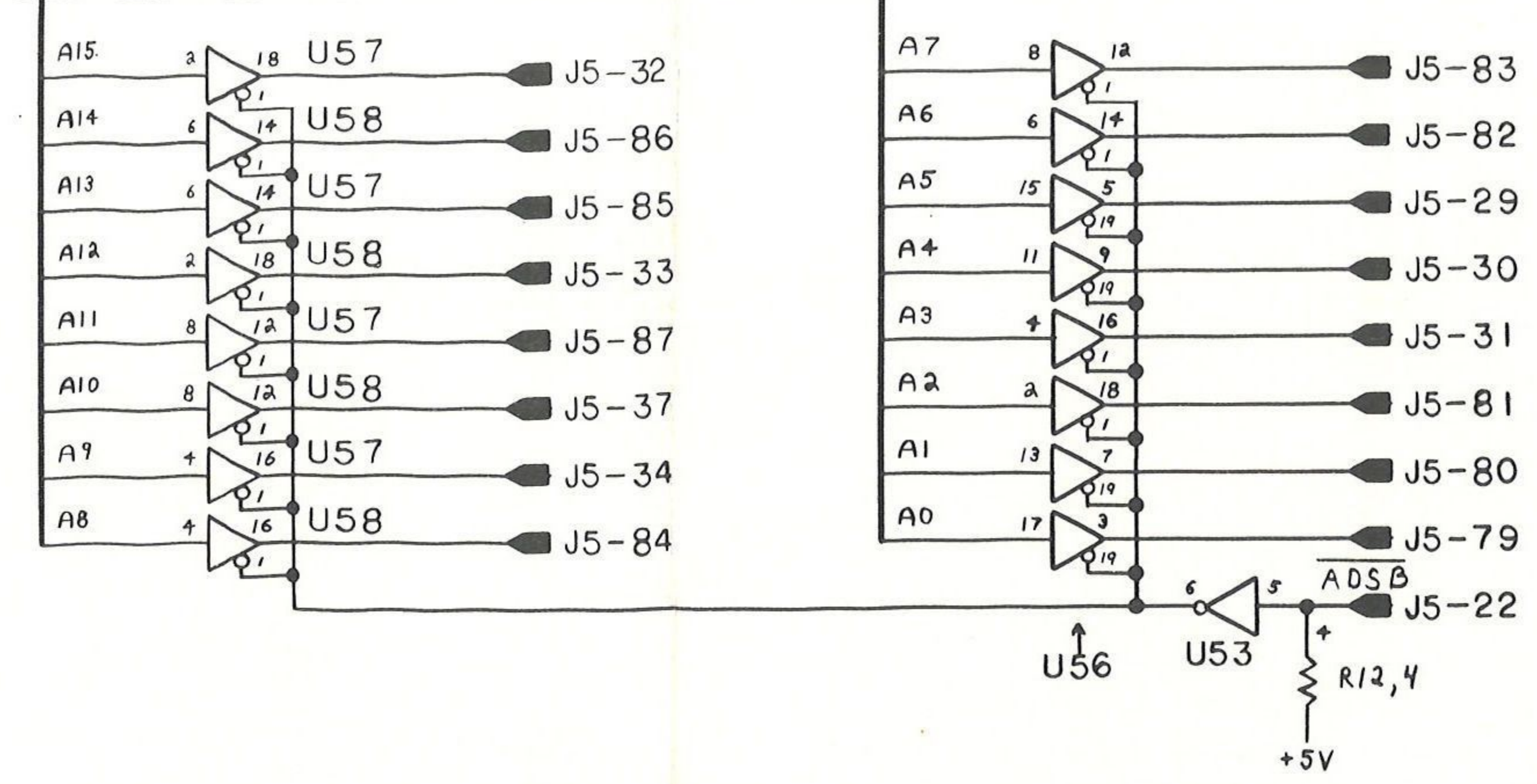
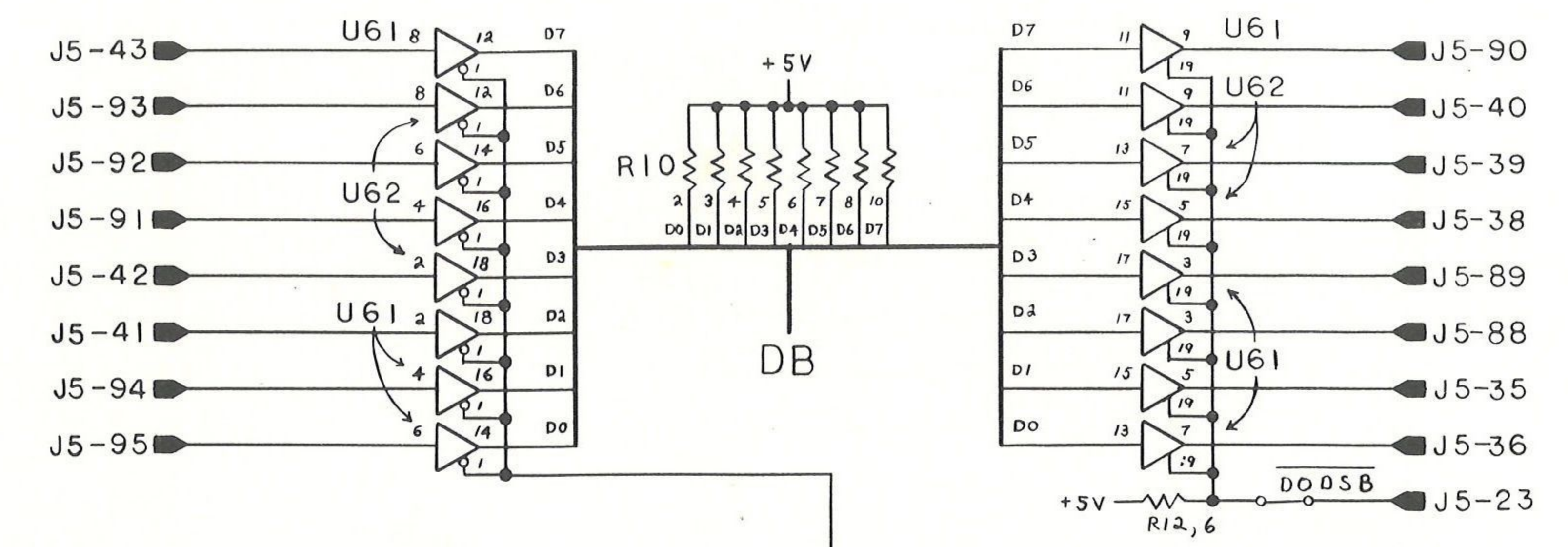

DESIGN	DATE	SDS MASTER I SBC-100	
DRAWN	JMF	TITLE	
APPROVED	SAB	S-100 INTERFACE	
CHECKED		DRAWING NUMBER	
MADE FROM		REV. A	
REMARKS		SCALE	RELEASED EM NO.
		SHIRT	OF 5

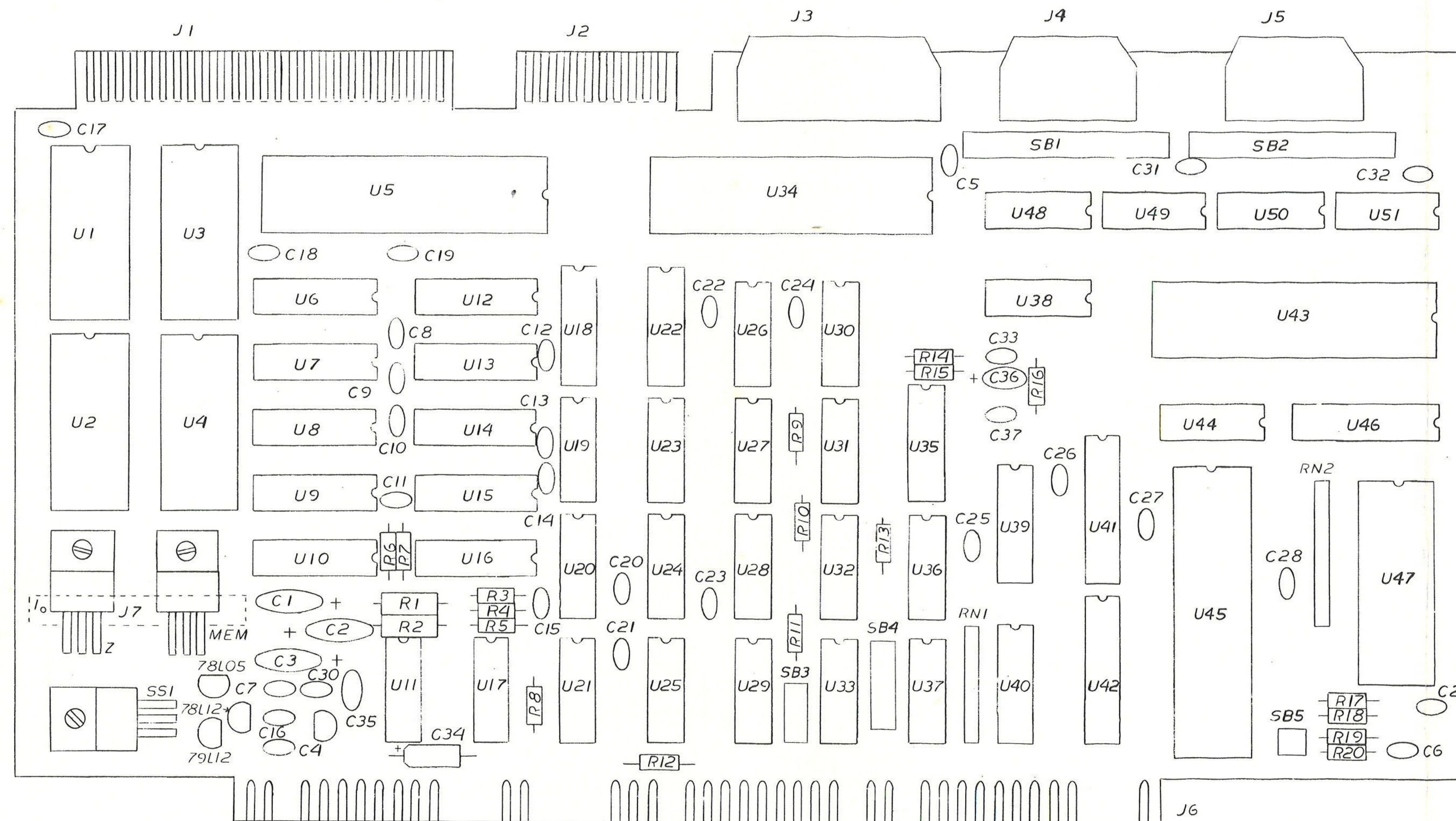

NOTES:

- C1 - +12
- C2 - -12
- C3 - +5
- C4 - C7 - ZILOG
- C7 - C15 - MEMORY
- C16 - C29 - +5 MSI/SSI
- C30 - 105 BYPASS
- C31 - -12 BYPASS
- C32 - +12 BYPASS
- C33 - WAIT CAP DURING PROM BURNING
- C34 - TL497 OUTPUT FILTER
- C35 - TL497 FREQ CONTROL
- C36 - POC CAP
- C37 - RESET TIME CAP

- R1 - +12
- R2 - -12
- R3 - CLK P.U.
- R4 - 2N3643 C.B.
- R5 - CL RES
- R6 - P.B. HIGH
- R7 - P.B. REF
- R8 - 7406 P.U. (PIN 8)
- R9 - XOR P.U. (BS)
- R10 - S-100 IEI P.U.
- R11 - XOR PORT DEC. P.U.
- R12 - OPTIONAL P.U. TO S-100/75
- R13 - WAIT P.U.
- R14 - P.B. TIMER RES.

- R15 - POC P.U.
- R16 - RES. TIME
- R17 - INT P.U.
- R18 - IEI TO CTC P.U.
- R19 - BRDY P.U.
- R20 - ARDY P.U.

SDS SLAVE-I SBC-100S

SCALE: NONE	APPROVED BY:	DRAWN BY: SAE
DATE:		REVISED REV. A
Component Placement		DRAWING NUMBER
Sheet 1 of 4		

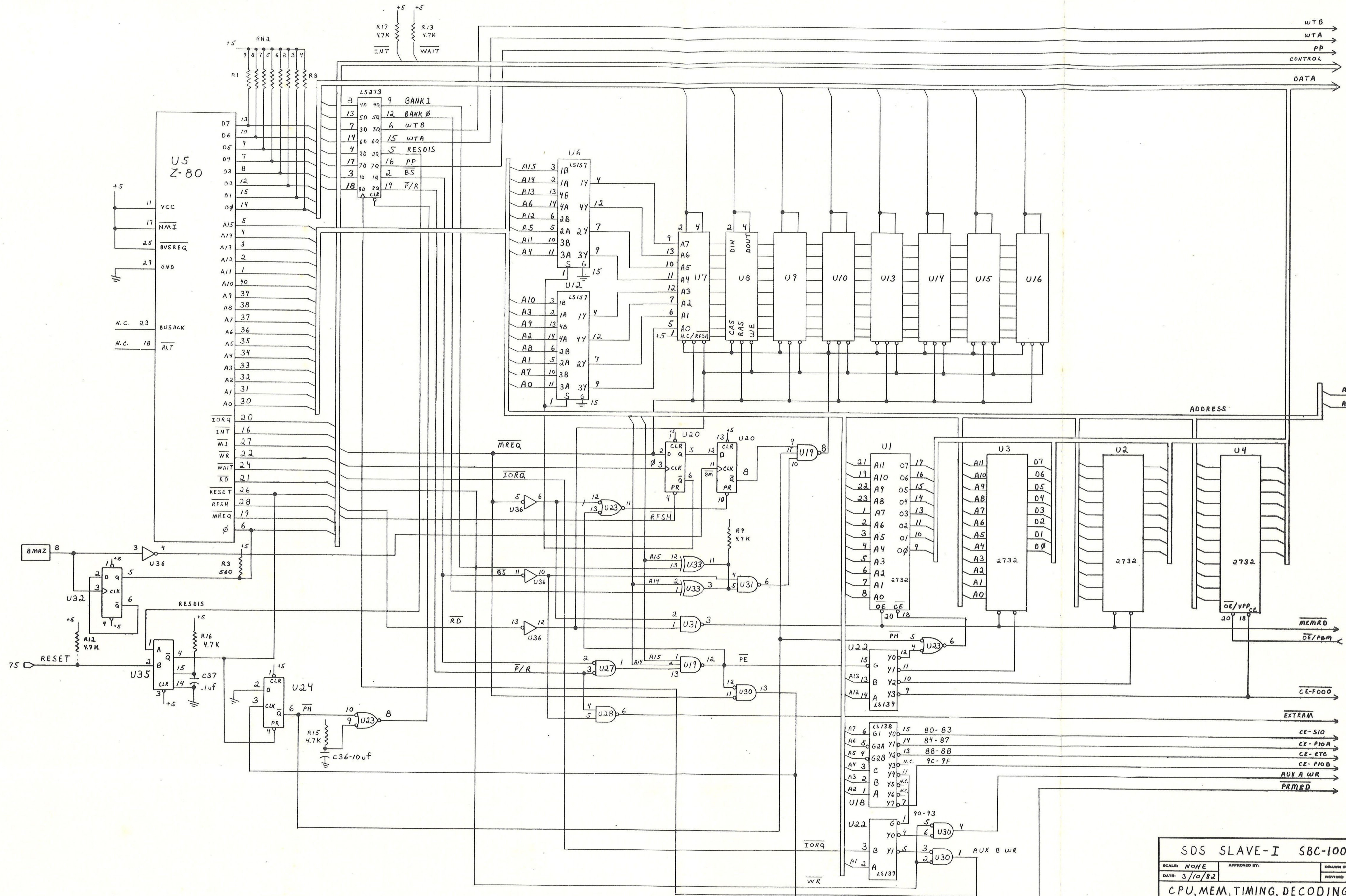

SDS SLAVE-I SBC-100S
 SCALE: NONE APPROVED BY: DRAWN BY: SAB
 DATE: 3/10/82 REVISED REV. A
 CPU, MEM, TIMING, DECODING
 Sheet 2 of 4

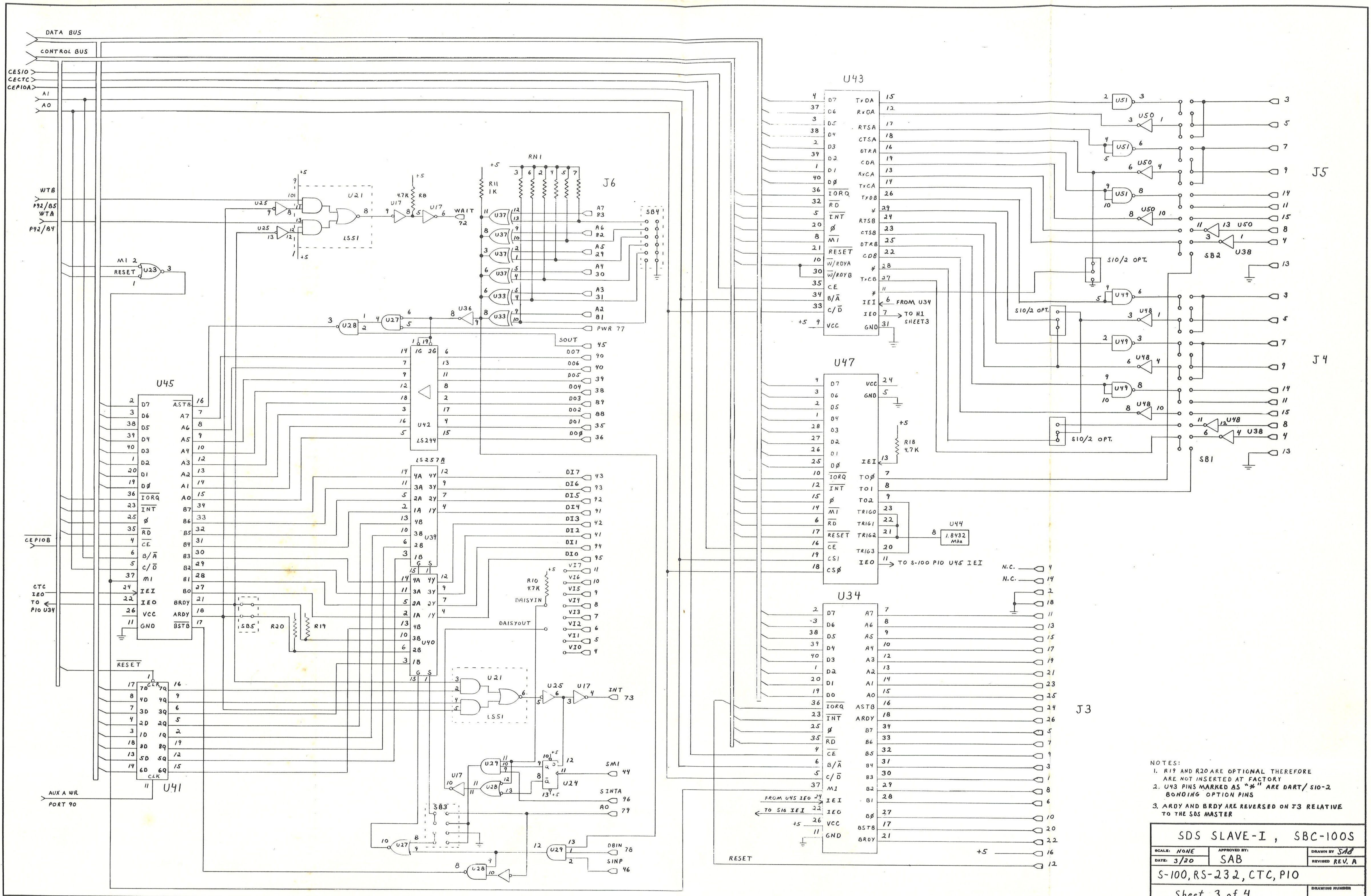

- NOTES:
- R19 AND R20 ARE OPTIONAL THEREFORE ARE NOT INSERTED AT FACTORY BONDING OPTION PINS
 - U43 PINS MARKED AS "*" ARE DART/SIO-2 BONDING OPTION PINS
 - ARDY AND BRDY ARE REVERSED ON J3 RELATIVE TO THE SDS MASTER

SDS SLAVE-I, SBC-100S		
SCALE: NONE	APPROVED BY: SAB	DRAWN BY: SAB
DATE: 3/20	SAB	REVISED: REV. A
S-100, RS-232, CTC, PIO		
Sheet 3 of 4		DRAWING NUMBER

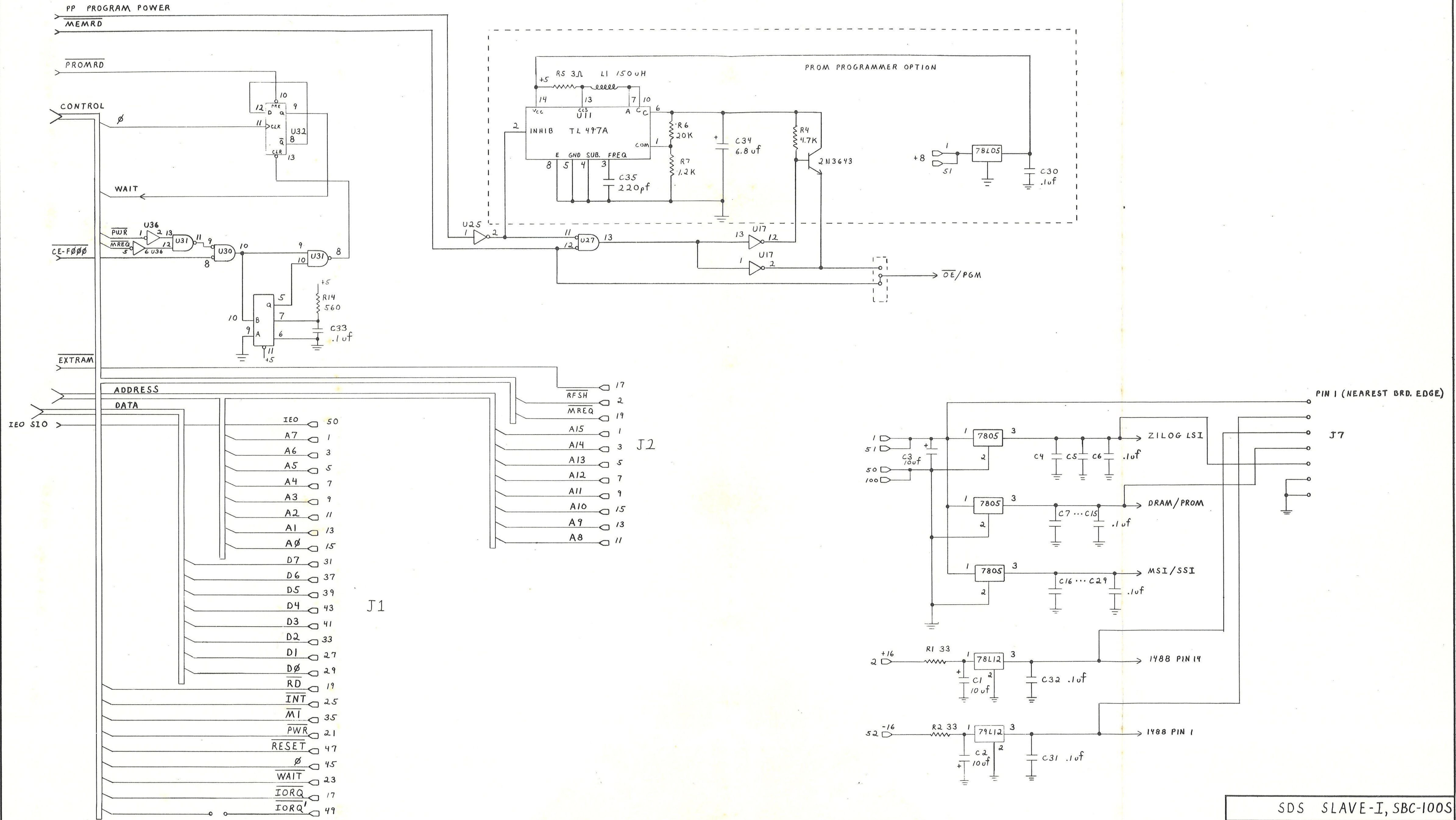

SDS SLAVE-I, SBC-100S		
SCALE: NONE	APPROVED BY:	DRAWN BY: SJB
DATE: 4/15/82		REVISED: REV. A
X-BUSS, WAIT, POWER, PRM.PGM.OPT.		
Sheet 4 of 4		
DRAWING NUMBER		

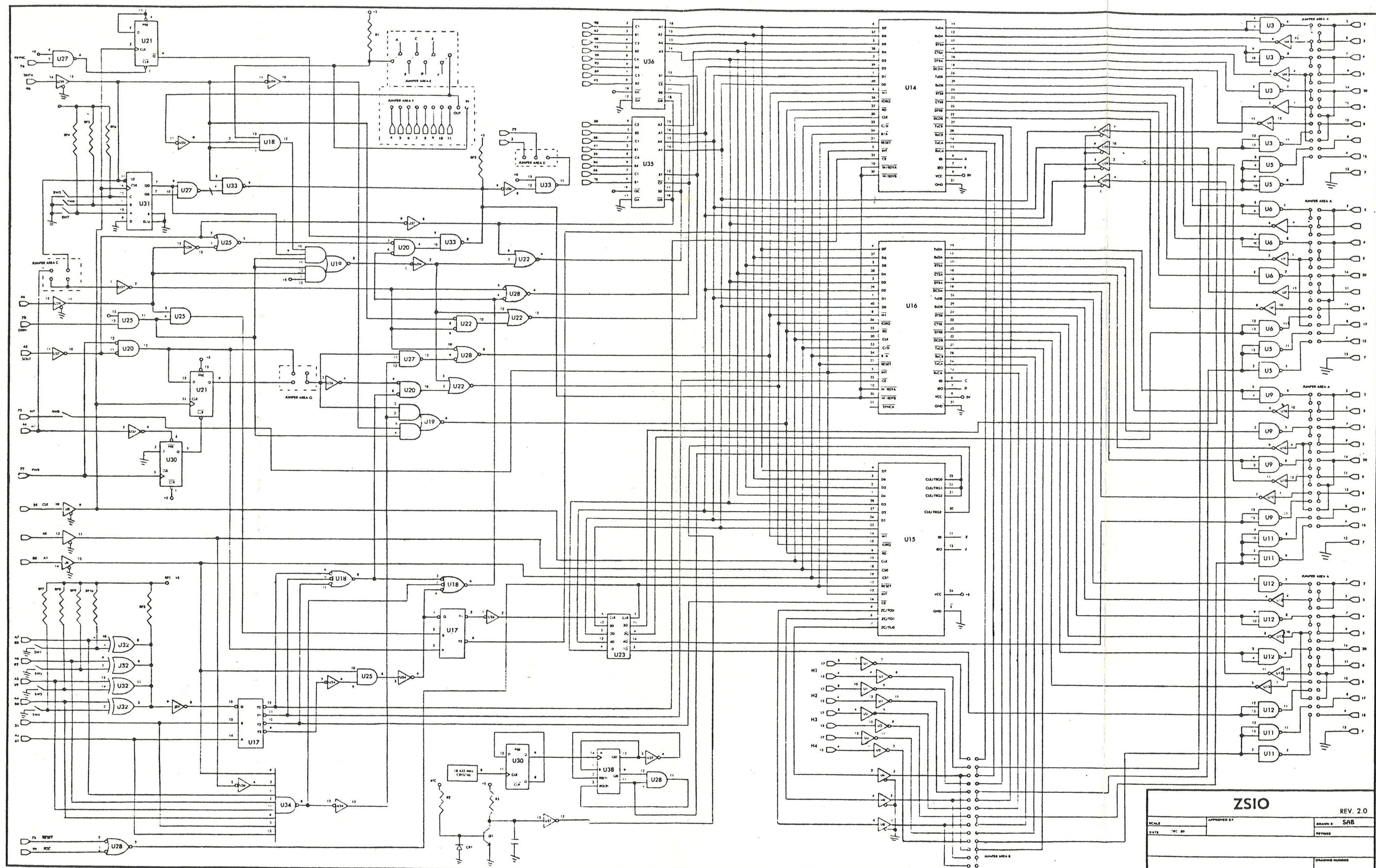

ZSIO		REV. 2.0
SCALE	APPROVED BY	DRAWN BY
DATE	DATE	REVISION
		DRAWING NUMBER

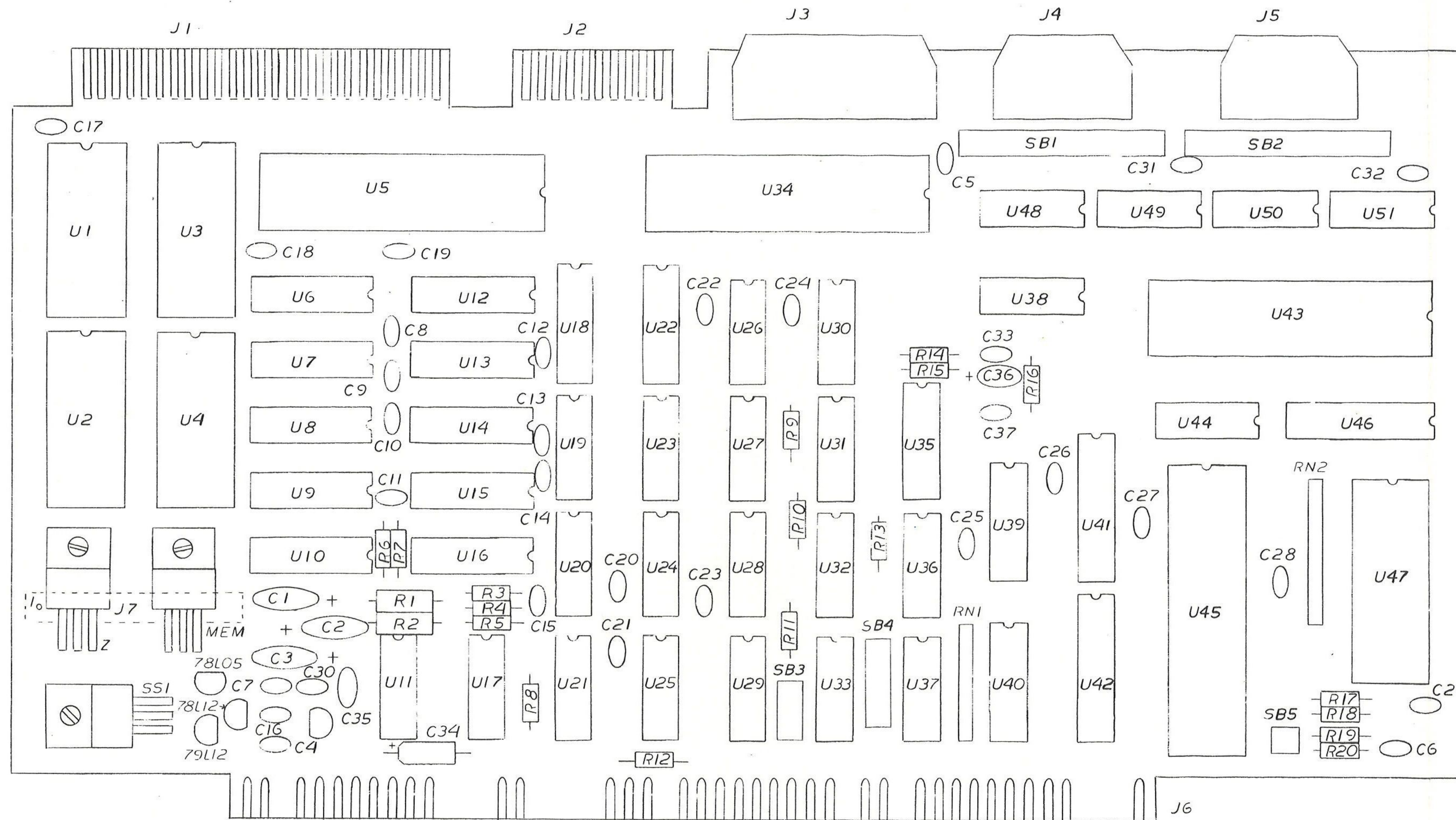

NOTES:

- C1 - +12
- C2 - -12
- C3 - +5
- C4-C7 - ZILOG
- C7-C15 - MEMORY
- C16-C29 - +5 MSI/SSI
- C30 - 105 BYPASS
- C31 - -12 BYPASS
- C32 - +12 BYPASS
- C33 - WAIT CAP DURING PROM BURNING
- C34 - TL497 OUTPUT FILTER
- C35 - TL497 FREQ CONTROL
- C36 - POC CAP
- C37 - RESET TIME CAP

- R1 - +12
- R2 - -12
- R3 - CLK P.U.
- R4 - 2N3643 C.B.
- R5 - CL RES
- R6 - P.B. HIGH
- R7 - P.B. REF.
- R8 - 7406 P.U. (PIN 8)
- R9 - XOR P.U. (B5)
- R10 - S-100 IEI P.U.
- R11 - XOR PORT DEC. P.U.
- R12 - OPTIONAL P.U. TO S-100/75
- R13 - WAIT P.U.
- R14 - P.B. TIMER RES.

- R15 - POC P.U.
- R16 - RES. TIME
- R17 - INT P.U.
- R18 - IEI TO CTC P.U.
- R19 - BRDY P.U.
- R20 - ARDY P.U.

SDS SLAVE-I SBC-100S

SCALE: NONE APPROVED BY: DRAWN BY: SAG
 DATE: REVISED REV. A

Component Placement

Sheet 1 of 4

DRAWING NUMBER

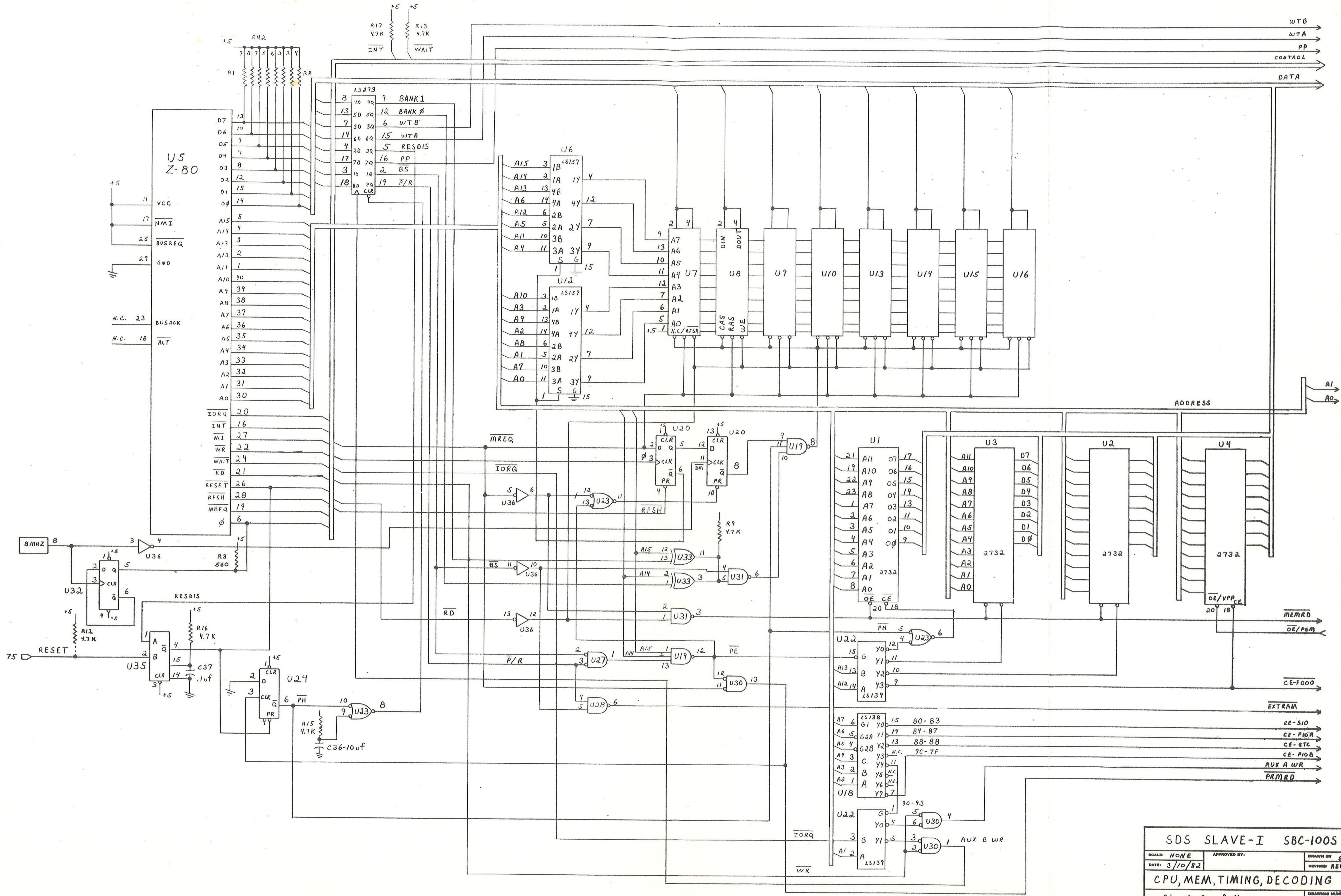

SDS SLAVE-I SBC-100S

SCALE: NONE APPROVED BY: DRAWN BY: SAB

DATE: 3/10/82 REVISED REV. A

CPU, MEM, TIMING, DECODING

Sheet 2 of 4

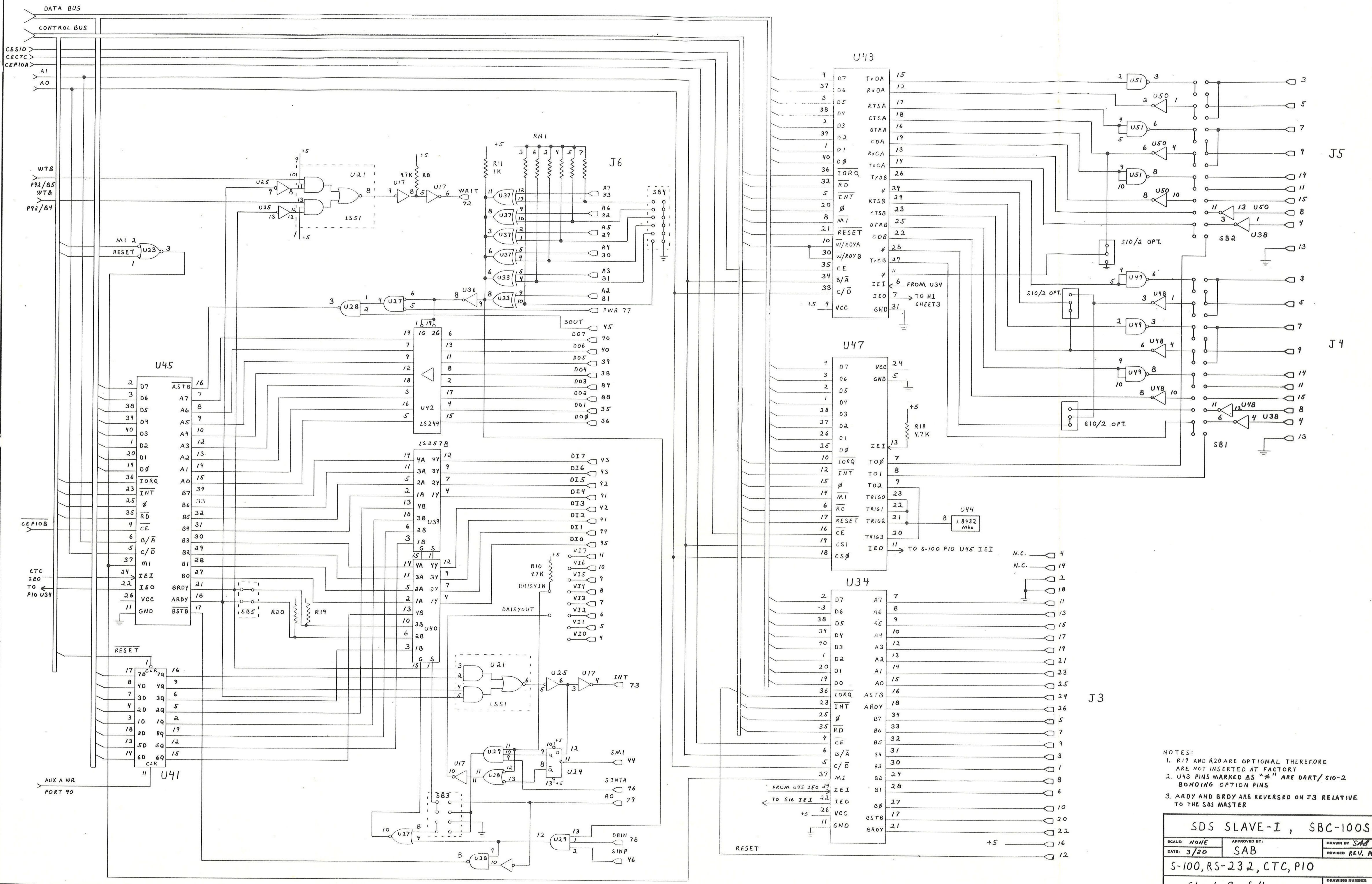

- NOTES:
1. R19 AND R20 ARE OPTIONAL THEREFORE ARE NOT INSERTED AT FACTORY
 2. U43 PINS MARKED AS "*" ARE DART/S10-2 BONDING OPTION PINS
 3. ARDY AND BRDY ARE REVERSED ON J3 RELATIVE TO THE S05 MASTER

SDS SLAVE-I, SBC-100S		
SCALE: NONE	APPROVED BY: SAB	DRAWN BY: SAB
DATE: 3/20		REVISED: REV. A
S-100, RS-232, CTC, PIO		
Sheet 3 of 4		DRAWING NUMBER

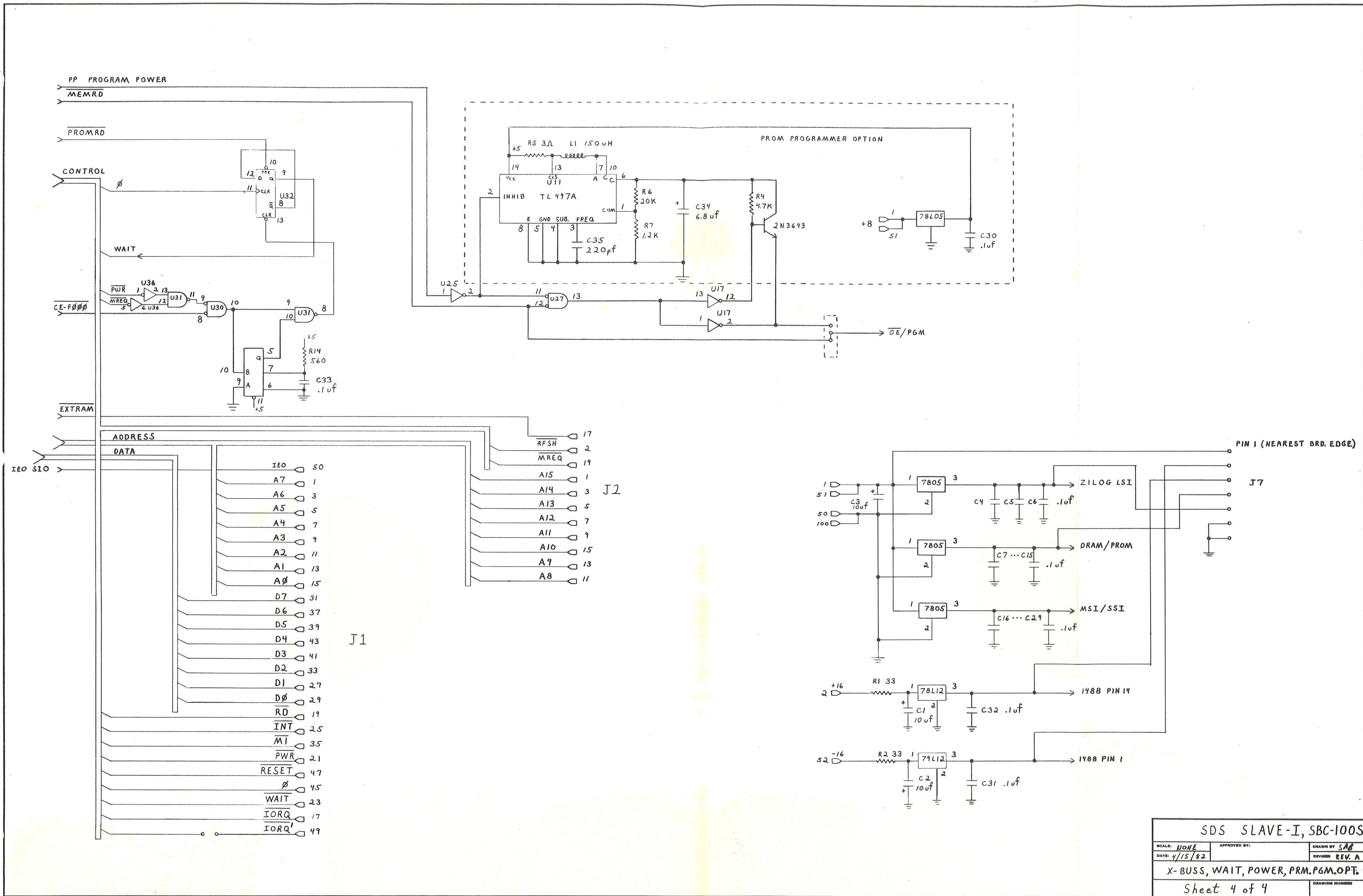

SDS SLAVE-I, SBC-100S		
SCALE: NONE	APPROVED BY:	DRAWN BY: SAB
DATE: 4/15/82		REVISED: REV. A
X-BUSS, WAIT, POWER, PRM.PGM.OPT.		DRAWING NUMBER:
Sheet 4 of 4		