Capacity

- 6.38 megabytes unformatted, 5.0 megabytes formatted on removable MicroDisc cartridge

Application

- Lowest cost rotating memory for portable computers
- Fast, reliable backup for fixed Winchester
- Program transfer
- Data transfer

Ease of Use

- Cartridge can be inserted or removed at any time without damage to cartridge or system
- Complete mirror image backup of ST406 (5 megabytes) in less than two minutes

Reliability

- Projected service life: in excess of 11,000 hours MTBF
- Positive cartridge interchangeability (less than 1 failure per 10,000 insertions)
- High durability head/disc
- High resistance to shock and vibration during transportation
- Sealed cartridge
- Head retracts automatically when cartridge is removed
- Heads are loaded on non-spinning disc
- Automatic purge cycle when new cartridge is inserted
- Automatic head calibration performed in less than one second
- Proven Seagate actuator design
- Low heat dissipation (25 watts, typical)
- Thermally isolated stepper and spindle motors
- One year warranty

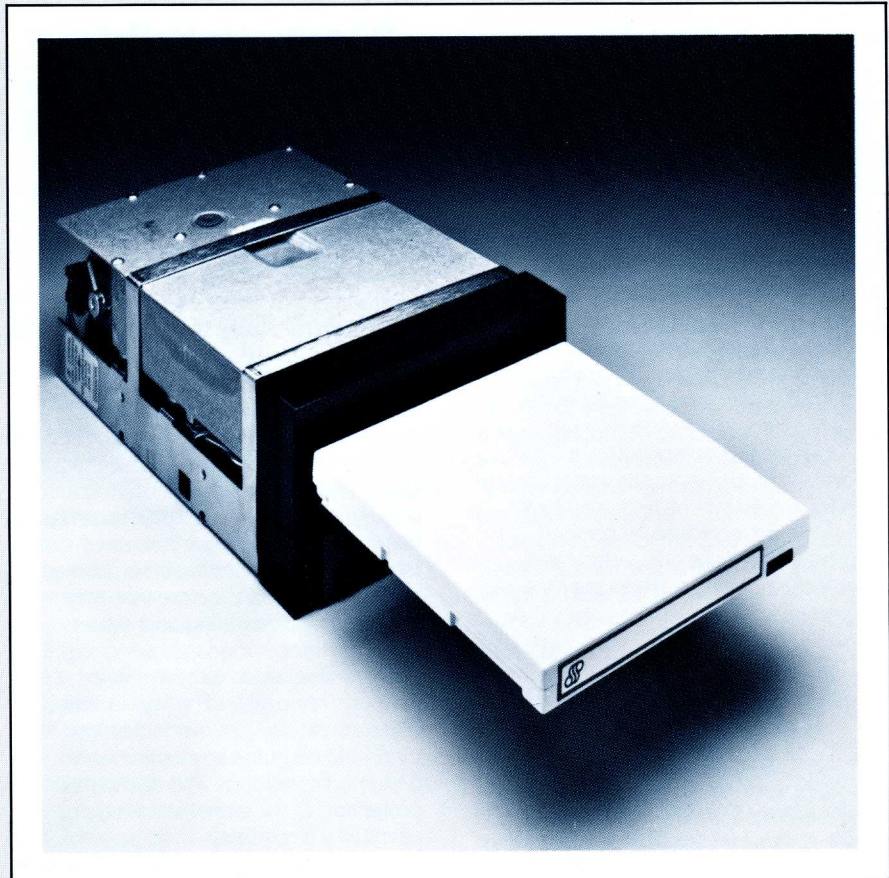

Data Integrity

- Same low error rate as ST412
- Integral write protect plug

Performance

- Advanced stepper motor design
- Manganese-zinc heads
- Onboard microcomputer
- Access time, average: 85 milliseconds
- Buffered seek

Easy Integration

- Compatible interfacing with Seagate ST506 and ST400 Series disc drives
- Same physical size and mounting as ST506, ST400 Series, and minifloppy disc drive
- Same DC voltage as ST506, ST400 Series, and minifloppy
- No AC power required

**“Turning the tide
in disc technology”**

Seagate's Freedom Generation

Seagate's ST706 drive combines the reliability and data access speed of Winchester technology with the portability of a 5¼-inch removable cartridge. You can use the disc cartridge in applications calling for removable data. Or use it with Seagate ST400 Series fixed discs for I/O, program loading and backup.

The ST706 offers a capacity of 6.38 megabytes unformatted, 5.0 megabytes formatted—the same capacity as the Seagate ST406 and ST506.

Manganese-zinc heads and an advanced stepper motor design enable high track density. The improved head design allows increased bit packing, utilizing more of the disc surface and double the number of tracks over the original micro-Winchester.

Better Than Other Removable Media

Five megabytes per cartridge give you more capacity than floppy or minifloppy media. Random access delivers faster speed than tape. And Winchester technology guarantees better data integrity and systems reliability than floppy or tape. It is ideal for portable computers.

The ST706 cartridge drive can produce a complete mirror image backup of an ST406 disc in less than two minutes. And the soft error rate is much better than tape backup. In addition, you can share the same controller as the ST400 Series fixed disc drive.

The **MicroDisc** cartridge utilized by the ST706 has been accepted as the industry standard for 5¼-inch removable cartridge disc drives.

Easy integration. Physical integration, controller design and software implementation are far easier than tape or floppy for backup. The ST706 is compatible in form factor, interfacing and power requirements with our ST506 and ST400 Series drives. Commonality in transfer rate, access method, and command sets allow use of one simple, compact controller. Automatic copy, flagging of bad sectors, error correction, and other value-added features can be integrated into the controller design at low cost.

Winchester Reliability

The ST706 brings Winchester reliability to removable data storage. Under typical usage, MTBF is rated the same as Seagate's fixed disc models—11,000 power on hours. No preventive maintenance is required.

This high reliability results from maintaining the protected read/write environment of Winchester technology in a sealed cartridge. When the **MicroDisc** is inserted into the drive, an automatic purge cycle cleans the read/write chamber. Automatic head calibration is performed, as needed, within one second.

A fixed guide together with a magnetic chuck and a three-point centering mechanism provide simple, reliable cartridge loading. A proprietary "no bounce" locking action assures positive positioning of the cartridge disc before operation. This positive positioning also assures cartridge interchangeability.

Automatic head retraction with cartridge removal and highly durable disc surfaces prevent media damage, even when the cartridge is removed under power off conditions. This also provides protection to the stored data when portability is required.

The ST706 uses proven Seagate positioning and drive mechanisms. High reliability is assured through the use of a proven metal band actuator, stepper head positioner, and direct drive brushless DC motor. The dynamically balanced motor/spindle assembly and a shock mounted baseplate reduce vibration.

The low load force and mass of Winchester flying heads and the high durability thin magnetic coated media on a 130 mm diameter aluminum substrate provide reliable contact start/stop operation. Each disc surface is read by a dedicated read/write head.

Fully enclosed discs and the read/write heads are protected by an integral recirculation air system with an absolute filter. Greater off-track margin is possible due to an extremely low temperature rise. Stepper and spindle motors are thermally isolated. Heat dissipation is rated at 25 watts, typical.

Only DC voltages (+12 and +5 VDC) are required. All electronics are packaged on two printed circuit boards. The boards are conveniently mounted to allow quick access and easy field repair.

The ST706 cartridge drive carries a one year warranty.

Winchester Performance

An advanced stepper motor, metal band actuator and the onboard micro-computer's buffered seek offer an average access time, including settling, of 85 milliseconds. The maximum access time is 205 milliseconds. Track-to-track access is three milliseconds.

Extra Assurance of Quality

Seagate Technology manufactures, tests and ships disc drives of consistently high quality. The Seagate manufacturing facilities have been designed exclusively for the high volume production and testing of high quality Winchester disc drives.

Seagate tests every part and every assembly at every stage. This includes testing of every motor, metal part, disc cartridge, head assembly and component, active or passive. Final cartridge drive assembly is conducted within a controlled Class 100 environment. Continuing tests for particulate matter and other potential contaminants assure a clean environment.

All functional parameters on every drive are verified with extensive marginalizing testing. A proprietary data acquisition system records and reports any drive not meeting specifications. Faulty drives are repaired and recycled through the complete test system again.

The "105% Seagate Guarantee"

Under written contract, any Seagate disc drive protected under the "105% Seagate Guarantee" that fails an incoming inspection may be returned for an additional 5% credit. After Seagate receives, repairs and returns the drive, the credit is automatically issued.

Backing the guarantee is a complete incoming test program for the receiving department of qualified OEMs. The program includes a drive test system, on-site training for your people, a "gold standard" reference drive, and certification every ninety days.

The "105% Seagate Guarantee" is available, under written contract, to any volume purchaser of Seagate disc drives. To qualify, the customer must purchase 500 drives or more for U.S. delivery, and install Seagate's incoming test program.

Specifications

Capacity

Unformatted

Per Drive	6.38 Megabytes
Per Surface	3.19 Megabytes
Per Track	10416 Bytes

Formatted (as shipped from Seagate)

Per Drive	5.0 Megabytes
Per Surface	2.5 Megabytes
Per Track	8192 Bytes
Per Sector	256 Bytes
Sectors Per Track	32
Transfer Rate	5.0 MBits per second

Access Time

Track-to-Track	3 ms
Average	85 ms (inc. settling)
Maximum	205 ms (inc. settling)
Settling Time	15 ms
Latency (average)	8.33 ms

Error Rates

Soft read errors	1 per 10 ¹⁰ bits read
Hard read errors*	1 per 10 ¹² bits read
Seek errors	1 per 10 ⁶ seeks

*Not recoverable within 16 re-tries

Functional

Rotational Speed	3600 RPM ± 1%
Recording Density	9074 BPI
Flux Density	9074 FCI
Track Density	345 TPI
Cylinders	306
Read/Write Heads	2

Reliability

MTBF	11,000 POH typical usage
PM	Not required
MTTR	30 minutes
Component Design Life	5 years
Cartridge Interchangeability:	(1 in 10,000)

Environmental Limits

Ambient Temperature	40° to 122°F (4° to 50°C)
Relative Humidity	8 to 80%
Maximum Wet Bulb	78°F (25.5°C) non-condensing

Heat Dissipation

25 watts typical (85 BTU-HR)
29 watts maximum

Power Requirements

DC Power only
+12 VDC ± 10% starting (±5% recording)
3.7 amps max during motor start
(1.8 amps running)
+5 VDC ± 5%
1.0 amp maximum

Mechanical Drive

Height	3.25 inches (8.25 cm)
Width	5.75 inches (14.6 cm)
Depth	8.00 inches (20.32 cm)
Weight	5.30 pounds (2.4 kg)

Cartridge

Height	0.75 inches (1.9 cm)
Width	5.39 inches (13.7 cm)
Depth	5.55 inches (14.1 cm)
Weight	0.68 pounds (0.31 kg)

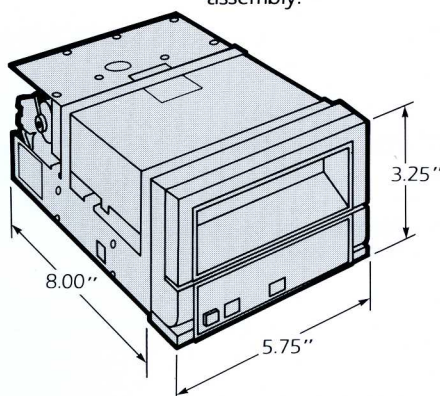

Functional Characteristics

General Operation

The ST706 disc drive consists of read/write and control electronics, two read/write heads, track positioning actuator, and air filtration system. The components perform the following functions:

1. Interpret and generate control signals
2. Position the heads over the desired track
3. Read and write data
4. Provide a contamination-free environment

Read/Write and Control Electronics

Electronics are packaged on two printed circuit boards. The primary board to which power, control and data signals are connected includes these circuits:

1. Index detection
2. Microcomputer controlled head positioning
3. Read/write
4. Drive up to speed
5. Head select
6. Fault detection
7. Cartridge interchange logic
8. Stepper motor drive
9. Drive select
10. Track zero detector
11. Automatic calibration

The second PCB, mounted to the baseplate under the primary board, derives its power from the primary board and provides power and speed control to the spindle drive motor.

Drive Mechanism

A brushless DC drive motor rotates the spindle at 3600 rpm. A direct drive spindle requires no belts or pulleys. The motor is thermally isolated from the baseplate to reduce heat. A shock mounted baseplate reduces vibration in the head disc assembly.

Air Filtration System

An integral recirculation air system with an absolute filter maintains a clean environment. The read/write chamber is automatically purged when a new cartridge is inserted.

Positioning Mechanism

Read/write heads are mounted on a ball bearing supported carriage. Heads are positioned by a band actuator connected to the stepper motor shaft.

Read/Write Heads and Disc Cartridges

The recording media consists of a high durability thin magnetic coating on a 130 mm diameter aluminum substrate. This coating material, together with the low load force-low mass Winchester-type flying heads, permits reliable contact start/stop operation.

Data on each of the two disc surfaces is read by one read/write head, each of which accesses 306 tracks.

The ST706 maintains five more interface lines than other Seagate drives:

Change cartridge is issued by the host. It initiates a power down sequence if Ready and Drive Select are active.

Cartridge changed is issued by the drive. It notifies the host when the operator has changed the cartridge. A latch is set when the operator removes the cartridge. It is reset by the transition from the drive selected to drive not selected.

Recalibrate is used when the prescribed error rate is reached. The head position calibration sequence is initiated to position the heads more accurately over the data. Ready must be active for recalibration to begin.

Cartridge write protected is issued by the drive when a write protected cartridge is inserted in the drive.

Radial index is issued by the drive to provide continuous index timing for the host.

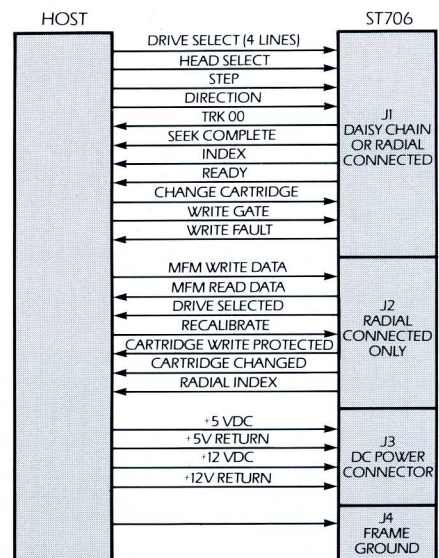

Seagate's Freedom Generation

Seagate's ST706 drive combines the reliability and data access speed of Winchester technology with the portability of a 5¼-inch removable cartridge. You can use the disc cartridge in applications calling for removable data. Or use it with Seagate ST400 Series fixed discs for I/O, program loading and backup.

The ST706 offers a capacity of 6.38 megabytes unformatted, 5.0 megabytes formatted—the same capacity as the Seagate ST406 and ST506.

Manganese-zinc heads and an advanced stepper motor design enable high track density. The improved head design allows increased bit packing, utilizing more of the disc surface and double the number of tracks over the original micro-Winchester.

Better Than Other Removable Media

Five megabytes per cartridge give you more capacity than floppy or minifloppy media. Random access delivers faster speed than tape. And Winchester technology guarantees better data integrity and systems reliability than floppy or tape. It is ideal for portable computers.

The ST706 cartridge drive can produce a complete mirror image backup of an ST406 disc in less than two minutes. And the soft error rate is much better than tape backup. In addition, you can share the same controller as the ST400 Series fixed disc drive.

The **MicroDisc** cartridge utilized by the ST706 has been accepted as the industry standard for 5¼-inch removable cartridge disc drives.

Easy integration. Physical integration, controller design and software implementation are far easier than tape or floppy for backup. The ST706 is compatible in form factor, interfacing and power requirements with our ST506 and ST400 Series drives. Commonality in transfer rate, access method, and command sets allow use of one simple, compact controller. Automatic copy, flagging of bad sectors, error correction, and other value-added features can be integrated into the controller design at low cost.

Winchester Reliability

The ST706 brings Winchester reliability to removable data storage. Under typical usage, MTBF is rated the same as Seagate's fixed disc models—11,000 power on hours. No preventive maintenance is required.

This high reliability results from maintaining the protected read/write environment of Winchester technology in a sealed cartridge. When the **MicroDisc** is inserted into the drive, an automatic purge cycle cleans the read/write chamber. Automatic head calibration is performed, as needed, within one second.

A fixed guide together with a magnetic chuck and a three-point centering mechanism provide simple, reliable cartridge loading. A proprietary "no bounce" locking action assures positive positioning of the cartridge disc before operation. This positive positioning also assures cartridge interchangeability.

Automatic head retraction with cartridge removal and highly durable disc surfaces prevent media damage, even when the cartridge is removed under power off conditions. This also provides protection to the stored data when portability is required.

The ST706 uses proven Seagate positioning and drive mechanisms. High reliability is assured through the use of a proven metal band actuator, stepper head positioner, and direct drive brushless DC motor. The dynamically balanced motor/spindle assembly and a shock mounted baseplate reduce vibration.

The low load force and mass of Winchester flying heads and the high durability thin magnetic coated media on a 130 mm diameter aluminum substrate provide reliable contact start/stop operation. Each disc surface is read by a dedicated read/write head.

Fully enclosed discs and the read/write heads are protected by an integral recirculation air system with an absolute filter. Greater off-track margin is possible due to an extremely low temperature rise. Stepper and spindle motors are thermally isolated. Heat dissipation is rated at 25 watts, typical.

Only DC voltages (+12 and +5 VDC) are required. All electronics are packaged on two printed circuit boards. The boards are conveniently mounted to allow quick access and easy field repair.

The ST706 cartridge drive carries a one year warranty.

Winchester Performance

An advanced stepper motor, metal band actuator and the onboard micro-computer's buffered seek offer an average access time, including settling, of 85 milliseconds. The maximum access time is 205 milliseconds. Track-to-track access is three milliseconds.

Extra Assurance of Quality

Seagate Technology manufactures, tests and ships disc drives of consistently high quality. The Seagate manufacturing facilities have been designed exclusively for the high volume production and testing of high quality Winchester disc drives.

Seagate tests every part and every assembly at every stage. This includes testing of every motor, metal part, disc cartridge, head assembly and component, active or passive. Final cartridge drive assembly is conducted within a controlled Class 100 environment. Continuing tests for particulate matter and other potential contaminants assure a clean environment.

All functional parameters on every drive are verified with extensive marginalized testing. A proprietary data acquisition system records and reports any drive not meeting specifications. Faulty drives are repaired and recycled through the complete test system again.

The "105% Seagate Guarantee"

Under written contract, any Seagate disc drive protected under the "105% Seagate Guarantee" that fails an incoming inspection may be returned for an additional 5% credit. After Seagate receives, repairs and returns the drive, the credit is automatically issued.

Backing the guarantee is a complete incoming test program for the receiving department of qualified OEMs. The program includes a drive test system, on-site training for your people, a "gold standard" reference drive, and certification every ninety days.

The "105% Seagate Guarantee" is available, under written contract, to any volume purchaser of Seagate disc drives. To qualify, the customer must purchase 500 drives or more for U.S. delivery, and install Seagate's incoming test program.



Seagate Technology

360 El Pueblo Road, Scotts Valley, California 95066 Telephone (408) 438-6550 TELEX 172114 SCVL

Regional Sales Offices:

12 Grove Street, Hopkinton, Massachusetts 01748 Telephone (617) 435-6961

4000 McArthur Boulevard, Suite 3000, Newport Beach, California 92660 Telephone (714) 851-9964

888 South Greenville Avenue, Suite 100, Richardson, Texas 75081 Telephone (214) 783-6711

Authorized U.S. Distributor: Arrow Electronics

European Sales Office:

Kreillerstrasse 21, 8000 Munich 80, West Germany Telephone 89 43 13 900 TELEX 5 213 379

Japan:

Teac Corporation, 3-7-3 Naka-cho, Musashino, Tokyo Telephone (0422) 53-1111 TELEX 2822451