

SAGUARO

*Saguaro* **OVERVIEW** October 1996

SG 1.0/2.1

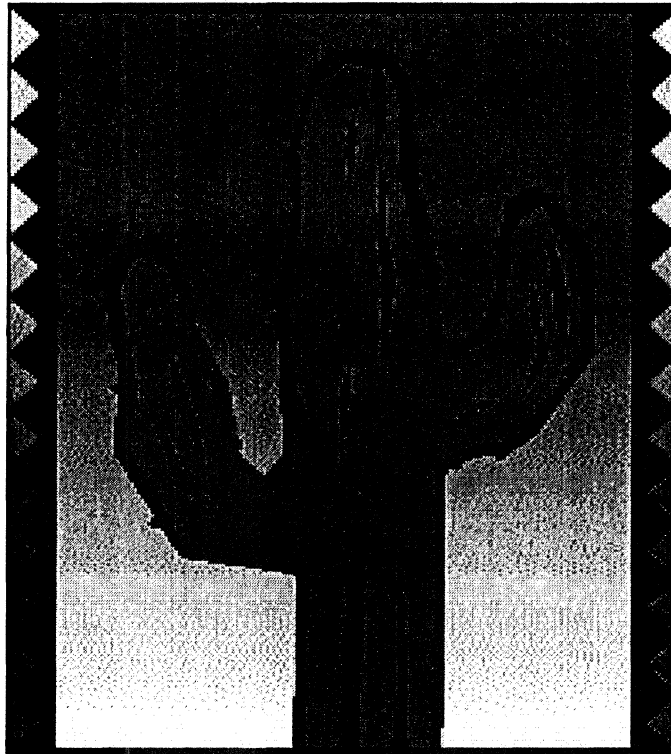

**SAGUARO**

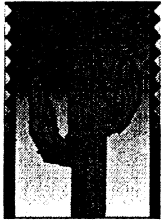

SAGUARO

# *Saguaro* OVERVIEW October 1996

SG 1.0/2.1

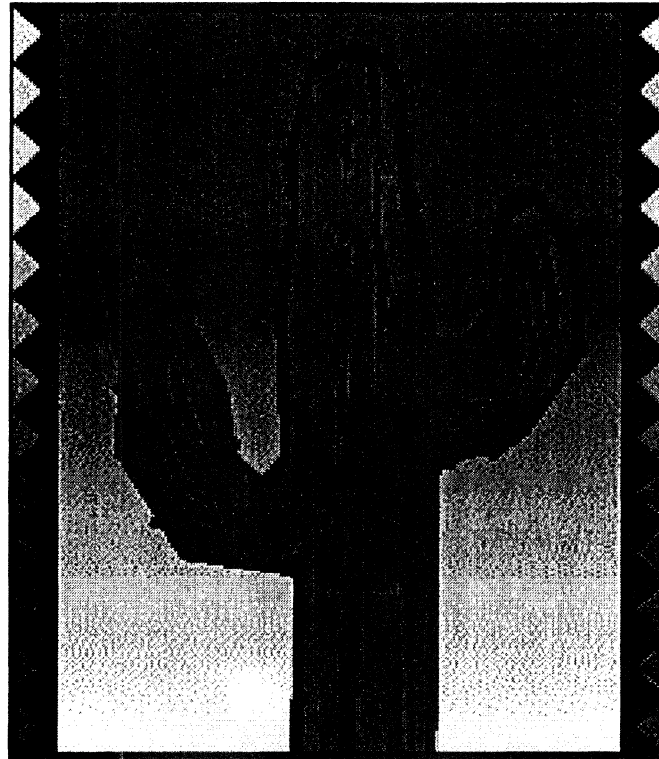

# SAGUARO

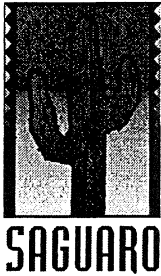

# Saguaro Agenda -- Monday Oct. 28

SG 1.0/2.1

## ***USA SESSION***

<u><i>Time</i></u>	<u><i>Section</i></u>	<u><i>Presenter</i></u>
◆ 7:00-7:30 (1)	Overview	Charlie Helkenn
◆ 7:30-8:15 (2)	Mechanical	Manchi Colah
◆ 8:15-9:15 (3)	Heads & Media	Saeed Foudeh, Francis Crimi
◆ 9:15-9:30 x	Break	
◆ 9:30-11:00 (4)	Firmware	TS Lee



SAGUARO

# Saguaro Agenda -- Tuesday Oct. 29

## ***USA SESSION***

*SG 1.0/2.1*

<u><i>Time</i></u>	<u><i>Section</i></u>	<u><i>Presenter</i></u>
◆ 7:00-7:45	(5) PCB & Rd/Wr	Minh Pham
◆ 7:45-8:30	(6) Servo	Joe Lillig, Joe Chen
◆ 8:30-9:00	(7) DVT /DMT	Seyed Saatchi
◆ 9:00-9:15	x Break	
◆ 9:15-10:00	(8) Test Process	Phillip Nguyen
◆ 10:00-10:45	(9) FA technique	Dave Rutherford
◆ 10:45-11:00	(10) Wrapup	Charlie Helkenn & Mike Bolt



SAGUARO

# Lab Training

*SG 1.0/2.1*

- ◆ 1:00-3:00 Hands-on Dave Rutherford
- ◆ Where: Saguaro Lab, Building 4 downstairs

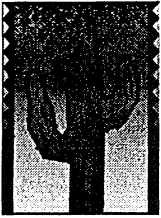

SAGUARO

# Saguaro Agenda -- Monday Oct. 28

## **APAC SESSION**

SG 1.0/2.1

<u>Time</u>	<u>Section</u>	<u>Presenter</u>
◆ 16:00-16:30	(1) Program Overview	Charlie Helkenn
◆ 16:30-17:15	(2) Mechanical	Manchi Colah
◆ 17:15-18:15	(3) Heads & Media	Saeed Foudeh, Francis Crimi
◆ 18:15-18:30	x Break	
◆ 18:30-20:00	(4) Firmware	TS Lee

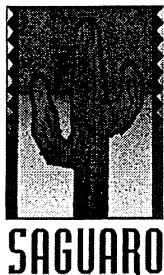

# Saguaro Agenda -- Tuesday Oct. 29

## ***APAC SESSION***

*SG 1.0/2.1*

<u><i>Time</i></u>	<u><i>Section</i></u>	<u><i>Presenter</i></u>
◆ 16:00-16:45 (5)	PCB & Rd/Wr	Minh Pham
◆ 16:45-17:30 (6)	Servo	Joe Lillig, Joe Chen
◆ 17:30-18:00 (7)	DVT /DMT	Seyed Saatchi
◆ 18:00-18:15 x	Break	
◆ 18:15-19:00 (8)	Test Process	Phillip Nguyen
◆ 19:00-19:45 (9)	FA technique	Dave Rutherford
◆ 19:45:20:00 (10)	Wrapup	Charlie Helkenn & Mike Bolt



SAGUARO

# Low Cost Innovation

## *What is improved with Saguaro Design?*

SG 1.0/2.1

### Trailblazer

- Stamped Sheet Metal Base
- Separate Sheet Metal Rails
- Pre-amp separate from E-Block
- Machined Stamped E-Block
- 128K Buffer
- Flex Circuit wrapped around base



### Saguaro

- Stamped Steel Base
- Integrated Steel Rails
- Pre-amp mounted on E-Block arm
- Encapsulated E-Block
- 64K Buffer for cost savings
- Shorter Flex circuit integrated into base

## How Will Saguaro Perform?

<b>Acoustics</b>	◆ Steel base insulates sound better and dual top cover continues Trailblazer leading idle and seeking acoustics.
<b>Vibration</b>	◆ Ribbed based and tied top cover provide stronger design to support higher vibration spec. (1G @ 5-300Hz).
<b>Shock Performance</b>	◆ Improvements over Trailblazer through HDA to support new 150 G @ 3ms non-op shock spec.
<b>Benchmarks</b>	◆ Initial firmware baselining with 64K buffer proves performance greater than Trailblazer.





**SAGUARO**

# Product Specifications

\* = Targets

*SG 1.0/2.1*

	<b>Saguaro</b>	<b>Fireball-TM</b>	<b>Trailblazer</b>
Capacity (GB)	1.0/2.1	1.0/1.2/2.1/2.5/3.2/3.8	420/850 MB
Interface	AT	AT/SCSI	AT/SCSI
Heads	TF-Proximity	MR	Mig
Seek Time (ms)	12	12/10/10	14
RPM	4500	4500	4500
Buffer (KB)	64	128	128
Data Rate (Mb/sec)	101	85	54
Throughput (WMarks)	830 +*	900 *	700+
Acoustics-Idle (dBA)	30 *	34	30
Operational Vibration	5-300 @ 1G	5-300 @ 1G	5-250 @ 1G
Power - Idle (W)	3.7	3.8	3.3
- R/W (W)	5.2	6.0	4.5
Volume Availability	Dec. '96	May '96	Apr. '95

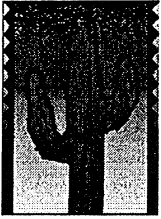

SAGUARO

# Program Schedule

SG 1.0/2.1

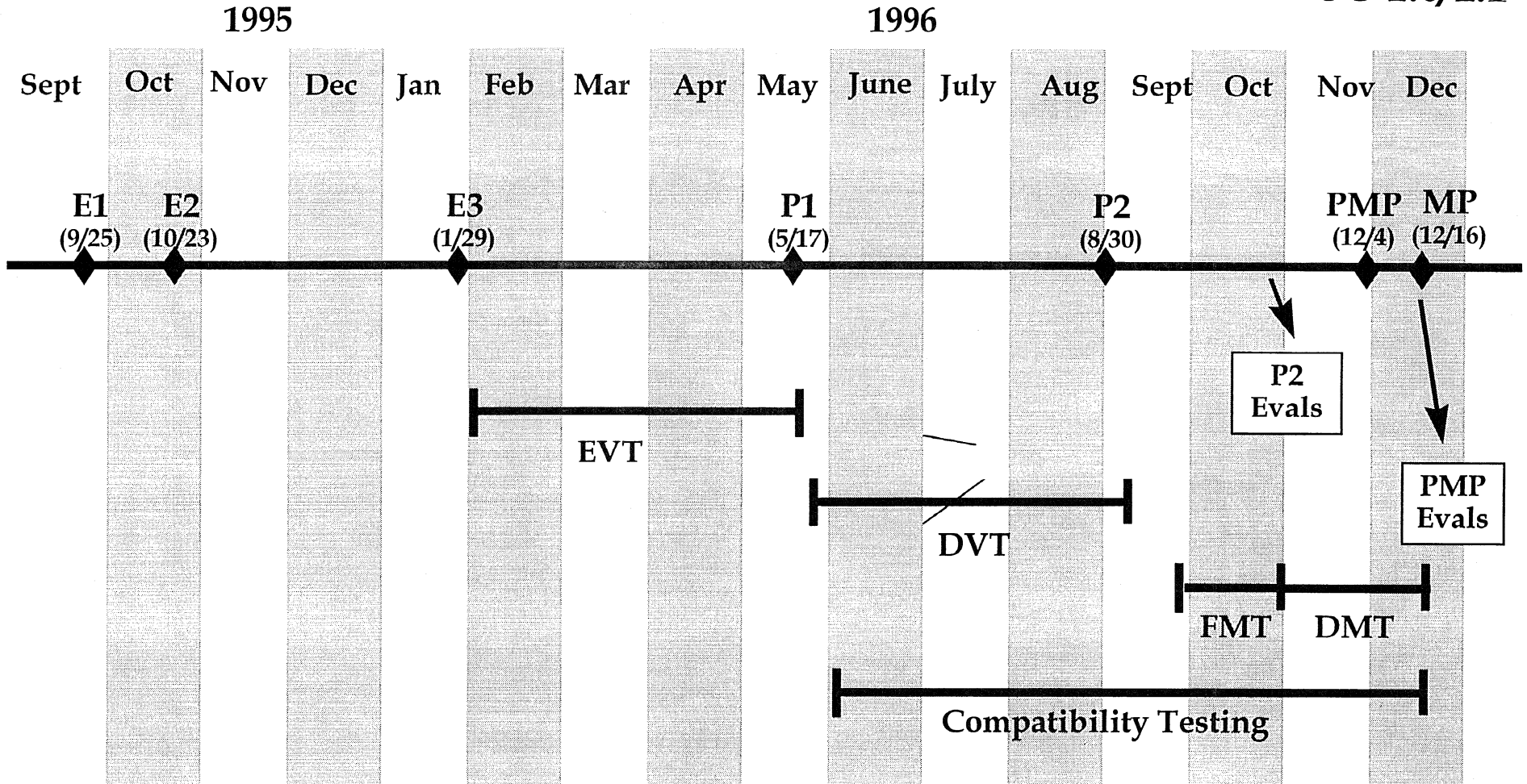

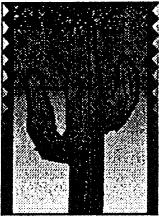

# Program Schedule

SAGUARO

SG 1.0/2.1

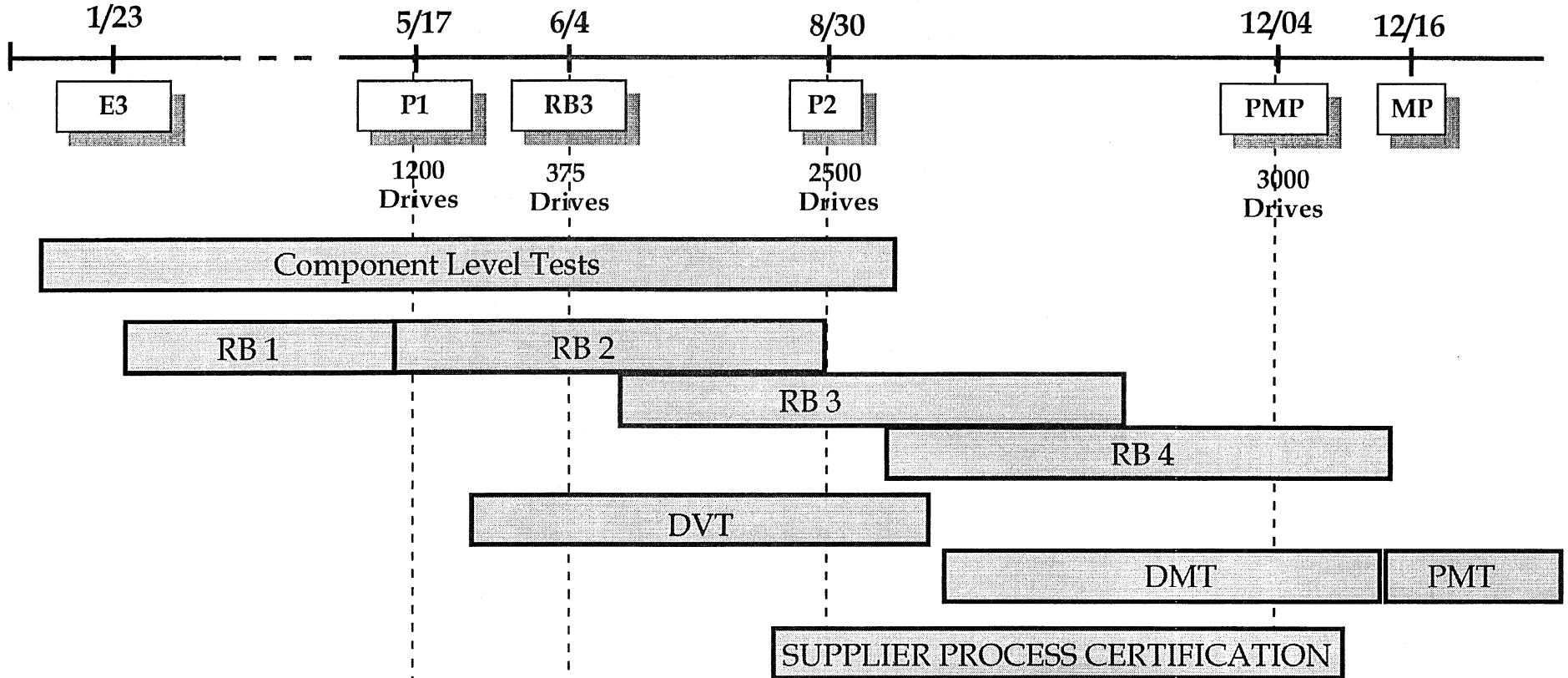

Update

- P2 build completed successfully with 82% self scan yields
- DMT test plans in place - testing to begin in early October

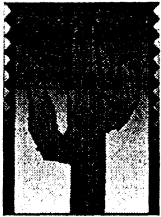

**SAGUARO**

# *Saguaro* MECHANICAL Oct -96

*SG 1.0/2.1*

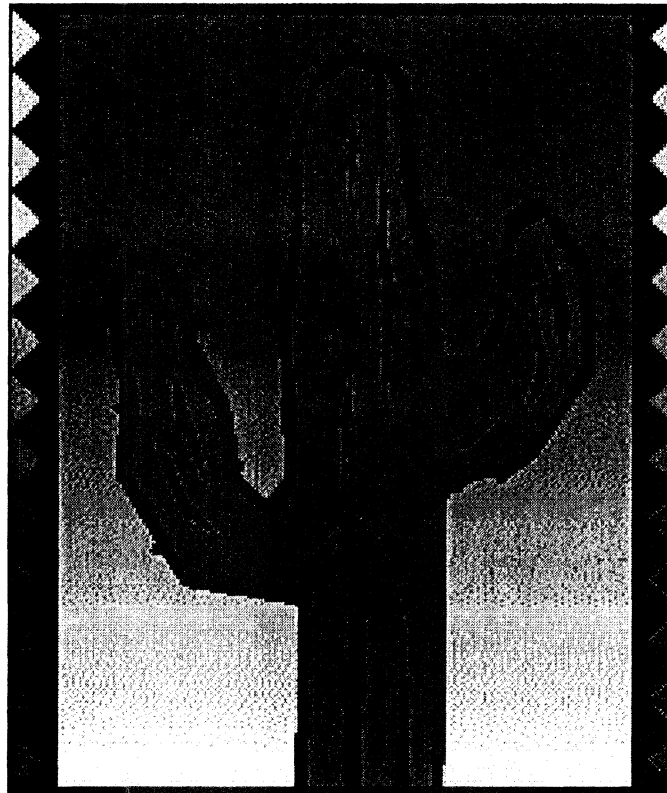

# **SAGUARO**

10-24-96

Saguaro Training Manual  
Section 2 MECHANICAL

Page 1

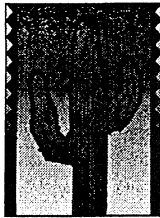

SAGUARO

# SPECIFICATIONS

SG 1.0/2.1

	<u><i>1 Disk</i></u>	<u><i>2 Disk</i></u>
◆ CAPACITY	1080 MB	2160 MB
◆ TRACKS	5650 per inch	
◆ FORM FACTOR	1" high	
◆ SEEK TIME	12 msec	
◆ RPM	4500	

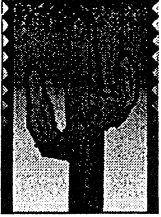

SAGUARO

# SPECIFICATIONS, Cont

*SG 1.0/2.1*

- ◆ OPERATIONAL SHOCK 10g 11msec, 18g 3msec
- ◆ NON-OP SHOCK 70g 3msec, 150g 3msec
- ◆ OP VIBRATION 1g 5-300 Hz p-p
- ◆ NON-OP VIBRATION 2g 5-500 Hz P-P



SAGUARO

# NON-OP ROTATIONAL SHOCK, Unlatching

SG 1.0/2.1

	<u>SAGUARO</u>	<u>TRBL</u>
◆ Airlock	11K rad/sec <sup>2</sup> , 2.6msec	3.5K rad/sec <sup>2</sup> , 3.3msec
◆ Actuator	>39K rad/sec <sup>2</sup> , 0.8msec	39K rad/sec <sup>2</sup> , 0.8msec



SAGUARO

# ACOUSTIC SPECIFICATIONS

SG 1.0/2.1

## SAGUARO

## TRBL

### ◆ SOUND POWER

– Idle	3.5B, 3.8B (+3)	3.5 Bel
– Seeking	4.0B, 4.4B (+3)	4.2B

### ◆ SOUND PRESSURE

– Idle	<30dbA, 32dbA (+3)	30dbA
– Seeking	35dbA, 38dbA (+3)	37dbA





SAGUARO

# Saguaro Exploded View

SG 1.0/2.1

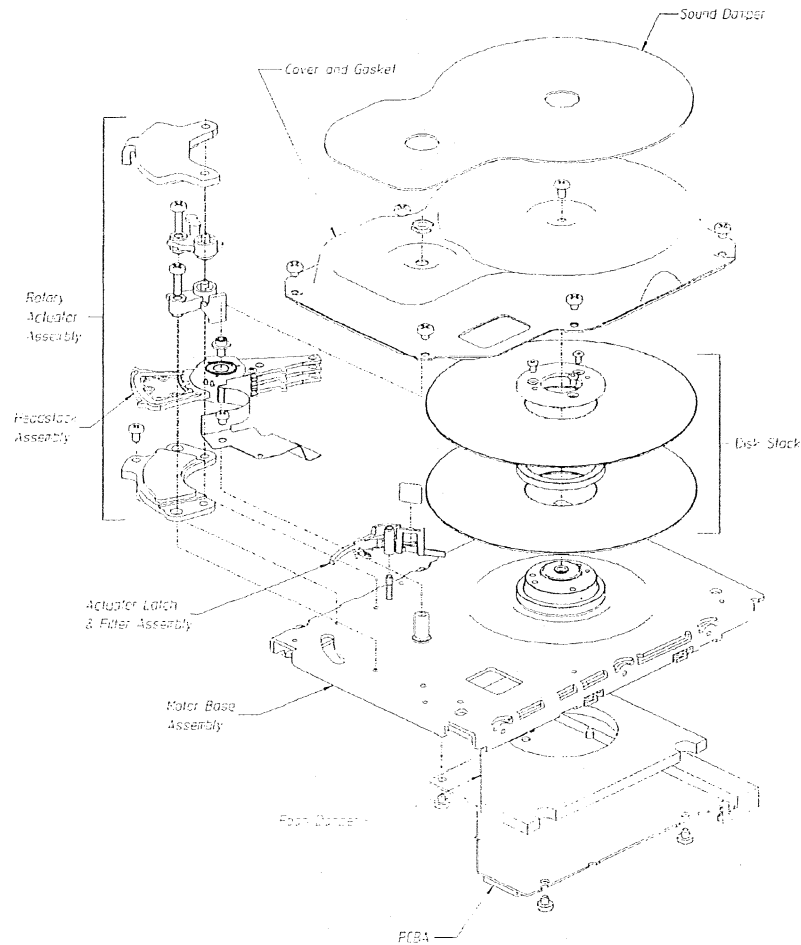

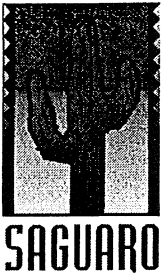

# Disk Clamp

SG 1.0/2.1

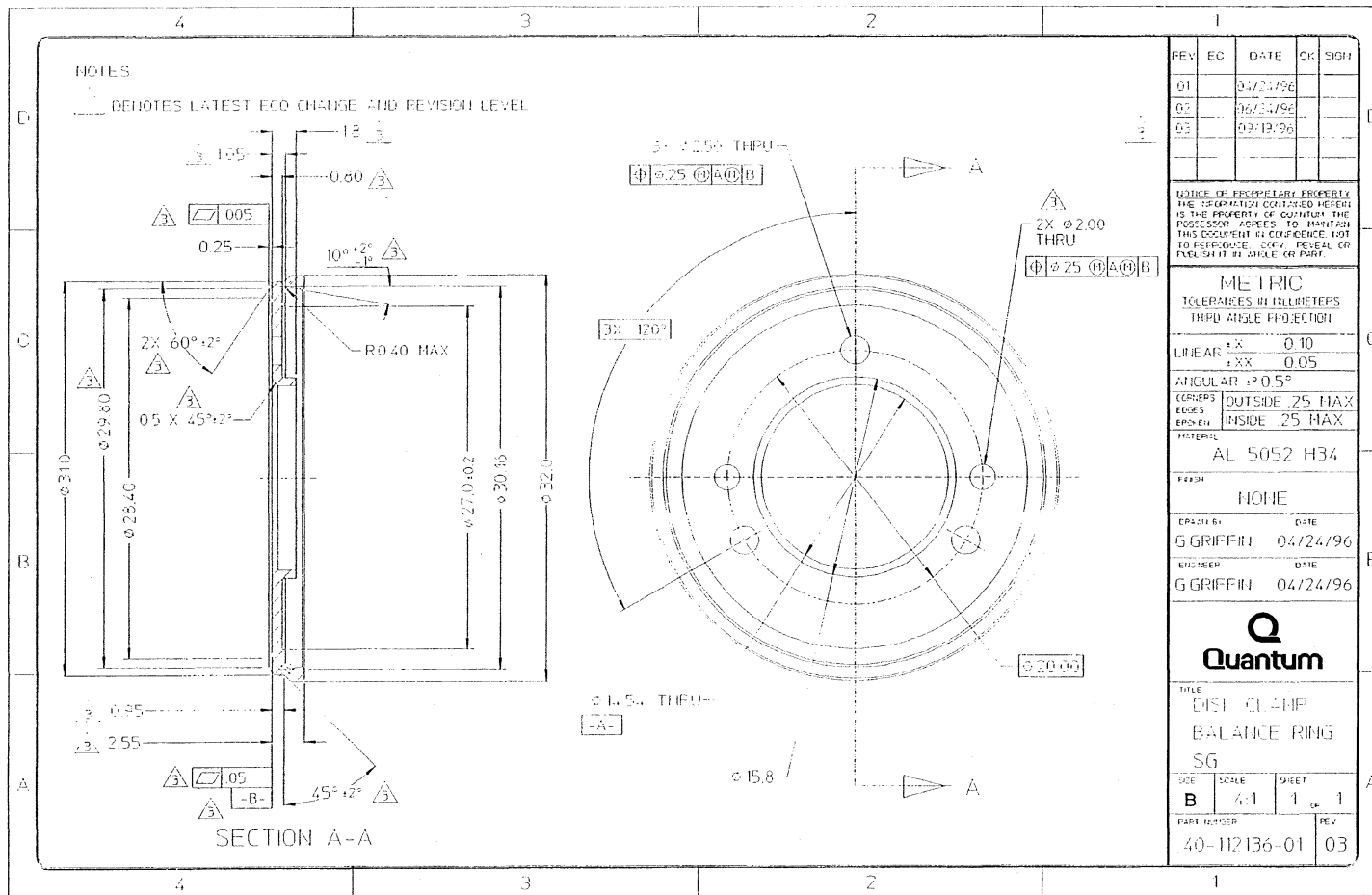

REV	EC	DATE	OK	SIGN
01		04/24/96		
02		06/24/96		
03		09/13/96		

NOTICE OF PROPRIETARY PROPERTY  
 THE INFORMATION CONTAINED HEREIN  
 IS THE PROPERTY OF QUANTUM. THE  
 POSSESSOR AGREES TO INDEMNIFY  
 THIS COMPANY IN CONFIDENCE NOT  
 TO REPRODUCE, COPY, REVEAL OR  
 EXHIBIT IN WHOLE OR PART.

METRIC  
 DIMENSIONS IN MILLIMETERS  
 THIRD ANGLE PROJECTION  
 LINEAR: ±X 0.10  
 ±XX 0.05  
 ANGULAR: ±0.5°  
 CORNERS: OUTSIDE .25 MAX  
 EDGES: INSIDE .25 MAX  
 MATERIAL: AL 5052 H34

FINISH: NONE  
 DRAFTER: G GRIFFIN 04/24/96  
 ENGINEER: G GRIFFIN 04/24/96

**Quantum**

TITLE: DISK CLAMP  
 BALANCE RING  
 SG

SIZE: B SCALE: 4:1 SHEET: 1 OF 1  
 PART NUMBER: 40-112136-01 REV: 03

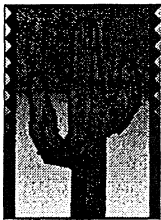

SAGUARO

# Vibration Levels (g)

SG 1.0/2.1

<u><i>Drive Type</i></u>	<u><i>Average</i></u>	<u><i>Max</i></u>	<u><i>Biased?</i></u>
◆ Trb, 2D	0.066	0.163	No
◆ Trb, 1D	0.06	0.134	No
◆ Sg, P1, 2D	0.054	0.138	No
◆ Sg, P1, 1D	0.062	0.138	No
◆ Sg, P1, 2D, Biased	0.039	0.086	Yes
◆ Sg, P2, 2D, Biased	0.019	0.052	Yes
◆ Sg, P2, 1D, Biased	0.018	0.043	Yes

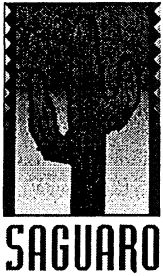

# Summary of Drive Vibration

SG 1.0/2.1

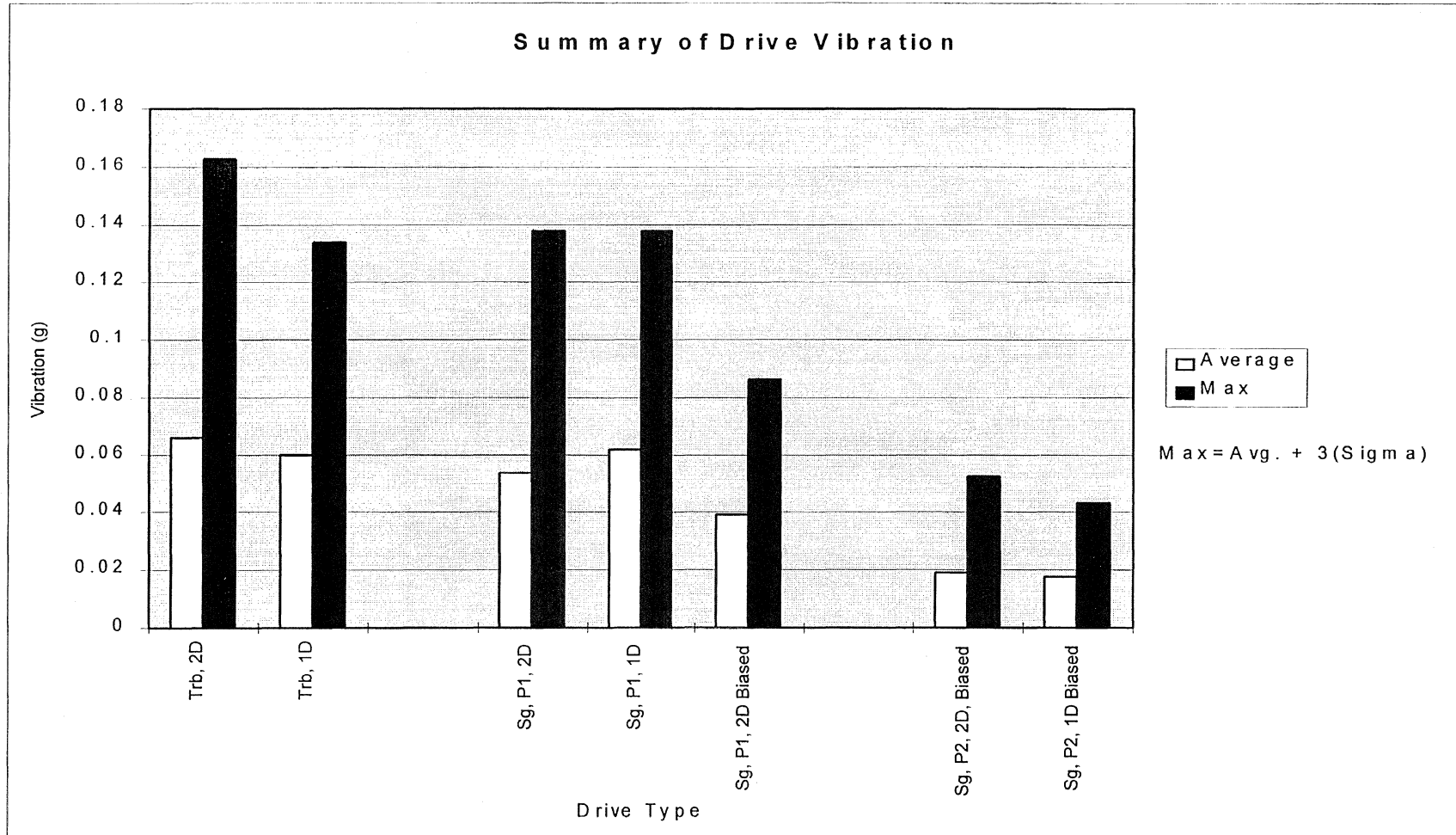

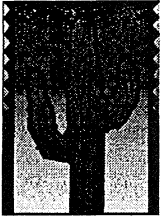

SAGUARO

# Saguaro Airlock

*SG 1.0/2.1*

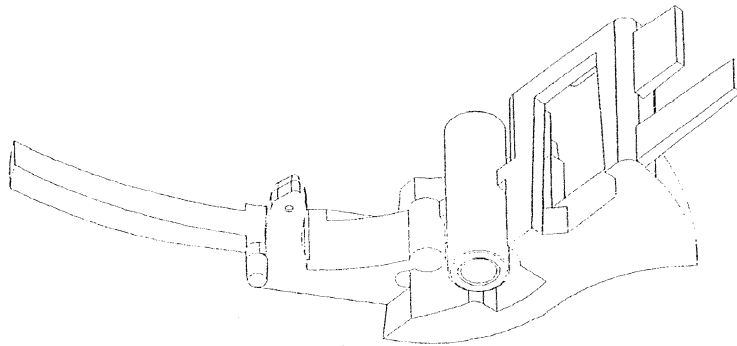
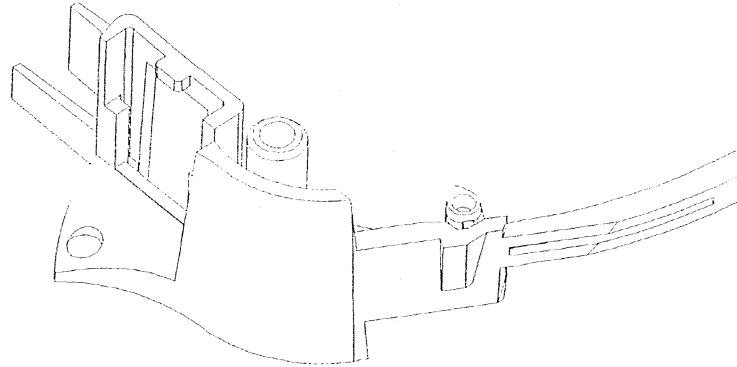



**SAGUARO**

# Saguaro Airlock

*SG 1.0/2.1*

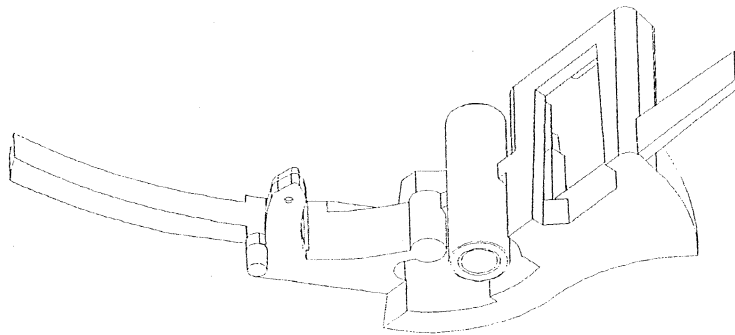
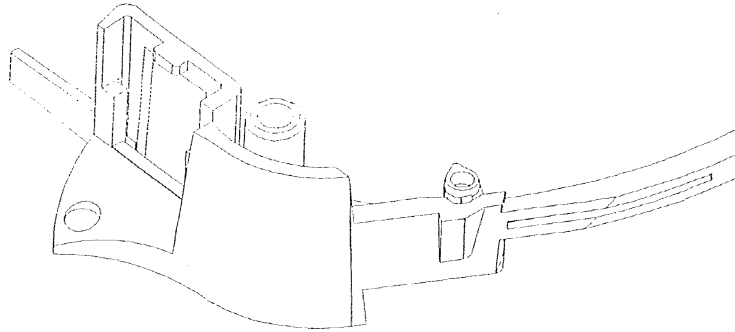



**SAGUARO**

# HEADSTACK ASSEMBLY

---

*SG 1.0/2.1*

- ◆ FLEX GUIDE IS INTEGRAL WITH ENCAPSULATION.
- ◆ 50 % SLIDER.
- ◆ THIN FILM HEAD.
- ◆ FLYING HEIGHT 1 inch.
- ◆ PRE-AMP ON ACTUATOR, CLOSER TO HEADS.

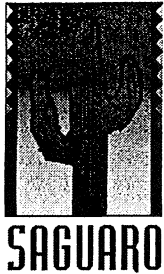

# MAIN IMPROVEMENTS OVER TRBL

*SG 1.0/2.1*

- ◆ FAR LESS AIRLOCK SUSCEPTIBILITY TO ROTATIONAL SHOCK.
- ◆ z height CLEARANCE FROM 0.37 mm TO 0.57 mm.
- ◆ SHORTER & STIFFER FLEX.
- ◆ FLEX GUIDE IS INTEGRAL WITH ENCAPSULATION.
- ◆ SPINDLE MOTOR TIED TO STEEL COVER.





SAGUARO

# MAIN IMPROVEMENTS OVER TRBL

*SG 1.0/2.1*

- ◆ IMPROVED & MORE RIGID ACTUATOR - STAMPED ARMS, PLASTIC ENCAPSULATION, INCLUDES PRE-AMP.
- ◆ BETTER TRACK LAYOUT TO GIVE MORE MARGIN FROM LANDING ZONE.
- ◆ ADDED UPPER MAGNET - BETTER ACOUSTICS, EXCELLENT LINEARITY IN TORQUE CURVE, BETTER SEEK TIME (14 -> 12 msec)
- ◆ RAILS ARE INTEGRAL WITH STEEL BASE PLATE.



SAGUARO

*Saguaro* **HEADS & MEDIA** 10/96



*SG 1.0/2.1*

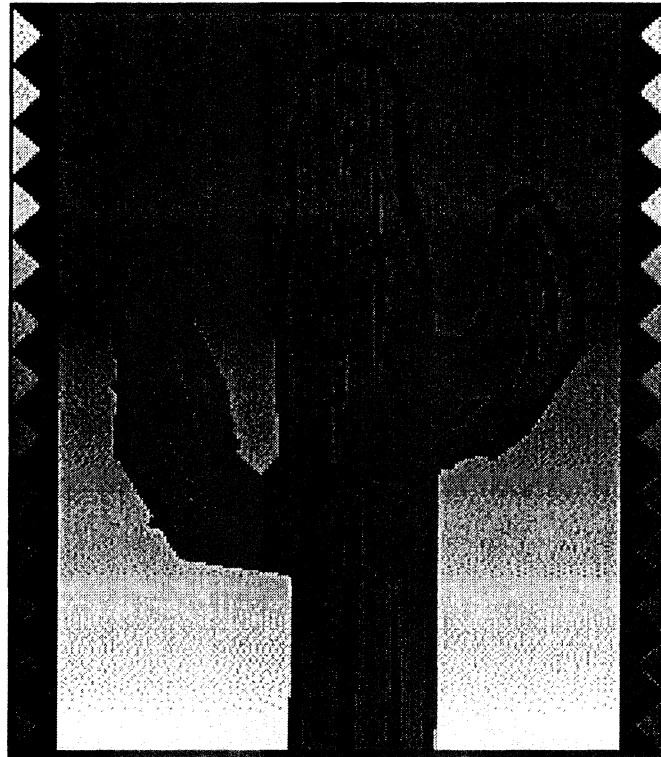

**SAGUARO**

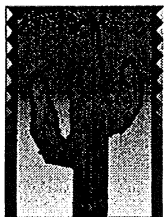

SAGUARO

# WHY PROXIMITY RECORDING?

*SG 1.0/2.1*

- ◆ Previous Inductive Thin Film programs used flying heads which were designed to fly above the glide height (highest points) of the recording disk.
- ◆ Flying closer to the recording disk allows for higher storage densities.
- ◆ In order to meet recording density of 1080 MB/disk using less expensive Inductive heads, the flying height was reduced.
- ◆ A Proximity recording head/disk interface which is properly designed can meet the reliability requirements established by Flying Heads.

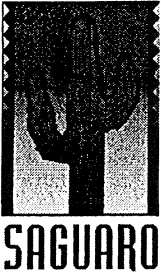

# PROXIMITY RECORDING OVERVIEW

*SG 1.0/2.1*

- ◆ **GENERAL DEFINITION OF PROXIMITY RECORDING: WHEN THE HEAD IS DESIGNED TO FLY BELOW THE GLIDE HEIGHT (HIGHEST POINTS) OF THE MEDIA.**
  - THIS IMPLIES THAT THERE ARE INTERMITTENT CONTACTS BETWEEN THE HEAD AND THE DISK.
  
- ◆ **PROXIMITY RECORDING INTERFACE OBJECTIVES:**
  - LOW CONTAMINATION (IONIC AND PARTICULATE)
  - CONTROLLED MEDIA ROUGHNESS
  - DURABLE CARBON PROTECTIVE LAYER
  - DURABLE YET THIN LUBRICANT LAYER

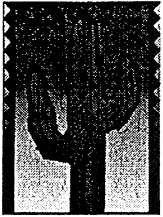

**SAGUARO**

# Drive Requirements

*SG 1.0/2.1*

- ◆ Max KFCI: 132
- ◆ TPI: 5650
- ◆ Mb/in<sup>2</sup>: 702
- ◆ Channel: 16/17 PRML
- ◆ RPM: 4500

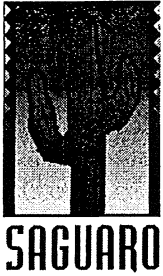

# Head Design

*SG 1.0/2.1*

- ◆ 50% Thin Film Inductive: 42T, 4 Layer - Center Transducer
- ◆ Tri-NPAB: Negative Pressure Air Bearing
- ◆ Flying Height: ~0.8 in
- ◆ Track Width: 3.7 +/- 0.4 um, Track Trimmed
- ◆ Gap Length: 0.22 +/- 0.022 um
- ◆ Load Force: 3.5 +/- 0.4 grams
- ◆ Z-Height: 0.035 inch
- ◆ Suspension: T850, 2.5mil Thru-Etch Loadbeam, Low Profile

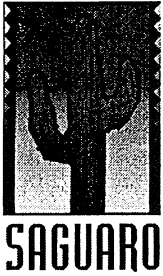

# Media Design

*SG 1.0/2.1*

- ◆ Substrate Material
  - Aluminum
- ◆ Sublayer Material
  - Ni-P
- ◆ Magnetic Layer
  - Material                    Co,Cr,x,x,x,
  - Coercivity (Oe)            2200
  - Remanence (G-um)        220

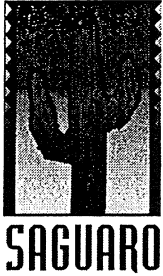

# Media Design, Cont

*SG 1.0/2.1*

- ◆ Texture Ra:
  - 30-60 Angstroms Data Zone
- ◆ Lubricant Material
  - PFPE Based
- ◆ Overcoat
  - Material            Nitrogen doped Carbon
  - Thickness        15-20 nm
- ◆ Glide Height
  - Data Zone        1.2in
  - Landing Zone    1.5 in





# Media Surface

*SG 1.0/2.1*

- ◆ Texture, Carbon and Lubricant are specially designed to sustain Proximity recording.

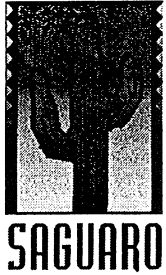

# DESIGN REQUIREMENTS

SG 1.0/2.1

## PROXIMITY ABS

- ◆ ABS must have flat FH across stroke in order to meet areal density requirements of 1080 MB/disk.
- ◆ ABS designs such as Read-Rite “TriPad” cannot yield constant flying height.
- ◆ Design for constant contact force across stroke.
- ◆ Reduced ABS tolerance sensitivities.
- ◆ Manufacturability.

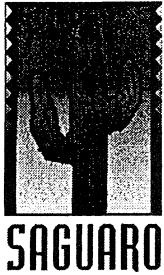

# PROXIMITY ABS APPROACH

## THE “TRI-NPAB”

SG 1.0/2.1

- ◆ Use a modified Negative Air Pressure Air Bearing (NPAB) design.
- ◆ Design utilizes short side “catamarans” and a center transducer device location.
- ◆ Head suppliers already have NPAB designs which have been modified into a center transducer “TRI-NPAB”.
- ◆ Process to make TRI-NPAB designs already in place at suppliers.

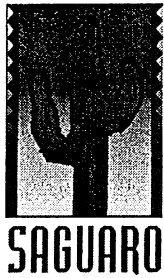

# BENIFITS OF THE “TRI-NPAB” APPROACH

*SG 1.0/2.1*

- ◆ Center transducer yields less sensitivity to HGA roll-related issues such as bonding location and suspension static attitude.
- ◆ Negative Pressure ABS allows flexibility to design desired flying height and contact force.



SAGUARO

# The HEAD



*SG 1.0/2.1*

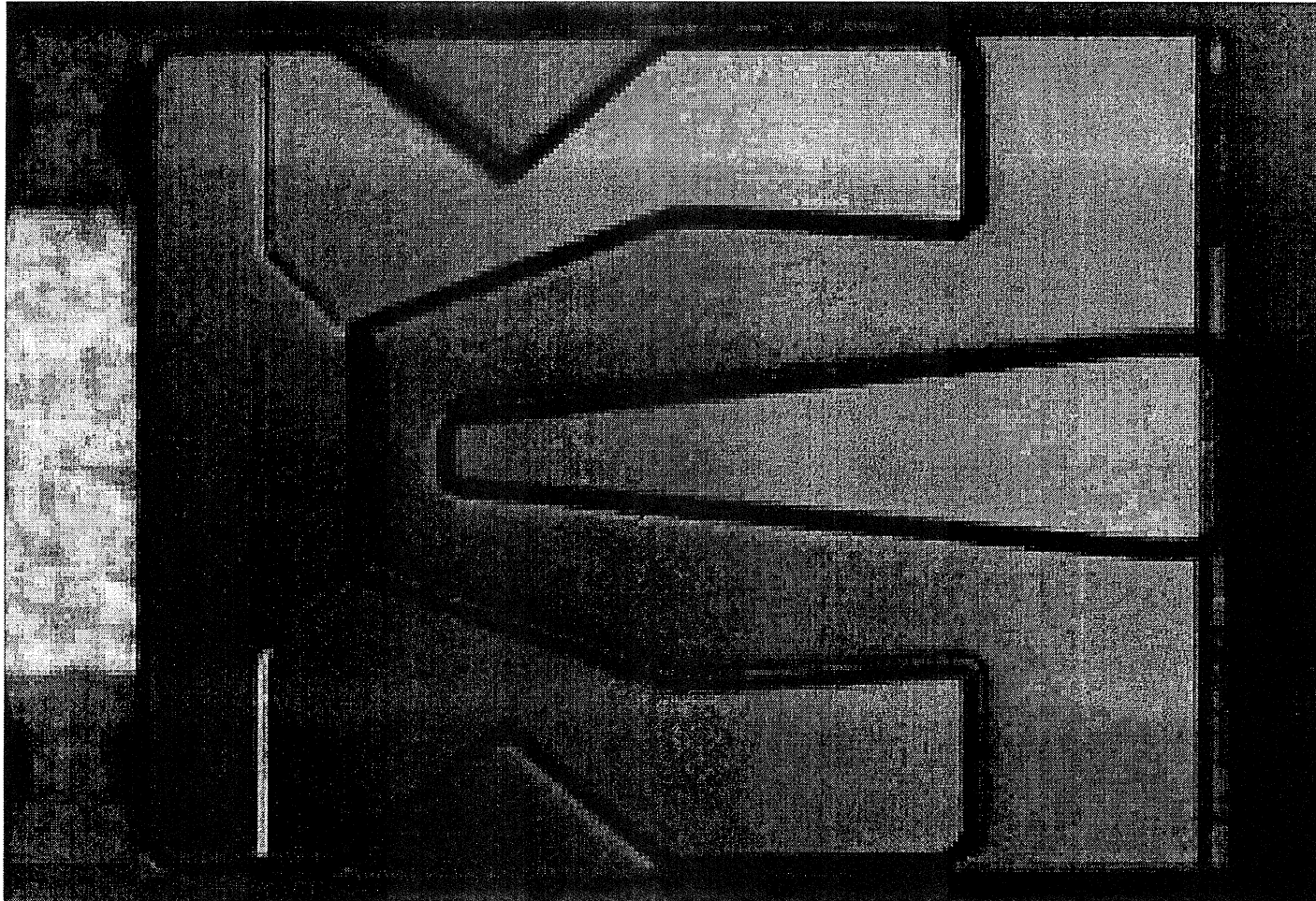

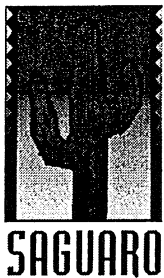

# Pressure Profile for Saguario Tri-NPAB

3-D Pressure Plot

SG 1.0/2.1

YAMAHA , skew=12.37 (dgrs), radial pos=19.08 (mm), rpm=4500

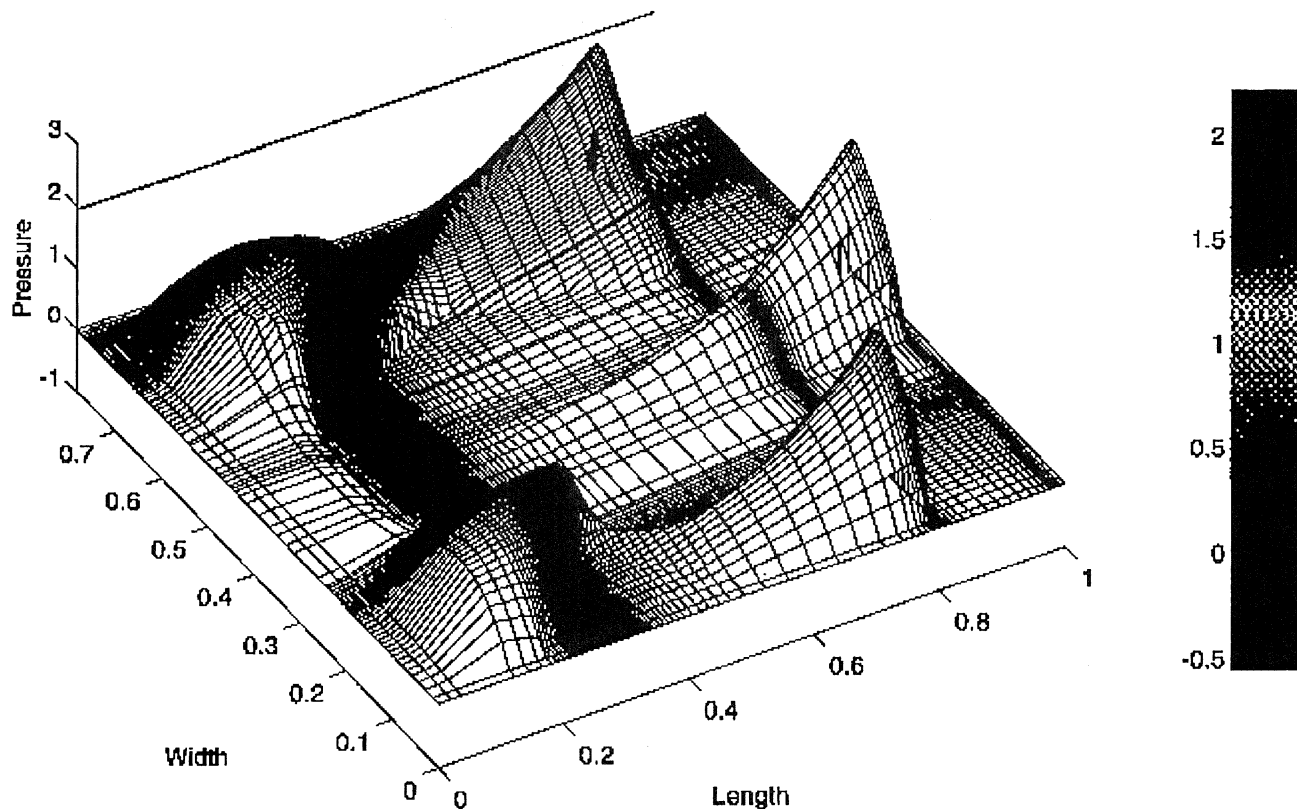



SAGUARO

# SUPPLIER LIST

SG 1.0/2.1

## ◆ HEADS:

- Yamaha: Tri-NPAB ABS
- Read-Rite: Tri-NPAB ABS
- AMC: Tri-NPAB ABS

## ◆ MEDIA:

- Fuji
- MCC
- HMT



**SAGUARO**

*Saguaro* **FIRMWARE** October 1996



*SG 1.0/2.1*

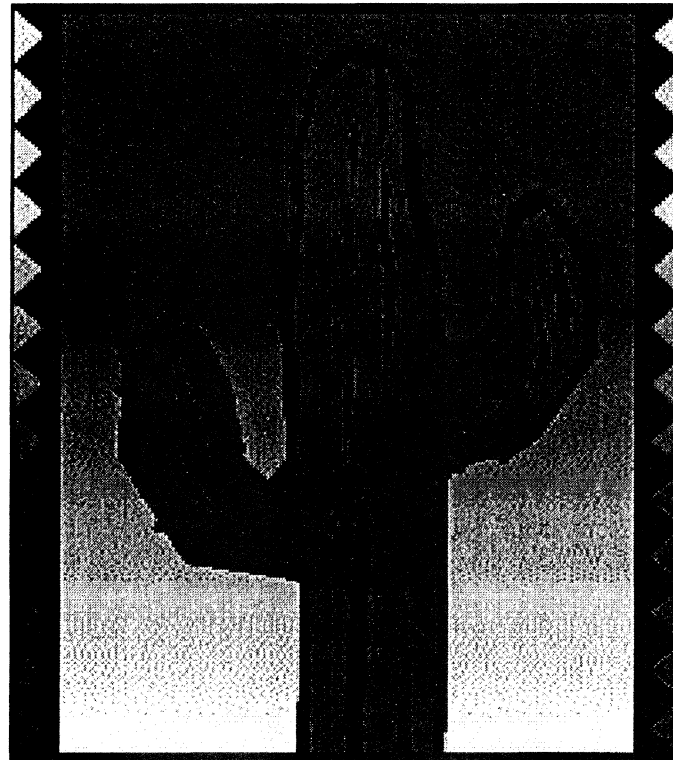

**SAGUARO**





SAGUARO

# Firmware History

SG 1.0/2.1

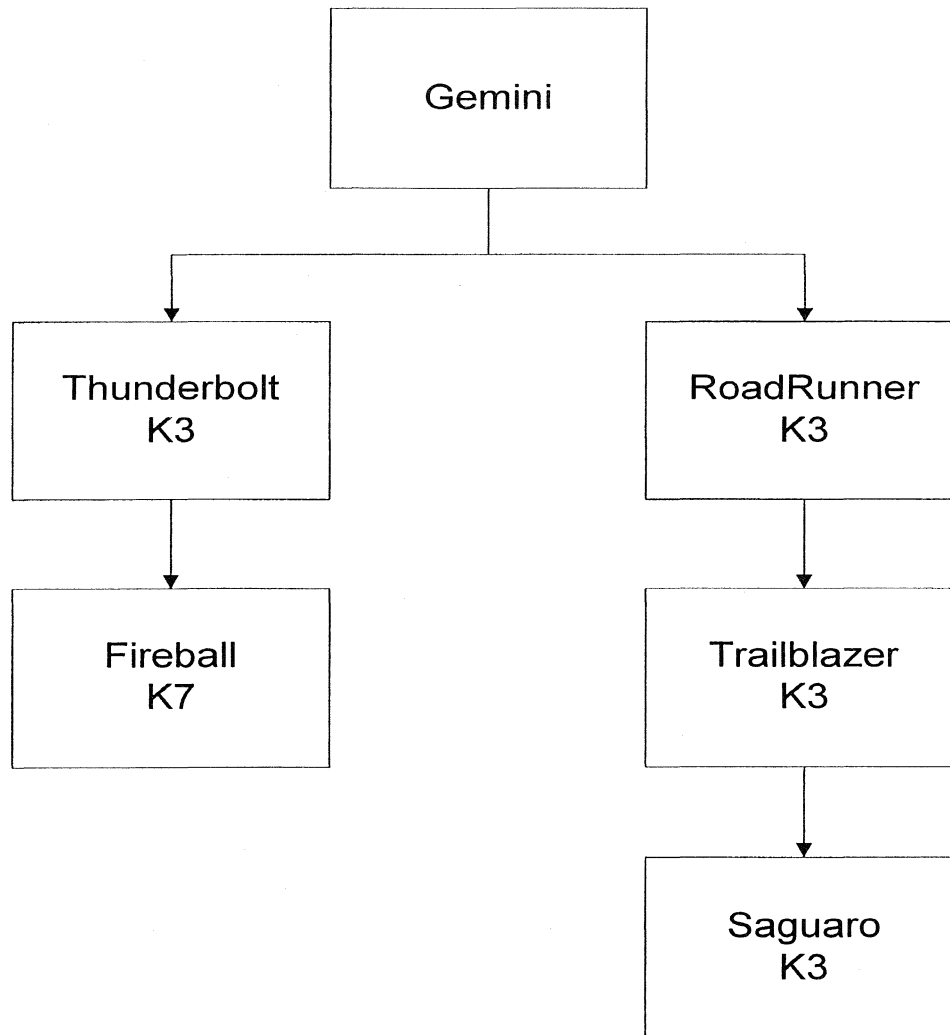

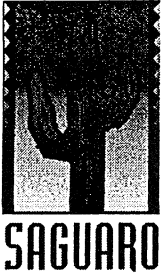

# FIRMWARE ORGANIZATION

SG 1.0/2.1

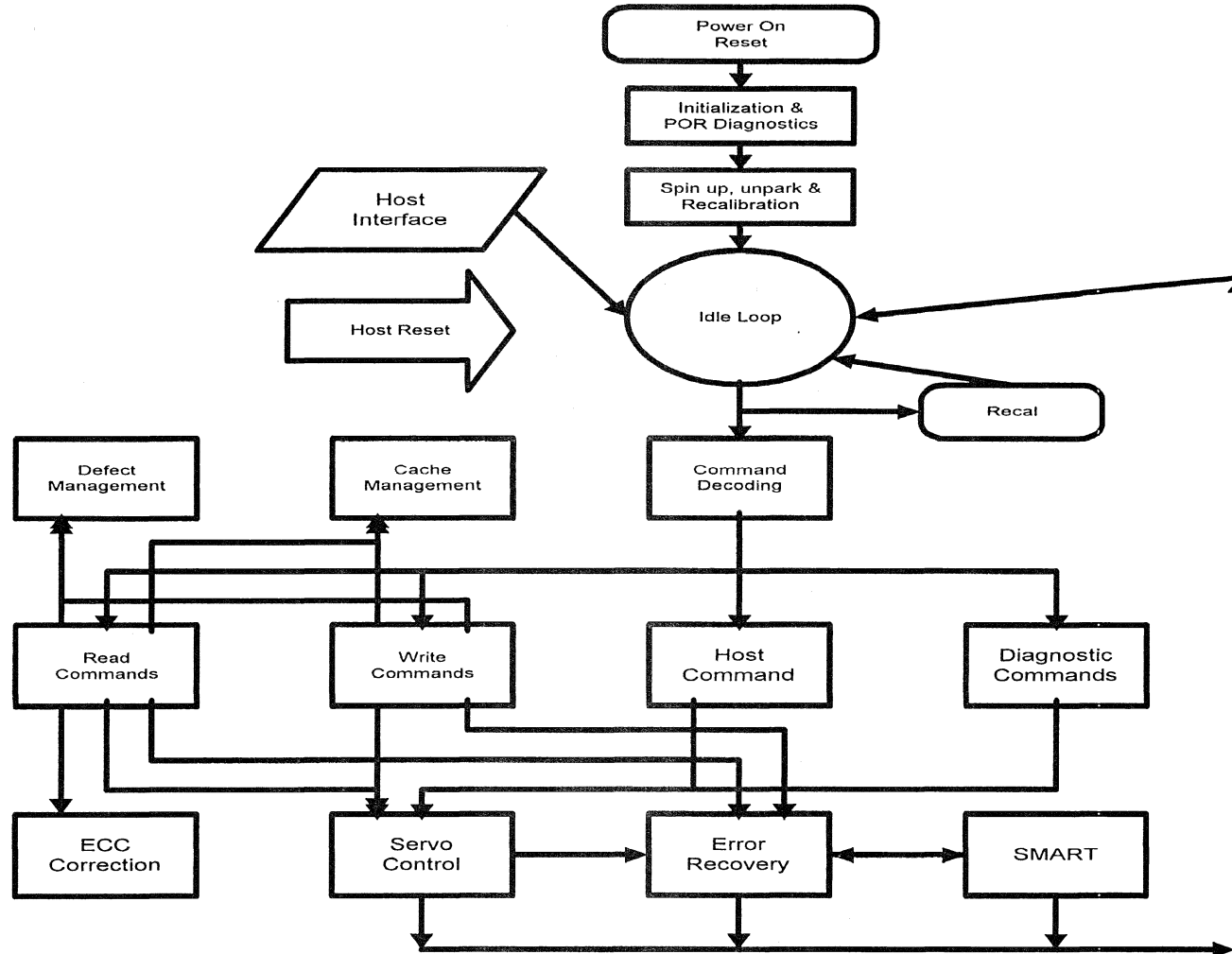



SAGUARO

# Memory Map

SRAM

CPU

*SG 1.0/2.1*

FFFF

FC00

Variables

C000

Cache

32K  
Cache  
RAM

8000

Overlay

C000

Diskware

0000

Resident

8000

CPU  
ROM

ROM

0000

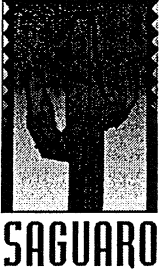

# New Firmware Features

SG 1.0/2.1

## Saguaro

- ◆ Single Burst H/W ECC Correction
- ◆ Pseudo Index to speed up Format process
- ◆ 5 data segment
- ◆ Greater than 256 sectors per track
- ◆ Overlap RG to improve format efficiency

## Trailblazer

- ◆ Firmware Correction
- ◆ Hard Index
- ◆ 4 Data Segment
- ◆ Less than 256 sectors per track

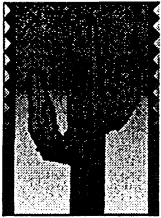

SAGUARO

# New Firmware Features, Cont

## Saguaro

## Trailblazer SG 1.0/2.1

- ◆ New defect management.
  - One Spare per track
  - Support up to 3880 defect entries
  - 5 byte per defect entry
  - Separate inline and offline defect list
  - Separate inline defect list by heads
  - Cylinder sparing
  - Apple transparent auto-reallocation
  - New Quantum standard Read Defect command
- One spare per cylinder
- Support up to 426 defect entries
- 6 byte per defect entry
- Combined defect list
- No cylinder sparing
- No transparent auto-reallocation

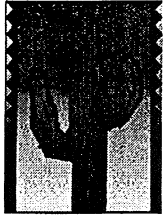

SAGUARO

# New Firmware Features, Cont

## Saguaro

## Trailblazer

SG 1.0/2.1

- ◆ 64K SRAM
- ◆ New Super command overlay
- ◆ Dynamic cache size allocation
- ◆ Power On Sweeping for contact recording
- ◆ Servo Patrol Mode for contact recording
- ◆ SMART 4.1
- ◆ Time Stamp
- ◆ H/W Servo PER calculation



SAGUARO

# New Firmware Features, Cont

*SG 1.0/2.1*

- ◆ New Super commands to support PRML channel debugging
- ◆ New Factory Format option to initialize defect list
- ◆ New configuration page 1 jumper reading
- ◆ New command to support get negative track layout
- ◆ New configuration page 20 & 24
- ◆ New CP10 & CP17 for PRML channel.
- ◆ Change Call subroutine command to use CDB4,5 for address

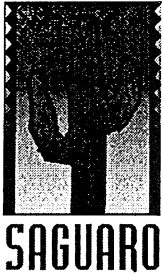

# SAGUARO CACHE

*SG 1.0/2.1*

- ◆ Variable cache buffer size from 32k to 41k depending on D/W code size
- ◆ Dynamically allocate from 1 to 4 cache segments
- ◆ Maximum read segment size = cache buffer size - rd/wr set multiple block size
- ◆ Maximum write segment size = cache buffer size
- ◆ Auto reallocate to max. segment size in sequential or nearly sequential mode



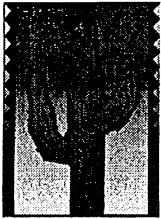

SAGUARO

# SAGUARO CACHE (Continued)

*SG 1.0/2.1*

- ◆ Minimum cache segment size =
  - Cache buffer size /4
- ◆ Support full hit, partial hit:
  - Continuously prefetch upto max segment size in sequential reads
- ◆ Concurrent read/write:
  - Read full hit occurred during Hyper Write
- ◆ Auto-read on the fly:
  - A stream of full hit reading, F/W will simply enlarge cache size and update variables for more prefetched data.

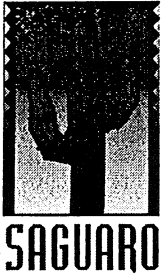

# SAGUARO CACHE (Continued)

*SG 1.0/2.1*

- ◆ Sequential Mode:
  - Sequential LBA
- ◆ Nearly Sequential mode:
  - Not Sequential LBA but the LBA is within prefetch range
- ◆ Random Mode:
  - LBA is not sequential nor within prefetch range
- ◆ Auto Read:
  - Sequential Read
- ◆ Flying Auto Read:
  - Auto Arming in Sequential Read

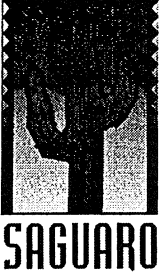

# Defect Management

*SG 1.0/2.1*

- ◆ One Spare Sector per track
  - Different lists are stored on system cylinder -2 and -3:
    - Factory Inline list -
      - The list contains the defects found in defect scans at the factory.
      - The P list contains the locations of the defects only.
      - There is a 4K list for each head.
    - Working list (Offline list) -
      - Combination of Factory and Grown Defects.
      - It is a 3K list per drive.
    - Grown Inline list -
      - this list contains the grown inline defects (normally used by SCSI only.)
    - Inline Bit Map list

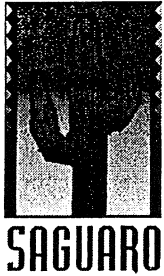

# Defect Management, Cont

*SG 1.0/2.1*

- ◆ Types of Defects:
  - Inline Sparing
  - Offline Sparing
  - Orphan
  - Pending Defect
  
- ◆ Disable Write Cache if defect list reaches to the last 6 defect entries

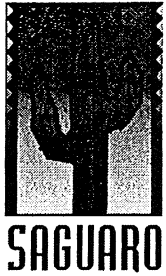

# Example of Inline & Offline Spares

SG 1.0/2.1

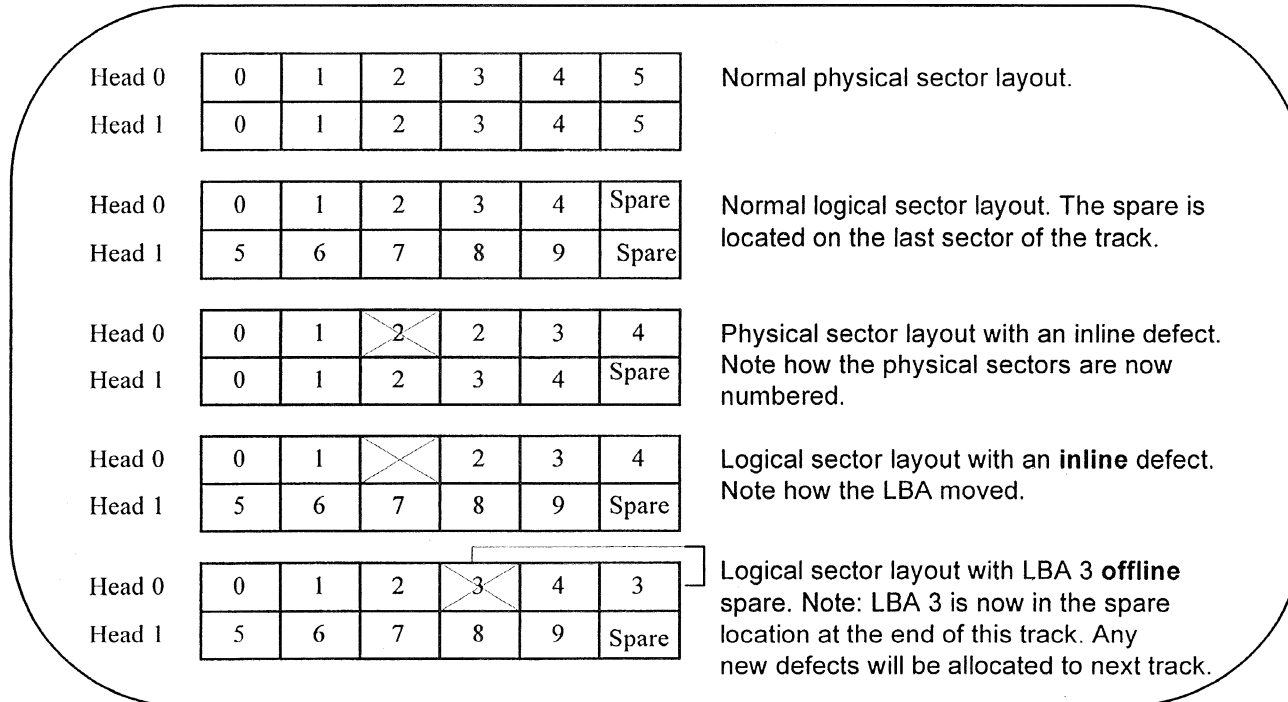

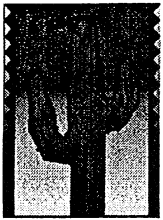

SAGUARO

# Defect List Data Structure

SG 1.0/2.1

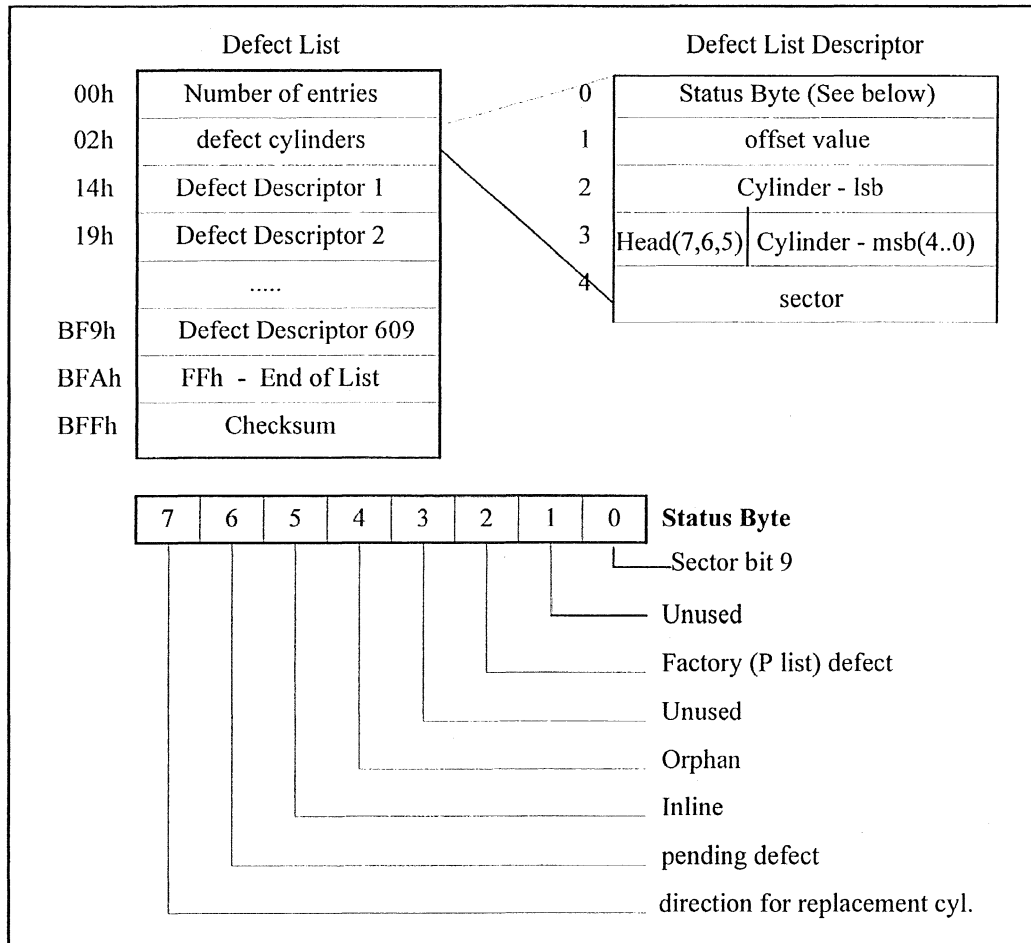



SAGUARO

# Defect List Storage Map

Sector usage of cylinder -2 and -3 are:

SG 1.0/2.1

<u>Sector</u>	<u>Description</u>	<u>Size</u>
0	Saved mode pages 1, 2, 20h, 37h, 38h, and 39h	1
1	Saved mode pages 3 and 4	1
2-7	Configuration pages	6
8-15	Offline defect list (grown defect list)	8
16-23	Grown inline defect list (SCSI)	8
24-31	P list for head 0	8
32-39	P list for head 1	8
40-47	P list for head 2	8
48-55	P list for head 3	8
56-57	Bit map list for head 0	2
58-59	Bit map list for head 1	2
60-61	Bit map list for head 2	2
62-63	Bit map list for head 3	2
64-65	Temporary buffer sectors	2
66-82	Format header bytes for 17 zones	17
83	DPA attribute sector	1
84	DPA variables sector	1
85	DPA threshold sector	1
86-194	Reserved	109

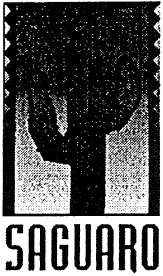

# Read Defect List

*SG 1.0/2.1*

See Saguaro Training Manual  
for these pages.



### 6.7.17 Read Defect List

The READ DEFECT LIST command enables the host to retrieve the drive's defect list. Prior to issuing the Read Defect List command the host should issue the Read Defect List Length command. This command will not transfer any data. It instead stores the length in sectors of the defect list in the Sector Count register (1F2), and the Sector Number register (1F3), with the Sector Count register containing the LSB of the 2-byte value (see Table 6-18). The defect-list length is a fixed value for each Quantum product and can be calculated as follows:

$$\text{length in sectors} = (((\text{maximum number of defects}) * 8 + 4) + 511) / 512$$

At the completion of the command, the task file registers 1F2 - 1F6 will contain bytes necessary to execute the Read Defect List command, and the host will only need to write the extended command code (F0h) to the Command register (1F7) to proceed with the Read Defect List command execution.

**Table 6-18 READ DEFECT LIST LENGTH Command Bytes**

ADDRESS	VALUE (Before)	DEFINITION	VALUE (After)
1F2	0	Defect List Subcode	Length in Sectors (LSB)
1F3	FFh	Password	Length in Sectors (MSB)
1F4	FFh	Password	FFh
1F5	3Fh	Password	3Fh
1F6	AXh (Drive 0)	Drive Select	AXh = Drive 0
	BXh (Drive 1)	—	BXh = Drive 1
1F7	F0h	Extended Command Code	Status Register

Note: Registers 1F2h through 1F5h must contain the exact values shown. These values function as a key. The drive issues the message **ILLEGAL COMMAND** if the bytes are not entered correctly.

The AT Read Defect List command is an extended AT command that enables the host to retrieve the drive's defect list. The host begins by writing to address 1F6h to select the drive. Then the host writes to addresses 1F2h - 1F5h using values indicated in Table 6-19. When the host subsequently writes the extended command code F0h to address 1F7h, the drive sets BSY, retrieves the defect list, sets DRQ, and resets BSY. The host can now read the requested number of sectors (512 bytes) of data. An INTRQ precedes each sector. Bytes 1F2h and 1F3h contain the 2-byte number of sectors that the host expects to read, with address 1F2h containing the LSB (see Table 6-19). The sector count (1F2h - 1F3h) may vary from product to product and if the wrong value is supplied for a specific product, the drive will issue the **ILLEGAL COMMAND** message. If the host does not know the appropriate sector count for a specific product, it can issue the Read Defect List Length command, described in the previous section to set up the task file for the Read Defect List command.

**Table 6-19 AT READ DEFECT LIST Command Bytes**

ADDRESS	VALUE	DEFINITION
1F2	Length in Sectors (LSB)	Defect List Subcode
1F3	Length in Sectors (MSB)	Defect List Subcode
1F4	FFh	Password
1F5	3Fh	Password
1F6	AXh = Drive 0	Drive Select
	BXh = Drive 1	—
1F7	F0h	Extended Command Code

Note: Registers 1F2h and 1F3h must contain the transfer length that is appropriate for the specific product, and 1F4h and 1F5h must contain the exact values shown. These values function as a key. The drive issues the message **ILLEGAL COMMAND** if the bytes are not entered correctly.

Pending defects will be excluded from the list, since no alternate sector is being used as their replacement, and since they may be removed from the drive's internal pending list at a later time. Table 6-20 shows the overall format of the defect list, and Table 6-21 shows the format of the individual defect entries.

**Table 6-20 DEFECT LIST DATA FORMAT**

BYTE	DESCRIPTION
0	0
1	1Dh
2	8* (Number of Defects) (MSB)
3	8* (Number of Defects) (LSB)
4-11	Defect Entry #1
12-19	Defect Entry #2
	•
	•

**Table 6-21 DEFECT ENTRY DATA FORMAT**

BYTE	DESCRIPTION
0	Defect cylinder (MSB)
1	Defect cylinder
2	Defect cylinder (LSB)
3	Defect head
4	Defect sector (MSB)
5	Defect sector
6	Defect sector
7	Defect sector (LSB)

Note: Bytes 4 - 7 will be set to FFh for bad track entries.

### 6.7.18 Configuration

In addition to the SET FEATURES command, the Quantum Pioneer SG 1.0/2.1AT hard disk drives provide two configuration commands:

- The SET CONFIGURATION command which enables the host to change DisCache and Error Recovery parameters
- The READ CONFIGURATION command which enables the host to read the current configuration status of the drive

See Chapter 5 for more details about DisCache and setting cache parameters. See Chapter 5 also for more information about error detection and defect management.

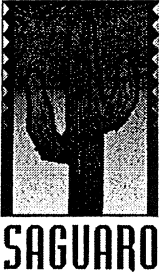

# Error Recovery Algorithm

*SG 1.0/2.1*

- ◆ Single Burst Hardware ECC Correction on the Fly
- ◆ Double Burst Firmware ECC Correction on the Fly
- ◆ Wiggle retry on every retry pass
- ◆ 6% Off Track Read recovery on both ID and OD
- ◆ Triple Burst Offline ECC Correction

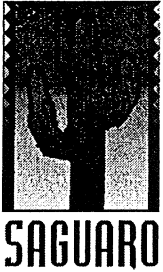

# Error Recovery Algorithm, Cont

*SG 1.0/2.1*

- ◆ Auto reallocation on Hyper Write Error until defect list is full (6 entries left)
- ◆ Read Retries : OnTrack, OnTrack, ID OffTrack, OnTrack, OD OffTrack, OnTrack, ECC Offline
- ◆ Write Retries : 6 OnTrack retries
- ◆ Pending Error on uncorrectable data error.
- ◆ Auto-reallocation of pending error on the Write Command
- ◆ Auto-reallocation on correctable read error and write error

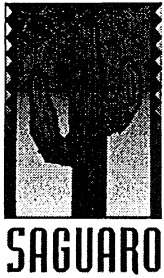

# Read Error Flow Chart

SG 1.0/2.1

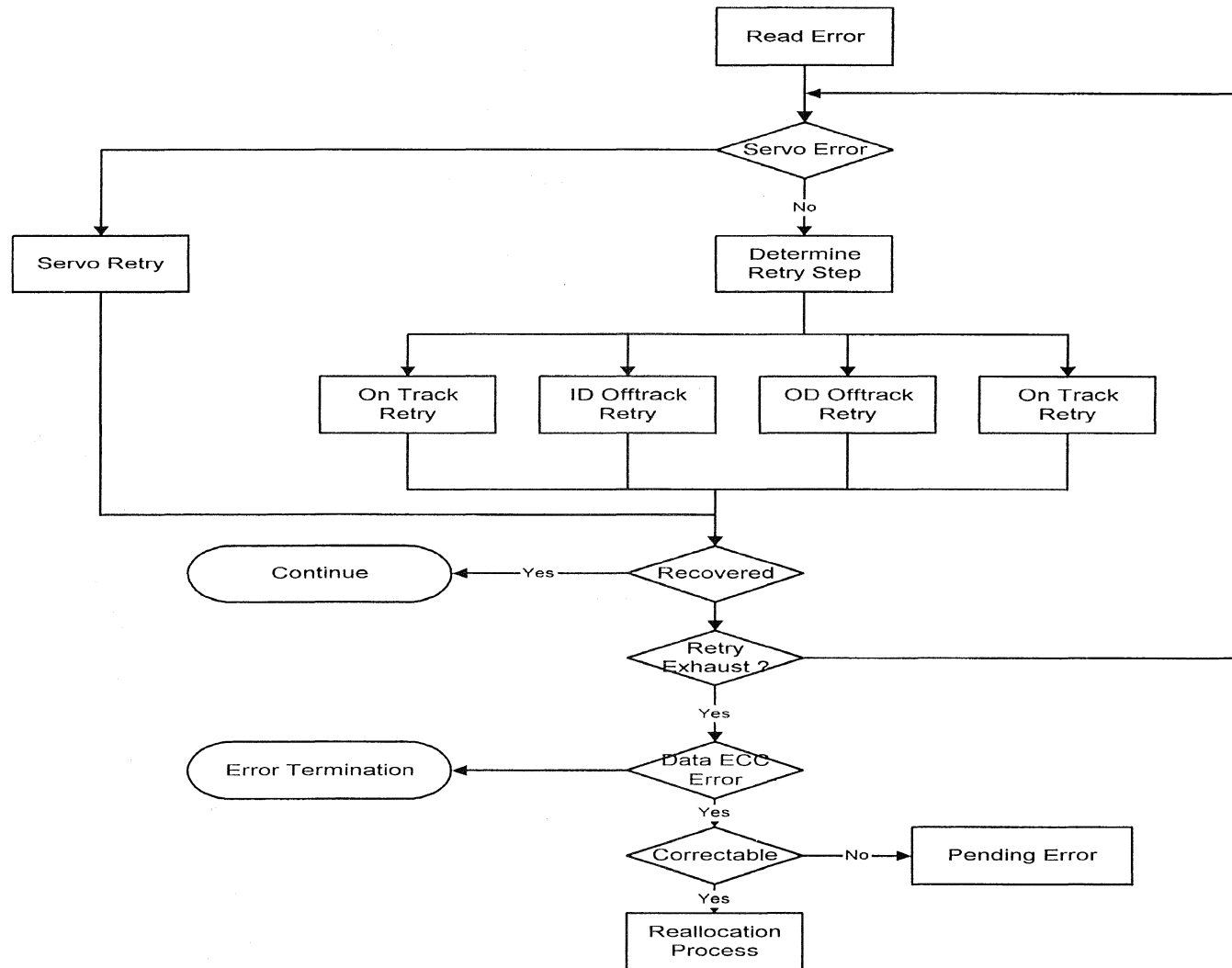



SAGUARO

# Write Error Flow Chart

SG 1.0/2.1

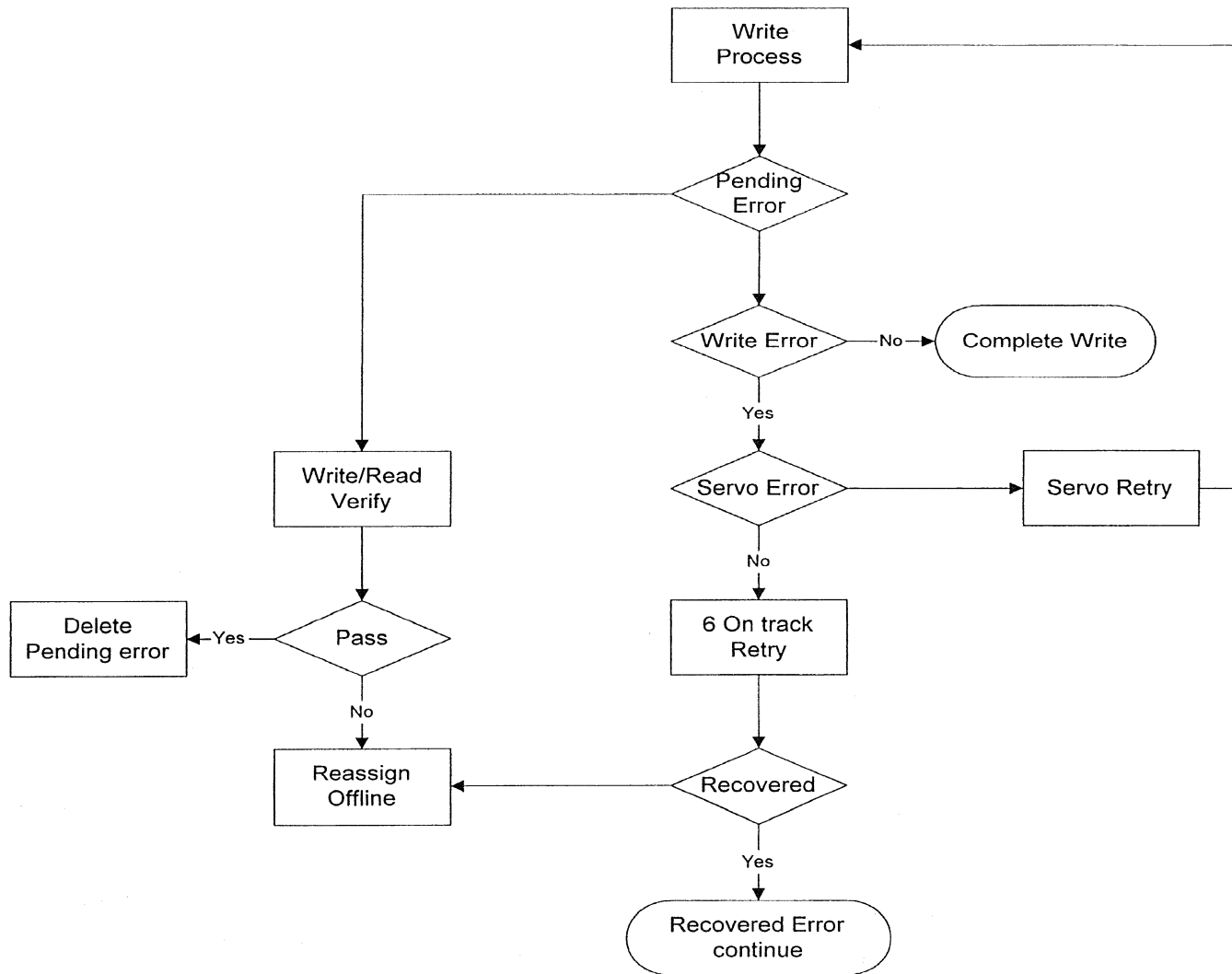

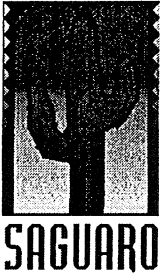

# Power Mode

*SG 1.0/2.1*

- ◆ Full Power Mode
  - Spining, Active Command, Seek, Read/ Write
- ◆ Idle Servo Mode
  - Spining, No Active Command
- ◆ Standby Mode
  - Spin Down Mode, any new command wakes up the drive
- ◆ Sleep Mode
  - Spin Down Mode, only Reset can wake up the drive





# Servo Patrol

*SG 1.0/2.1*

- ◆ Power On Sweeping :
  - From OD to ID
  - Sweep every track in the background
  - Disable able cache
  - Verify for write command
- ◆ Servo Patrol : Auto seek when drive is not active
  - Programmable Timers
    - T1 : Time to first seek (eg. 15 min)
    - T2 : Seek interval (eg. 30 sec)
  - Programmable seek step size (eg. 30 tracks)



**SAGUARO**

# Configuration Pages

---

*SG 1.0/2.1*

See Saguaro Training Manual  
for these pages.

## Saguaro Configuration Pages

Rev 02 : New Patrol & Sweep control

10/18/96

Page	Length	Content	Default
0	1	Customer page.	0
		0 = Generic	
		1 = Apple	
1	2	Jumper setting page. (Read from ASIC jumper register.)	-
		* Read Only	
2	16	ASCII "QUANTUM"	"QUANTUM"
		* Need to fill the remaining field with space (20H).	
3	16	Product ID.	"PIONEER-1080A ""*
		2 head drive = "PIONEER-1080A "	
		3 head drive = "PIONEER-1620A "	
		4 head drive = "PIONEER-2160A "	
		* Need to fill the remaining field with space (20H).	
4	8	Drive revision.	
		* Need to fill the remaining field with space (20H).	
5	12	Drive serial number.	
		* Need to fill the remaining field with space (20H).	
6	32	Customer name in ASCII.	"GENERIC"
		"GENERIC"	
		* Need to fill the remaining field with space (20H).	
7	10	AT configuration page.	
		byte 0 : AT configuration flag 1	60H
		bit 0 : Disable LED to reduce DASP noise coupling.	
		bit 1 : Disable Verify Prefetch	
		bit 2 : Disable wiggle retry.	
		bit 3 : Enable cache debug.	
		bit 4 : Enable command history.	
		bit 5 : Enable Leo AT auto arming.	
		bit 6 : Enable Leo AT auto read.	
		bit 7 : Enable ACCU-WRITE. Default is no accu-write.	
		byte 1 : AT configuration flag 2	80H
		bit 0 :-	
		bit 1 : Enable seek off track.	
		bit 2 :-	
		bit 3 :-	
		bit 4 - 5 : I/O Read delay.	
		0, 0 = 0 ns	
		0, 1 = 10 ns	
		1, 0 = 20 ns	
		1, 1 = 30 ns	
		bit 6 - 7 : DMA mode	
		0, 0 = mode 1	
		0, 1 = mode 2	
		1, 0 = mode 3	
		1, 1 = (Invalid)	

		byte 2 - 3 : AT logical cylinders per drive.	2101*
		SG1080 = 2101	
		SG1620 = 3152	
		SG2160 = 4203	
		byte 4 : AT logical heads per drive.	16*
		SG1080 = 16	
		SG1620 = 16	
		SG2160 = 16	
		byte 5 : AT logical sectors per track.	63*
		SG1080 = 63	
		SG1620 = 63	
		SG2160 = 63	
		byte 6 : Min. power down timeout for AT power commands.	1
		byte 7 : AT read IRQ delay.	00H
		byte 8 : AT write IRQ delay.	00H
		byte 9 : Reserved	0
8	1	Number of heads.	2*
		SG1080 = 2	
		SG1620 = 3	
		SG2160 = 4	
9	16	Configuration validation page	
		0, 1, 0FF, 2, 0FE, 3, 0FD, 4, 0FC, 5, 0FB, 6, 0FA, 7, 0F9, 8	
10	297	Non adaptive Zone tables.	
		byte 0 - 1 : zone 0 starting cylinder.	
		byte 2 - 4 : zone 0 starting LBA.	
		<b>byte 5 - 6 : zone 0 sectors per track.</b>	
		byte 7 - 8 : zone 0 sectors per Cylinder. (SCSI zone)	
		byte 9 : zone 0 synthesizer frequency. (Fb.) (reg. 0BH)	
		byte 10 : zone 0 synthesizer frequency. (Pres.) (reg. 0AH)	
		byte 11 : zone 0 synthesizer. (reg. 13H)	
		byte 12 : zone 0 Servo Bandwidth. (reg. 04H)	
		byte 13 : zone 0 Servo Boost. (reg. 02H)	
		byte 14 : zone 0 Servo Threshold. (reg. 0DH)	
		byte 15 : 2SP byte count.	
		byte 16 : Not Used	
		Repeat byte 0 to 16 for Zone 1 to Zone 16.	
		byte 289 - 290 : Total number of cylinders.	5331
		byte 291 - 293 : Total number of sectors.	
		SG1080 = 2,118,564	
		SG1620 = 3,177,846	
		SG2160 = 4,237,128	
		byte 294 : Head skew. (Number of wedge skew)	33
		byte 295 : Cylinder skew. (Number of wedge skew)	33
		byte 296 : Revision number.	25

11	3	Number of user accessible sectors. (LSB first)	OFF, OFF, OFF
12	1	Scope trigger mask.	0FF
		bit 0 : bump error	
		bit 1 : seek timeout	
		bit 2 : seek fault	
		bit 3 : other servo fault	
		bit 4 : ECC error	
		bit 5 : sequencer error	
		bit 6 : sequencer overrun/underrun	
		bit 7 : sequencer timeout	
13	2	Drive family code and model ID number.	
		Family code is 1CH.	1CH
		Model ID is as following.	
		SG1080 = 1	1*
		SG1620 = 2	
		SG2160 = 3	
14	6	Head mapping page.	
		byte 0 - 2 : Hardware head mapping information.	03,00,00 (1080MB)
		Bit number n is set if head n was found in Recal.	0F,00,00 (2160MB)
		byte 3 - 5 : User head mapping information.	03,00,00 (1080MB)
		Bit number n is set if head n is mapped into use.	0F,00,00 (2160MB)
15	91	Diskware overlay page.	
		byte 0 : Overlay number.	
		byte 1 - 2 : Loading address.	
		byte 3 : Number of sectors.	
		byte 4 - 5 : Cylinder number.	
		byte 6 - 7 : Alternate cylinder number.	
		byte 8 : Starting sector number.	
		Repeat byte 0 - 8 for overlay number 1 to 9	
		byte 90 : end of table. 0FFH	0FFH
16	1	HDA flag page.	
		byte 0 : HDA flag byte 0	0C0H
		bit 0 : No spin down on power up recal fail.	
		bit 1 : Allow drive to attempt recal on fatal error.	
		bit 2 : No Find Mode. Bit set will disable servo find mode.	
		bit 3 : Disable idle servo.	
		bit 4 : Skip Record Taking	
		bit 5 : Enable servo record taking mode.	
		bit 6 : Enable read on arrival.	
		<b>bit 7 : Enable Servo Patrol.</b>	
17	953	Channel Zone tables. (Adaptive parameters.)	
		byte 0 : zone 0 head 0 FIR4 (reg. 17H).	

		byte 1 : zone 0 head 0 FIR1 (reg. 18H).	
		byte 2 : zone 0 head 0 FIR3 (reg. 19H).	
		byte 3 : zone 0 head 0 Offset (reg. 29H).	
		byte 4 : zone 0 head 0 Read BW (reg. 03 and 13H).	
		byte 5 : zone 0 head 0 ReadBoost (reg. 01H).	
		byte 6 : zone 0 head 0 VGAtst (reg. 2bH).	
		byte 7 : zone 0 head 0 ZPR (reg. 10H).	
		byte 8 : zone 0 head 0 PreComp (reg. 09H).	
		byte 9 : zone 0 head 0 trailing coefficient (reg 25h)	
		byte 10 : zone 0 head 0 leading coefficient. (reg 26h)	
		byte 11 : zone 0 head 0 trailing delay. (reg 27h)	
		byte 12 : zone 0 head 0 leading delay. (reg 28h)	
		byte 13 : zone 0 head 0 WriteCurrent (PWM)	
		byte 14 - 27 : Repeat byte 0 - 13 for head 1.	
		byte 28 - 41 : Repeat byte 0 - 13 for head 2.	
		byte 42 - 55 : Repeat byte 0 - 13 for head 3.	
		byte 56 - 111 : Repeat byte 0 - 55 for zone 1.	
		byte 112 - 167 : Repeat byte 0 - 55 for zone 2.	
		.	
		.	
		byte 896 - 951 : Repeat byte 0 - 55 for zone 16.	
		byte 952 Drive Fcomp value	
18	360	Servo parameter page.	
	<b>4C,</b> <b>4D</b>	Time to start Servo Patrol in Second	?
	<b>61</b> <b>H</b>	Servo Patrol Track Length	30
	<b>90-</b> <b>91</b> <b>H</b>	Servo Patrol Timer in unit of second	12CH
	?	Sweeping control ?	?
19	18	Error log page. (DPA page)	
		byte 0 - 1 : Disk logging interval in second.	0, 0
		(byte 1, bit 7 = 1 : enable DPA)	
		byte 2 - 5 : Max. # of seeks for one data range.	OFF, OFF
		byte 6 : Max. # of seek errors for one data range.	OFF
		byte 7 - 10 : Max. # of sectors read for one data range.	OFF, OFF
		byte 11 : Max. # of read errors for one data range.	OFF
		byte 12 - 13 : Max. # of spinup for one data range.	OFF, OFF
		byte 14 - 15 : Max. spinup time.	OFF, OFF
		byte 16 : Max. # of recal retry for one data range.	OFF
		byte 17 : spare	OFF
		byte 18 - 19 : Total offline blocks to read.	OFF, OFF
		byte 20 : logical blocks/seek	OFF
		byte 21 : Max. # of offline read errors	OFF
		byte 22 : Revision.	00
20	5	Aiko specific page.	0

	byte 0,1	DWARE (0FB18H) Diskware sequential prefetch address boundary registers.	01, 08BH
	byte 2	Buffer config 1 register. CONFIG1 (0FB1EH)	07CH
	byte 3	Buffer config 2 register. CONFIG 2 (0FB1FH)	04
	byte 4	H/W ECC control register. ECTRL (0FB9AH)	00
21	1	Reserved. (Adaptable servo parameters)	0
22	3	SCSI EEPROM page.	
		byte 0 : QCP bits.	0
		byte 1 : SCSI glitch filter.	0
		byte 2 : SCSI data slew rate control.	10H
		bit 0 - 1: Req slew rate control	
		0, 0 : slow	
		0, 1 : medium	
		1, x : fast	
		bit 2 - 3 : Data slew rate control.	
		0, 0 : slow	
		0, 1 : medium	
		1, x : fast	
		bit 4 : Req pull up enable.	
		bit 5 : Data pull up enable.	
23	1	Reserved. (MR microjog).	0
24	30	ATA Identify command programmable parameters.	
	0	Word 47	02F
	1,2	Max number of sector for set multiple command.	08,0
	3	ID data word offset pointer ??	0FF
	4,5	Value of this ID word.	0,0
	6	ID data word offset pointer ??	0FF
	7,8	Value of this ID word.	0,0
	9	ID data word offset pointer ??	0FF
	10, 11	Value of this ID word.	0,0
	12	ID data word offset pointer ??	0FF
	13, 14	Value of this ID word.	0,0
	15	ID data word offset pointer ??	0FF
	16, 17	Value of this ID word.	0,0
	18	ID data word offset pointer ??	0FF
	19, 20	Value of this ID word.	0,0
	21	ID data word offset pointer ??	0FF
	22, 23	Value of this ID word.	0,0
	24	ID data word offset pointer ??	0FF

25, 26	Value of this ID word.	0,0
27	ID data word offset pointer ??	0FF
28, 29	Value of this ID word.	0,0



## Saguaro AT Read/Write Configuration Data

	bit								default
byte	7	6	5	4	3	2	1	0	
0 - 31	Quantum configuration key								
32							PE	CE	03
33	Number of cache segments								08
34	Reserved = 0								0
35	Reserved = 0								0
36	AWRE	ARR	-	RC	EEC	-	-	DCR	0C0H
37	Number of retries								08
38	ECC Correction Span								24
39	VP	AR	Aarm	-	-	WCE	RUEE	-	66H
40-511	Reserved = 0								0

# Saguaro SMART (DPA) Parameters

## Attribute Data Structure

Description	bytes	format	type
Attribute ID Number	1	binary	rd only
Status flags	2	bit flags	rd only
Pre-Failure Warranty bit			
On-line Collection bit			
Performance Attribute type bit			
Error Rate Attribute type bit			
Event Count Attribute type bit			
Self-Preserving Attribute type bit			
Reserved bits (0x00)			
Normalized Attribute Value	1	binary	rd only
(valid values from 0x01 to 0xFE)			
0x00 invalid for Attribute value - not to be used			
0x01 minimum value			
0x64 initial value for all attributes prior to any data collection			
0xFD maximum value			
0xFE value is not valid			
0xFF invalid for Attribute value - not to be used			
Worst Ever Normalized Attribute Value	1	binary	rd only
(valid values from 0x01 to 0xFE)			
Raw Attribute Value	6	binary	rd only
(drive specific, values determined by the supplier)			
(0xFFFFFFFFFFFF = reserved for counts that are saturated)			
Reserved (0x00)	1	binary	rd only

## Attribute ID 0

Description	bytes	format	Value
Attribute ID Number (0 indicates this entry is not used)	1	binary	0
Status flags	2	bit flags	
Normalized Attribute Value	1	binary	
Worst Ever Normalized Attribute Value	1	binary	
Raw Attribute Value	6	binary	
Reserved (0x00)	1	binary	

## Attribute ID 1 : Raw Read Error Rate

## Saguaro Configuration Information

Description	bytes	format	Value
Attribute ID Number (0 indicates this entry is not used)	1	binary	1
Status flags	2	bit flags	09
Normalized Attribute Value	1	binary	
Worst Ever Normalized Attribute Value	1	binary	
Raw Attribute Value	6	binary	
Reserved (0x00)	1	binary	

Attribute ID 2 : Throughput Performance

Description	bytes	format	Value
Attribute ID Number (0 indicates this entry is not used)	1	binary	2
Status flags	2	bit flags	
Normalized Attribute Value	1	binary	
Worst Ever Normalized Attribute Value	1	binary	
Raw Attribute Value	6	binary	
Reserved (0x00)	1	binary	

Attribute ID 3 : Spin Up Time

Description	bytes	format	Value
Attribute ID Number (0 indicates this entry is not used)	1	binary	3
Status flags	2	bit flags	27H
Normalized Attribute Value	1	binary	
Worst Ever Normalized Attribute Value	1	binary	
Raw Attribute Value	6	binary	
Reserved (0x00)	1	binary	

Attribute ID 4 : Start/Stop Count

Description	bytes	format	Value
Attribute ID Number (0 indicates this entry is not used)	1	binary	4
Status flags	2	bit flags	32H
Normalized Attribute Value	1	binary	
Worst Ever Normalized Attribute Value	1	binary	
Raw Attribute Value	6	binary	
Reserved (0x00)	1	binary	

Attribute ID 5 : Reallocated Sector Count

Description	bytes	format	Value
Attribute ID Number (0 indicates this entry is not used)	1	binary	5
Status flags	2	bit flags	32H
Normalized Attribute Value	1	binary	
Worst Ever Normalized Attribute Value	1	binary	

Raw Attribute Value	6	binary	
Reserved (0x00)	1	binary	

Attribute ID 6 : Read Channel Margin

Description	bytes	format	Value
Attribute ID Number (0 indicates this entry is not used)	1	binary	6
Status flags	2	bit flags	
Normalized Attribute Value	1	binary	
Worst Ever Normalized Attribute Value	1	binary	
Raw Attribute Value	6	binary	
Reserved (0x00)	1	binary	

Attribute ID 7 : Seek Error Rate

Description	bytes	format	Value
Attribute ID Number (0 indicates this entry is not used)	1	binary	7
Status flags	2	bit flags	0BH
Normalized Attribute Value	1	binary	
Worst Ever Normalized Attribute Value	1	binary	
Raw Attribute Value	6	binary	
Reserved (0x00)	1	binary	

Attribute ID 8 : Seek Time Performance

Description	bytes	format	Value
Attribute ID Number (0 indicates this entry is not used)	1	binary	8
Status flags	2	bit flags	
Normalized Attribute Value	1	binary	
Worst Ever Normalized Attribute Value	1	binary	
Raw Attribute Value	6	binary	
Reserved (0x00)	1	binary	

Attribute ID 9 : Power-On Hours Count

Description	bytes	format	Value
Attribute ID Number (0 indicates this entry is not used)	1	binary	9
Status flags	2	bit flags	12H
Normalized Attribute Value	1	binary	
Worst Ever Normalized Attribute Value	1	binary	
Raw Attribute Value	6	binary	
Reserved (0x00)	1	binary	

Attribute ID 10 : Spin-up Retry Count

Description	bytes	format	Value

Saguaro Configuration Information

Attribute ID Number (0 indicates this entry is not used)	1	binary	10
Status flags	2	bit flags	
Normalized Attribute Value	1	binary	
Worst Ever Normalized Attribute Value	1	binary	
Raw Attribute Value	6	binary	
Reserved (0x00)	1	binary	

Attribute ID 11 : Drive Calibration Retry Count

Description	bytes	format	Value
Attribute ID Number (0 indicates this entry is not used)	1	binary	11
Status flags	2	bit flags	13H
Normalized Attribute Value	1	binary	
Worst Ever Normalized Attribute Value	1	binary	
Raw Attribute Value	6	binary	
Reserved (0x00)	1	binary	

Attribute ID 12 : Drive Power Cycle Count

Description	bytes	format	Value
Attribute ID Number (0 indicates this entry is not used)	1	binary	12
Status flags	2	bit flags	32
Normalized Attribute Value	1	binary	
Worst Ever Normalized Attribute Value	1	binary	
Raw Attribute Value	6	binary	
Reserved (0x00)	1	binary	

Attribute ID 13 : Read Soft Error Rate

Description	bytes	format	Value
Attribute ID Number (0 indicates this entry is not used)	1	binary	13
Status flags	2	bit flags	0BH
Normalized Attribute Value	1	binary	
Worst Ever Normalized Attribute Value	1	binary	
Raw Attribute Value	6	binary	
Reserved (0x00)	1	binary	

## Drive Attribute Threshold Data Structure

Description	bytes	format	type
Attribute ID Number (0 indicates this entry is not used)	1	binary	rd only
Warranty Failure Threshold	1	binary	rd/write
(For comparison with normalized attribute values from 0x00 to 0xFF)			
0x00 "always passing" threshold value to be used for code test purposes			
0x01 minimum value for normal operation			
0xFD maximum value for normal operation			
0xFE invalid for threshold value - not to be used			
0xFF "always failing" threshold value to be used for code test purposes			
Reserved (0x00)	10	binary	rd/write

### Drive Attribute Threshold ID 1 : Raw Read Error Rate

Description	bytes	format	value
Attribute ID Number	1	binary	1
Warranty Failure Threshold	1	binary	
Reserved (0x00)	10	binary	00

### Drive Attribute Threshold ID 2 : Throughput Performance

Description	bytes	format	value
Attribute ID Number	1	binary	2
Warranty Failure Threshold	1	binary	
Reserved (0x00)	10	binary	00

### Drive Attribute Threshold ID 3 : Spin-up Time

Description	bytes	format	value
Attribute ID Number	1	binary	3
Warranty Failure Threshold	1	binary	
Reserved (0x00)	10	binary	00

### Drive Attribute Threshold ID 4 : Start/Stop Count

Description	bytes	format	value
Attribute ID Number	1	binary	4
Warranty Failure Threshold	1	binary	
Reserved (0x00)	10	binary	00

Drive Attribute Threshold ID 5 : Re-allocated Sector Count

Description	bytes	format	value
Attribute ID Number	1	binary	5
Warranty Failure Threshold	1	binary	
Reserved (0x00)	10	binary	00

Drive Attribute Threshold ID 6 : Read Channel Margin

Description	bytes	format	value
Attribute ID Number	1	binary	6
Warranty Failure Threshold	1	binary	
Reserved (0x00)	10	binary	00

Drive Attribute Threshold ID 7 : Seek Error Rate

Description	bytes	format	value
Attribute ID Number	1	binary	7
Warranty Failure Threshold	1	binary	
Reserved (0x00)	10	binary	00

Drive Attribute Threshold ID 8 : Seek Time Performance

Description	bytes	format	value
Attribute ID Number	1	binary	8
Warranty Failure Threshold	1	binary	
Reserved (0x00)	10	binary	00

Drive Attribute Threshold ID 9 : Power-on Hours Count

Description	bytes	format	value
Attribute ID Number	1	binary	9
Warranty Failure Threshold	1	binary	
Reserved (0x00)	10	binary	00

Drive Attribute Threshold ID 10 : Spin Retry Count

Description	bytes	format	value
Attribute ID Number	1	binary	10
Warranty Failure Threshold	1	binary	

Reserved (0x00)	10	binary	00
-----------------	----	--------	----

Drive Attribute Threshold ID 11 : Drive Calibration Retry Count

Description	bytes	format	value
Attribute ID Number	1	binary	11
Warranty Failure Threshold	1	binary	
Reserved (0x00)	10	binary	00

Drive Attribute Threshold ID 12 : Drive Power Cycle Count

Description	bytes	format	value
Attribute ID Number	1	binary	12
Warranty Failure Threshold	1	binary	
Reserved (0x00)	10	binary	00

Drive Attribute Threshold ID 13 : Read Soft Error Rate

Description	bytes	format	value
Attribute ID Number	1	binary	13
Warranty Failure Threshold	1	binary	
Reserved (0x00)	10	binary	00





# Saguaro Error Code Summary

*SG 1.0/2.1*

- ◆ error 0, No Error detected at Drive level
- ◆ error 1, EC\_BUFFER\_RAM Error probably found in diagnostic
- ◆ error 2, EC\_SEQ\_RAM\_FAIL Fail write sequencer format table
- ◆ error 3, EC\_SEQ\_ROLLOVER Sequencer rollover register failed
- ◆ error 4, EC\_ROM\_CHKSUM Internal ROM checksum error
- ◆ error 5, EC\_DW\_CHKSUM Internal ROM checksum error
- ◆ error 6, EC\_READ\_DISKWARE Error during reading of diskware
- ◆ error 7, EC\_WRONG\_VERSION Markers incompatible
- ◆ error 8, EC\_INV\_COMMAND Invalid command
- ◆ error 9, EC\_INV\_LBA Invalid LBA
- ◆ error A, EC\_INV\_CDB Invalid bits set in CDB
- ◆ error B, EC\_INV\_PARAMETER Invalid field in parameters

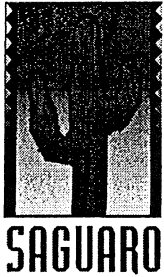

# Saguaro Error Code Summary, Cont

*SG 1.0/2.1*

- ◆ error C, EC\_INVALID\_CYL Invalid cylinder specified
- ◆ error D, EC\_INVALID\_HEAD Invalid head specified
- ◆ error E, EC\_INVALID\_SECTOR Invalid sector specified
- ◆ error F, EC\_REC\_BAD\_FORMAT Read Defect Data format not avail
- ◆ error 10, EC\_BAD\_MODE\_PAGE Bad parms in mode page while init
- ◆ error 11, EC\_RESET\_OCCURRED Reset occurred
- ◆ error 12, EC\_BAD\_DFCT\_LIST Bad defect list
- ◆ error 13, EC\_NO\_ALT\_SECTS No more alternate sectors availbl
- ◆ error 14, EC\_DFCT\_LIST\_FULL Defect list is full
- ◆ error 15, EC\_ASSERT\_ERROR Firmware consistency check err
- ◆ error 16, EC\_WRITE\_SYSTEM Error in writing system sector
- ◆ error 17, EC\_READ\_SYSTEM Error in reading system sector
- ◆ error 18, Autowr cmd received while host channel disabled



SAGUARO

# Saguaro Error Code Summary , Cont

*SG 1.0/2.1*

- ◆ error 19, EC\_BAD\_FMT\_HDR
- ◆ error 1A, SYS\_NOT\_USED\_1
- ◆ error 1B, SYS\_NOT\_USED\_2
- ◆ error 1C, SYS\_NOT\_USED\_3
- ◆ error 1D, SYS\_NOT\_USED\_4
- ◆ error 1E, EC\_DATA\_SYNC\_TMO Data field sync timeout
- ◆ error 1F, EC\_DATA\_SYNC\_TMO RECOVERED data field sync timeout
- ◆ error 20, EC\_ID\_ECC ID ECC error
- ◆ error 21, EC\_ID\_ECC RECOVERED ID ECC error
- ◆ error 22, EC\_ID\_SYNC\_TMO AM not found for ID field
- ◆ error 23, EC\_ID\_SYNC\_TMO RECOVERED ID AM mark not found
- ◆ error 24, EC\_NO\_RECORD\_FOUND No record found



SAGUARO

# Saguaro Error Code Summary, Cont

*SG 1.0/2.1*

- ◆ error 24, EC\_NO\_RECORD\_FOUND No record found
- ◆ error 25, EC\_NO\_RECORD\_FOUND RECOVERED no record found
- ◆ error 26, EC\_CRC\_CONT Marker for CRC/Continue
- ◆ error 27, EC\_CRC\_CONT RECOVERED marker CRC/Continue
- ◆ error 28, EC\_ID\_MISCOMP Read, write ID miscompare
- ◆ error 29, EC\_ID\_MISCOMP RECOVERED R/W ID miscompare
- ◆ error 2A, EC\_ID\_AM\_CONT AM not found ID intern continue
- ◆ error 2B, EC\_ID\_AM\_CONT RECOVERED ID AM not found continu
- ◆ error 2C, EC\_INVALID\_DATA Realloc of uncorrectbl data
- ◆ error 2D, EC\_INVALID\_DATA RECOVERED realloc uncorrctbl data
- ◆ error 2E, EC\_UNDERRUN Underrun error
- ◆ error 2F, EC\_UNDERRUN RECOVERED underrun error
- ◆ error 30, EC\_WG\_IN\_WEDGE Write gate asserted wedge detec



SAGUARO

# Saguaro Error Code Summary, Cont

*SG 1.0/2.1*

- ◆ error 31, EC\_NO\_INDEX\_FOUND No disk index found on track
- ◆ error 32, EC\_WRITE\_FAULT Write fault
- ◆ error 33, EC\_WRITE\_FAULT RECOVERED Write Fault
- ◆ error 34, EC\_SEQ\_TIMEOUT Sequencer timeout
- ◆ error 35, EC\_SEQ\_TIMEOUT RECOVERED sequencer timeout
- ◆ error 36, EC\_UNXPCTD\_SEQ\_ERR Unexpected sequencer error
- ◆ error 37, EC\_UNXPCTD\_SEQ\_ERR RECOVERED unexpected seq error
- ◆ error 38, EC\_DATA\_ECC Uncorrect data field ECC error
- ◆ error 39, EC\_DATA\_ECC RECOVERED data field ECC error
- ◆ error 3A, EC\_ON\_FLY\_CORRECTED
- ◆ error 3B, EC\_REC\_DATA\_EQUAL RECOVERED data w/2 = syndromes
- ◆ error 3C, EC\_REC\_DATA\_LAST RECOVERED data ECC last retry
- ◆ error 3D, EC\_EC\_STATUS Invalid error\_code in r/w



SAGUARO

# Saguaro Error Code Summary, Cont

*SG 1.0/2.1*

- ◆ error 3E, EC\_ECC\_UNDER\_WEDGE Unrecovered
- ◆ error 3F, EC\_ECC\_UNDER\_WEDGE Recovered
- ◆ error 40, RW\_NOT\_USED\_3
- ◆ error 41, RW\_NOT\_USED\_4
- ◆ error 42, EC\_RECALING Drive up to speed and recaling
- ◆ error 43, EC\_SPINNING Drive is spinning up
- ◆ error 44, EC\_STOPPED Drive not been told to spin up
- ◆ error 45, EC\_ERASED\_BURST Unrecovered erase C-burst
- ◆ error 46, EC\_ERASED\_BURST RECOVERED erase C-burst
- ◆ error 47, EC\_SERVO\_DEFECT Unrecoverable Servo Defect
- ◆ error 48, EC\_SERVO\_DEFECT RECOVERED Servo Defect
- ◆ error 49, EC\_BAD\_SYNC Unrecoverable Bad servo sync
- ◆ error 4A, EC\_BAD\_SYNC RECOVERED bad servo sync



SAGUARO

# Saguaro Error Code Summary, Cont

*SG 1.0/2.1*

- ◆ error 4B, EC\_BAD\_SAM Unrecoverable Bad SAM
- ◆ error 4C, EC\_BAD\_SAM RECOVERED bad SAM
- ◆ error 4D, EC\_BAD\_TRKNUM\_OR\_INDEX Unrecovered Bad track numb data
- ◆ error 4E, EC\_BAD\_TRKNUM\_OR\_INDEX RECOVERED bad track number data
- ◆ error 4F, EC\_BAD\_HEAD\_SELECT Head from ID != selected head
- ◆ error 50, EC\_BUMPED Unrecoverable Bump
- ◆ error 51, EC\_BUMPED RECOVERED Bump
- ◆ error 52, EC\_BUMP\_TIMEOUT Bump timeout
- ◆ error 53, EC\_BUMP\_TIMEOUT RECOVERED bump timeout
- ◆ error 54, EC\_UNEXPECTED\_TRK\_ID Unrecovrd Gray code != desired
- ◆ error 55, EC\_UNEXPECTED\_TRK\_ID RECOVERED Gray code != desired
- ◆ error 56, EC\_LOST\_LOCK Unrec mult bad Sync/SAM Settle/Ontrk
- ◆ error 57, EC\_LOST\_LOCK RECOVERED mult Sync/SAM Settle/Ontrk



SAGUARO

# Saguaro Error Code Summary, Cont

SG 1.0/2.1

- ◆ error 58, EC\_OUT\_SPEED Unrecoverable Speed out of range
- ◆ error 59, EC\_OUT\_SPEED RECOVERED speed out of range
- ◆ error 5A, EC\_SVO\_STATUS Invalid servo\_status w/err bits set
- ◆ error 5B, EC\_SVO\_STATUS RECOVERED Invalid servo\_status
- ◆ error 5C, SVO\_NOT\_USED\_1
- ◆ error 5D, SVO\_NOT\_USED\_2
- ◆ error 5E, SVO\_NOT\_USED\_3
- ◆ error 5F, SVO\_NOT\_USED\_4
- ◆ error 60, EC\_SEEK\_ERROR Seek error
- ◆ error 61, EC\_SEEK\_ERROR RECOVERED seek error
- ◆ error 62, EC\_SEEK\_TIMEOUT Seek timeout with no servo fault
- ◆ error 63, EC\_SEEK\_TIMEOUT RECOVERED seek timeout w/no svoflt
- ◆ error 64, EC\_SEEK\_LOST\_LOCK Unrec mult bad Sync/SAM SeekISR





# Saguaro Error Code Summary, Cont

*SG 1.0/2.1*

- ◆ error 58, EC\_OUT\_SPEED Unrecoverable Speed out of range
- ◆ error 59, EC\_OUT\_SPEED RECOVERED speed out of range
- ◆ error 5A, EC\_SVO\_STATUS Invalid servo\_status w/err bits set
- ◆ error 5B, EC\_SVO\_STATUS RECOVERED Invalid servo\_status
- ◆ error 5C, SVO\_NOT\_USED\_1
- ◆ error 5D, SVO\_NOT\_USED\_2
- ◆ error 5E, SVO\_NOT\_USED\_3
- ◆ error 5F, SVO\_NOT\_USED\_4
- ◆ error 60, EC\_SEEK\_ERROR Seek error
- ◆ error 61, EC\_SEEK\_ERROR RECOVERED seek error
- ◆ error 62, EC\_SEEK\_TIMEOUT Seek timeout with no servo fault
- ◆ error 63, EC\_SEEK\_TIMEOUT RECOVERED seek timeout w/no svoflt
- ◆ error 64, EC\_SEEK\_LOST\_LOCK Unrec mult bad Sync/SAM SeekISR

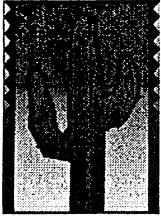

# Saguaro Error Code Summary, Cont

- ◆ error 65, EC\_SEEK\_LOST\_LOCK RECOVERED mult Sync/SAM Seek ISR
- ◆ error 66, SK\_NOT\_USED\_0
- ◆ error 67, SK\_NOT\_USED\_1
- ◆ error 68, EC\_MOTOR\_FAULT Motor unable to get up to speed
- ◆ error 69, EC\_MOTOR\_FAULT RECOVERED motor unable get speed
- ◆ error 6A, EC\_TRK0\_NOT\_FOUND Track 0 not found
- ◆ error 6A, EC\_RCL\_CS\_PES Coarse Slope PES Gain calibration
- ◆ error 6B, EC\_RCL\_CS\_PES RECOVERED Coarse Slope PES calibrat
- ◆ error 6C, EC\_RCL\_AEQBH Fine Slope PES Gain calib AEQBH
- ◆ error 6D, EC\_RCL\_AEQBH RECOVERED Fine Slope PES calib AEQBH
- ◆ error 6E, EC\_RCL\_AEQBL Fine Slope PES Gain calib AEQBL
- ◆ error 6F, EC\_RCL\_AEQBL RECOVERED Fine Slope PES calib AEQBL
- ◆ error 70, EC\_RCL\_ON\_TRACK RCL FLT- Cannot Lock to track



SAGUARO

# Saguaro Error Code Summary, Cont

*SG 1.0/2.1*

- ◆ error 71, EC\_RCL\_ON\_TRACK RECOVERED Cannot Lock to track
- ◆ error 72, EC\_RCL\_NO\_SAM Can't detect SAM during unparking
- ◆ error 73, EC\_RCL\_NO\_SAM RECOVERED detect SAM during unprk
- ◆ error 74, EC\_RCL\_FAIL\_WEDGE\_SYNC Cant sk to wedge sync area
- ◆ error 75, EC\_RCL\_FAIL\_WEDGE\_SYNC\_RECOVERED wedge sync seek
- ◆ error 76, EC\_RCL\_MAP\_HDS Can't detect reliable SAM any head
- ◆ error 77, EC\_RCL\_MAP\_HDS RECOVERED detect SAM on any head
- ◆ error 78, EC\_RCL\_SK\_OD Can't seek to OD near Sys Cyl
- ◆ error 79, EC\_RCL\_SK\_OD RECOVERED seek to OD near Sys Cyl
- ◆ error 7A, EC\_RCL\_SK\_FS\_PES Can't seek Fine Slope PES cal trk
- ◆ error 7B, EC\_RCL\_SK\_FS\_PES RECOVERED seek Fine SLP cal trk
- ◆ error 7C, EC\_RCL\_SK\_NULLI Seek fail during Nulli calibratn

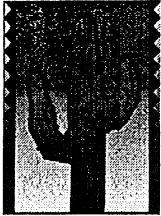

# Saguaro Error Code Summary, Cont

SAGUARO

*SG 1.0/2.1*

- ◆ error 7D, EC\_RCL\_SK\_NULLI RECOVERED Seek during Nulli calib
- ◆ error 7E, EC\_RCL\_SK\_VSCALE Seek fail during V\_SCALE adapt
- ◆ error 7F, EC\_RCL\_SK\_VSCALE RECOVERED Seek in V\_SCALE adapt
- ◆ error 80, EC\_RCL\_SK\_KLOOP Seek failure during KLOOP calibr
- ◆ error 81, EC\_RCL\_SK\_KLOOP RECOVERED Seek during KLOOP calib
- ◆ error 82, EC\_RCL\_SK\_RRO Seek failure during RRO calib
- ◆ error 83, EC\_RCL\_SK\_RRO RECOVERED Seek during RRO calib
- ◆ error 84, EC\_RCL\_SK\_REZERO Seek fail track 0 during rezero
- ◆ error 85, EC\_RCL\_SK\_REZERO RECOVERED Seek tk0 during rezero
- ◆ error 86, EC\_RCL\_KLOOP Unable to complete KLOOP calibrat
- ◆ error 87, EC\_RCL\_KLOOP RECOVERED to complete KLOOP calib
- ◆ error 88, EC\_RCL\_RRO Unable to complete RRO calibratn
- ◆ error 89, EC\_RCL\_RRO RECOVERED to complete RRO calib



SAGUARO

# Saguaro Error Code Summary, Cont

*SG 1.0/2.1*

- ◆ error 8A, EC\_RCL\_LOCK\_SAM Unable to lock TNA in OD unpark
- ◆ error 8B, EC\_RCL\_LOCK\_SAM RECOVERED lock TNA in OD unpark
- ◆ error 8C, EC\_RCL\_UNPRK\_TRK\_TOUT TNA lock tout wait unpk trk
- ◆ error 8D, EC\_RCL\_UNPRK\_TRK\_TOUT RECOVERED found unpark track
- ◆ error 8E, EC\_RCL\_CANT\_READ\_TRK TNA lock, trkid fail unpktrk
- ◆ error 8F, EC\_RCL\_CANT\_READ\_TRK RECOVERED trk id while unprk
- ◆ error 90, EC\_RCL\_CANT\_STOP\_VCM VCM too fast.
- ◆ error 91, EC\_RCL\_CANT\_STOP\_VCM RECOVERED VCM too fast
- ◆ error 92, RCL\_NOT\_USED\_0
- ◆ error 93, RCL\_NOT\_USED\_1
- ◆ error 94, RCL\_NOT\_USED\_2
- ◆ error 95, RCL\_NOT\_USED\_3
- ◆ error 96, RCL\_NOT\_USED\_4



SAGUARO

# Saguaro Error Code Summary, Cont

*SG 1.0/2.1*

- ◆ error 97, EC\_PARAMETER\_OVR Parameter overrun
- ◆ error 98, EC\_SCSI\_PARITY SCSI Bus parity error
- ◆ error 99, EC\_MODE\_CHANGED Mode select parameters changed
- ◆ error 9A, EC\_TARGET\_RE\_SELECT A target attempted re-select
- ◆ error 9B, EC\_SYNC\_XFER Synchronous transfer error
- ◆ error 9C, EC\_INV\_SYNC\_PARMS Inval period/offst in sync msg
- ◆ error 9D, EC\_ACTIVE\_SELECT Active initor slct while discon
- ◆ error 9E, EC\_INV\_LUN Invalid lun specified
- ◆ error 9F, EC\_MSG\_REJECT Message reject error
- ◆ error A0, EC\_RESELECT\_TIMEOUT Initiator did not reselect
- ◆ error A1, EC\_INIT\_DET\_ERR Initiator detected error
- ◆ error A2, EC\_FIRMWARE\_1 Rejct msg shld never been sent



SAGUARO

# Saguaro Error Code Summary, Cont

*SG 1.0/2.1*

- ◆ error A3, EC\_ABORT\_MSG Response for an Abort message
- ◆ error A4, EC\_DOUBLE\_SELECT Attempt select drive 2nd time
- ◆ error A5, EC\_UNXPCT\_SIC\_INT Unexpected SIC interrupt
- ◆ error A6, EC\_SYNC\_REQ\_ACK Synchronous acknowledge error
- ◆ error A7, EC\_SYNC\_ACK Synchronous acknowledge error
- ◆ error A8, EC\_SIC Undocumented SIC error
- ◆ error A9, EC\_FIFO\_LOAD Undocumented SIC error
- ◆ error AA, EC\_FIFO\_UNLOAD Undocumented SIC error
- ◆ error AB, EC\_FIFO\_PRED\_FULL Undocumented SIC error
- ◆ error AC, EC\_RAM\_PARITY Undocumented SIC error
- ◆ error AD, EC\_MED\_FMT\_CORRPT Undocumented SIC error
- ◆ error AE, EC\_NA\_COMMAND Undocumented SIC error
- ◆ error AF, EC\_BURN\_IN\_TEST Undocumented SIC error



**SAGUARO**

# PCB & READ/WRITE



*SG 1.0/2.1*

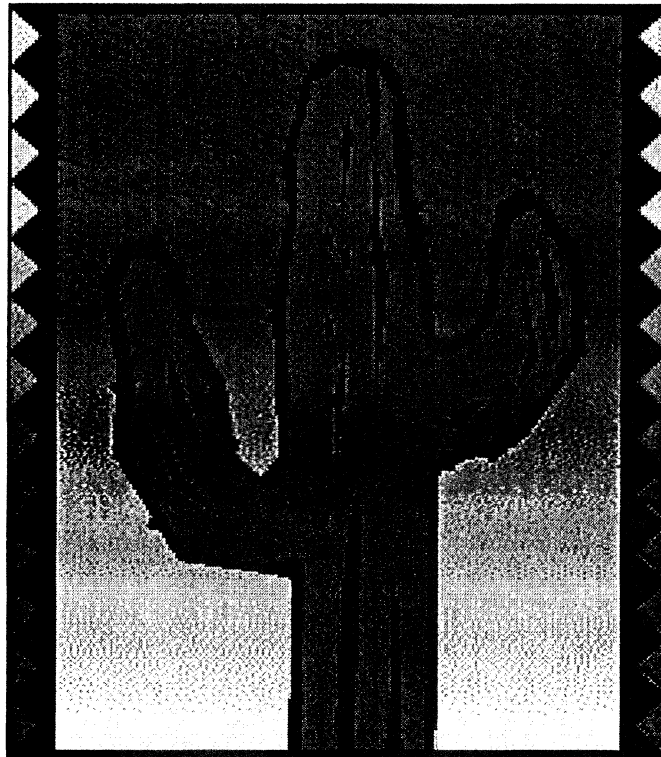

# SAGUARO





# PCB Block Diagram

SAGUARO

SG 1.0/2.1

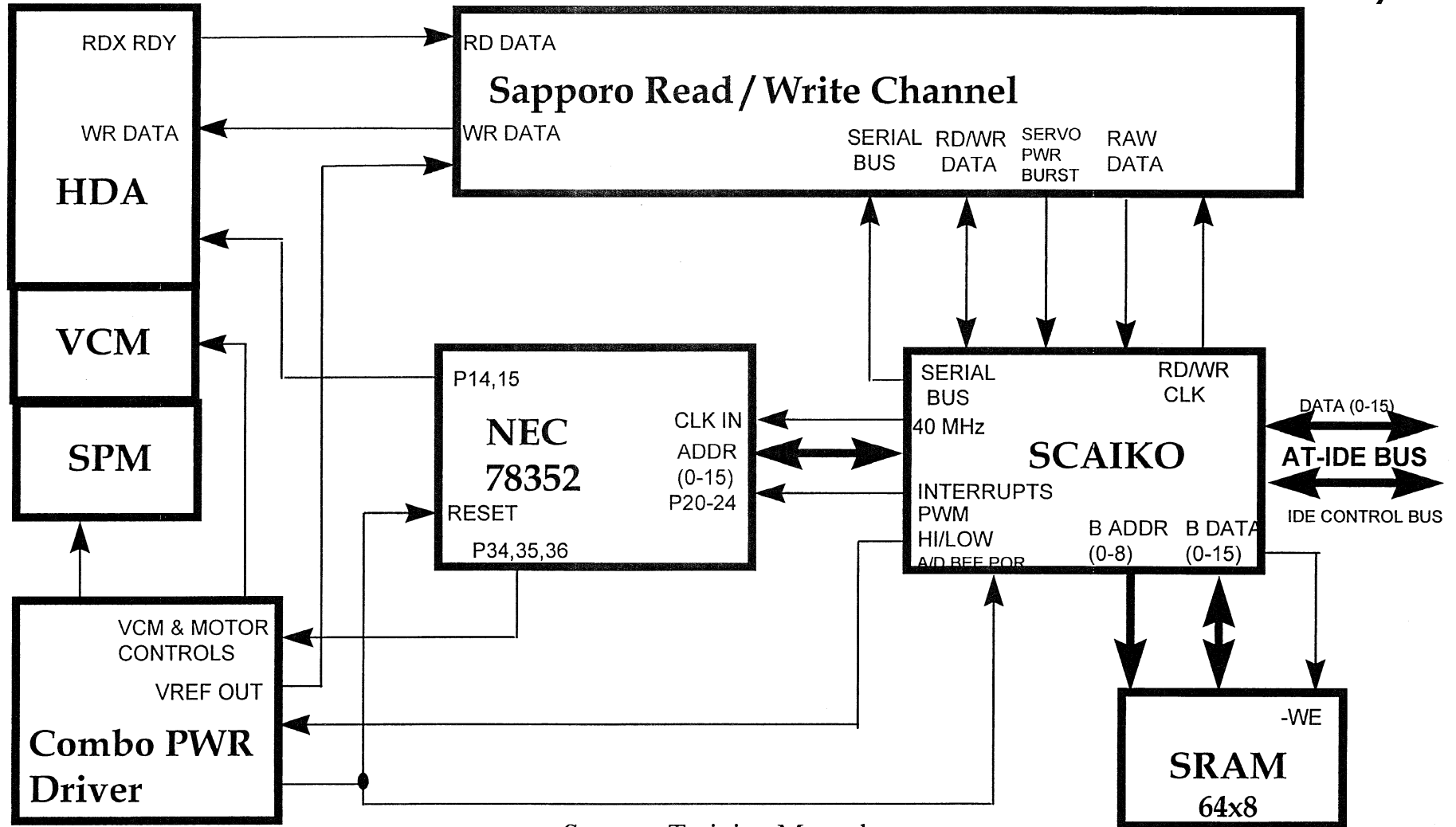

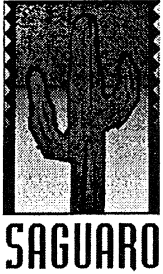

# SAGUARO READ/WRITE CHANNEL

## TRAINED PARAMETERS

SG 1.0/2.1

- ◆ WRITE CURRENT.
- ◆ WRITE PRECOMP.
- ◆ BOOST.
- ◆ BANDWIDTH.
- ◆ ZPR.
- ◆ OFFSET.
- ◆ VGA.
- ◆ PTF.
- ◆ FIR



SAGUARO

# Track Format

SG 1.0/2.1

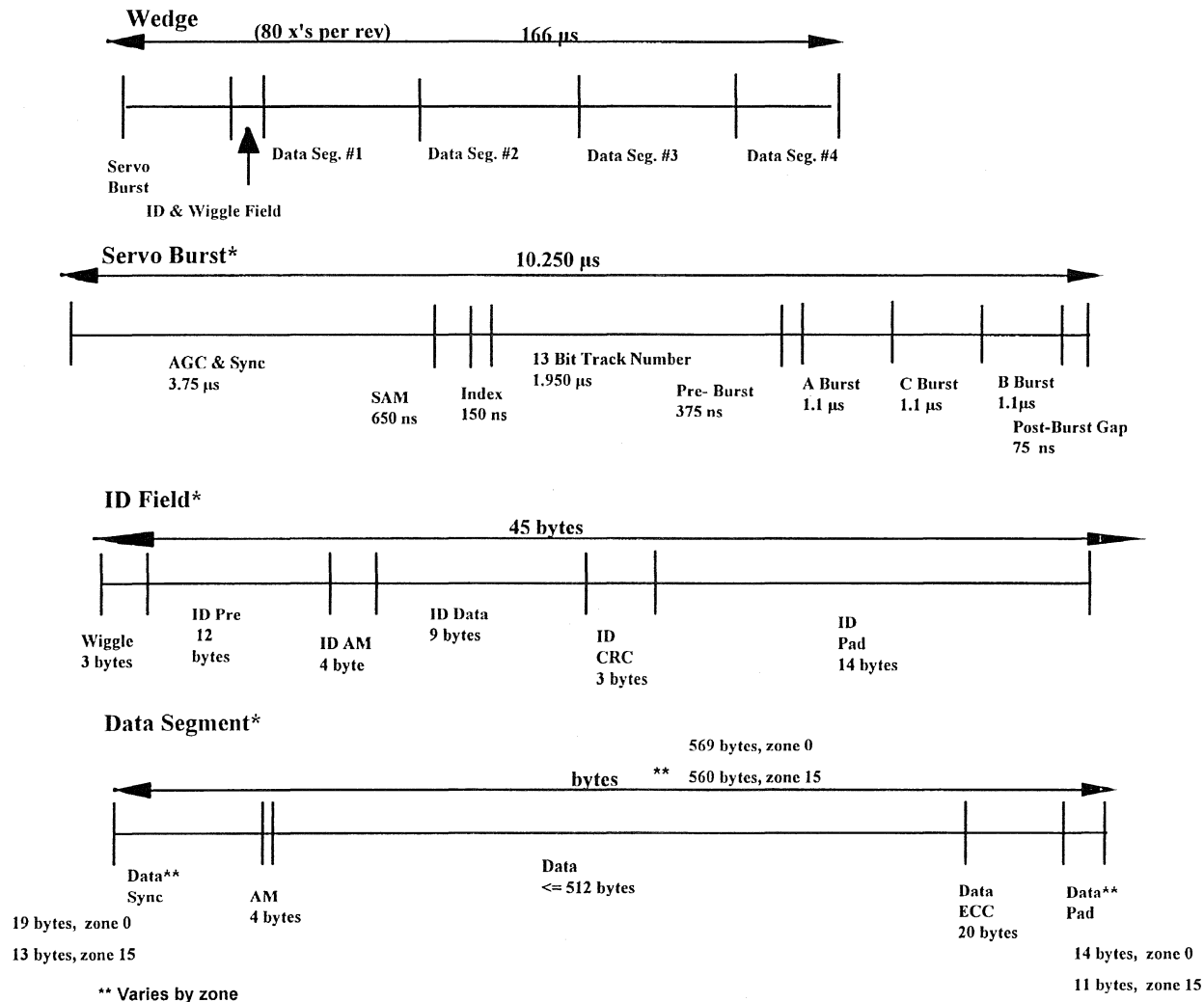

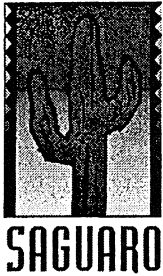

# Zone Specifications

SG 1.0/2.1

Zone Number	Zone Outside Radius	Zone Inner Radius	No. Cyl	Sectors Per Track	Sectors Per Zone	Bytes Per Sector	Data Rate (Mb/Sec)	Write Clock (MHz)	Fmax (Sine) (MHz)	Wdw/2 (nSec)
System	1.7777	1.7756	12	200	2400	512	76.64	81.43	20.36	12.28
0	1.7756	1.7046	401	266	106666	512	100.39	106.67	26.67	9.38
1	1.7046	1.6408	361	256	92416	512	96.81	102.86	25.71	9.72
2	1.6408	1.5625	442	245	108290	512	92.41	98.18	24.55	10.19
3	1.5625	1.5020	342	240	82080	512	88.98	94.55	23.64	10.58
4	1.5020	1.4544	269	228	61332	512	86.27	91.67	22.92	10.91
5	1.4544	1.3972	323	220	71060	512	82.99	88.18	22.05	11.34
6	1.3972	1.3252	407	208	84656	512	78.78	83.70	20.93	11.95
7	1.3252	1.2664	332	200	66400	512	75.29	80.00	20.00	12.50
8	1.2664	1.2142	295	190	56050	512	72.16	76.67	19.17	13.04
9	1.2142	1.1512	356	180	64080	512	68.36	72.63	18.16	13.77
10	1.1512	1.0942	322	170	54740	512	64.91	68.97	17.24	14.50
11	1.0942	1.0087	483	160	77280	512	59.70	63.43	15.86	15.77
12	1.0087	0.9700	219	150	32850	512	57.33	60.91	15.23	16.42
13	0.9700	0.9089	345	140	48300	512	53.57	56.92	14.23	17.57
14	0.9089	0.8696	222	133	29526	512	51.15	54.35	13.59	18.40
15	0.8696	0.8321	212	125	26500	512	48.67	51.71	12.93	19.34

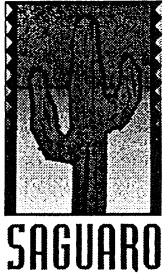

# SCAIKO-A ASIC MAIN BLOCKS

*SG 1.0/2.1*

- ◆ HOST INTERFACE.
- ◆ BUFFER CONTROL.
- ◆ MOTOR/VCM INTERFACE.
- ◆ SERVO CONTROL.
- ◆ SERIAL INTERFACE.
- ◆ MICROPROCESSOR INTERFACE.
- ◆ SEQUENCER CONTROL.
- ◆ ERROR CORRECTION CONTROL.
- ◆ TIME STAMP.

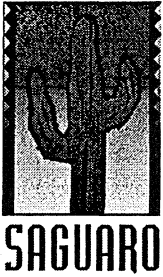

# MICROCONTROLLER

*SG 1.0/2.1*

THE NEC UP78352 IS A MEMBER OF THE K-SERIES OF MICROCONTROLLER.

- ◆ 40 MHZ CLOCK OPERATION.
- ◆ BUILD-IN ROM 32K X 8 BITS.
- ◆ BUILD-IN RAM 640 X 8 BITS.

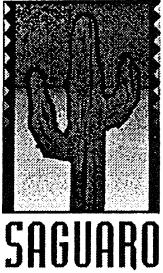

# PREAMP

SG 1.0/2.1

## VTC AND HITACHI 4-CHANNEL PREAMPLIFIER

- ◆ READ GAIN 300 V/V +/- 17%.
- ◆ BANDWIDTH OF HITACHI 85 MHZ.
- ◆ BANDWIDTH OF VTC 65 MHZ.
- ◆ INPUT NOISE 0.52 nV/ HZ.
- ◆ WRITE CURRENT RANGE 2-15 mA.
- ◆ INPUT CAPACITANCE 10PF.
- ◆ SINGLE POWER SUPPLY +5V.
- ◆ LOW POWER 200mW.

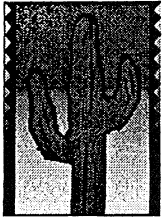

**SAGUARO**

# SRAM

*SG 1.0/2.1*

- ◆ 25ns 64K X 8 SRAM.
- ◆ 24.5 Mbytes/Sec. MAXIMUM BUFFER BANDWIDTH
- ◆ 12 WORD FIFOs FOR THE HOST.
- ◆ 12 WORD FIFOs FOR THE DISK INTERFACE.
- ◆ 4 WORD PREFETCH FOR UP CODE



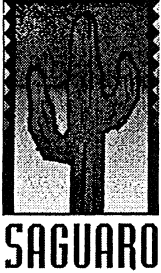

# MOTOR/VCM

*SG 1.0/2.1*

COMBO (HA13555F) INCLUDES THE VCM DRIVER AND THE SPINDLE MOTOR DRIVER.

– THIS IS A DIE-SHRINK VERSION OF THE HA13545F COMBO.

◆ DYNAMIC BRAKING FOR NON-POWER DOWN MODE.

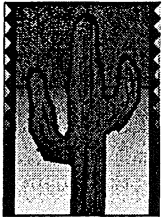

SAGUARO

# MOTOR/VCM, Cont

*SG 1.0/2.1*

- ◆ 1.8 A MAX 3 PHASE MOTOR DRIVER
  - 900mA MAX
- ◆ 1.2 A MAX VCM DRIVER
  - 600mA MAX
- ◆ SOFT SWITCHING SPINDLE DRIVE.
- ◆ POR MONITORS BOTH 5V AND 12V SUPPLY.
- ◆ AUTO-PARK IN CASE OF POWER DOWN.
- ◆ SPEED DISCRIMINATION.



**SAGUARO**

# Sapporo Block Diagram

*SG 1.0/2.1*

Refer to Training Manual  
for the Block Diagram

# Sapporo Block Diagram

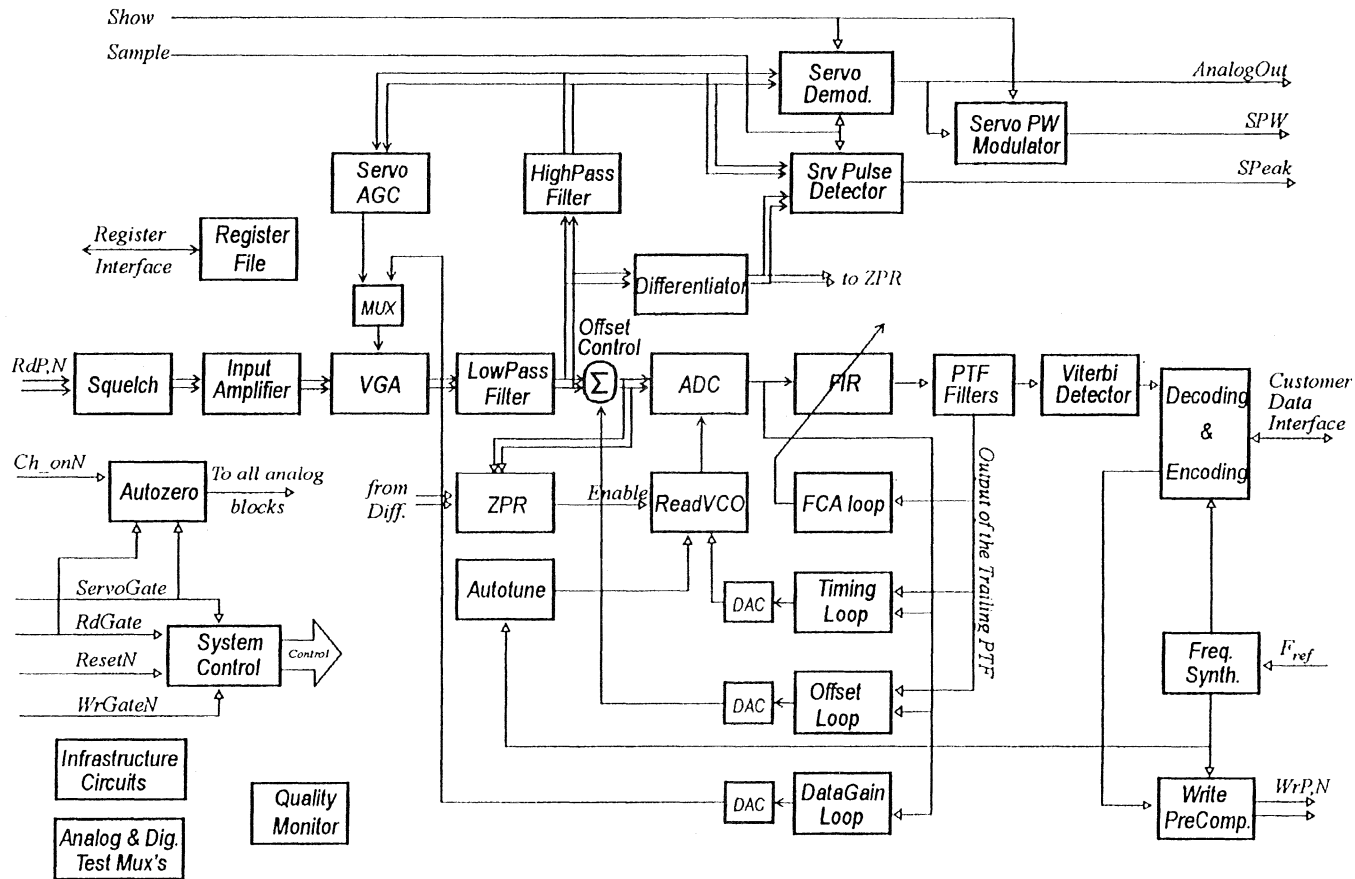



# SAPPORO READ/WRITE CHANNEL

*SG 1.0/2.1*

- ◆ SAPPORO IS A SINGLE-CHIP PR4 RD/WR CHANNEL CUSTOM-DESIGNED BY
  - QUANTUM AND CIRRUS LOGIC.
- ◆ MAXIMUM CUSTOMER DATA RATE
  - 115Mbps.
- ◆ 16/17 CHANNEL CODE.

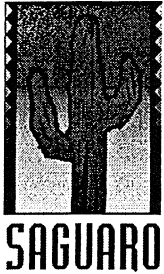

# SAPPORO READ/WRITE CHANNEL

*SG 1.0/2.1*

- ◆ 0.6 MICRON CMOS PROCESS WITH 3-LAYER METAL.
- ◆ ANALOG FRONT-END AND DIGITAL BACK-END IMPLEMENTATION.
- ◆ SINGLE SUPPLY VOLTAGE +5V.
- ◆ POWER MAXIMUM 2W, FLEXIBLE POWER CONTROL



# AT Pump

*SG 1.0/2.1*

Refer to Training Manual  
for the  
AT Pump Assembly Drawing

SAGUARO AT PMP  
Assembly Drawing

10-111584-04 REV A

Last Edit 10/15/96

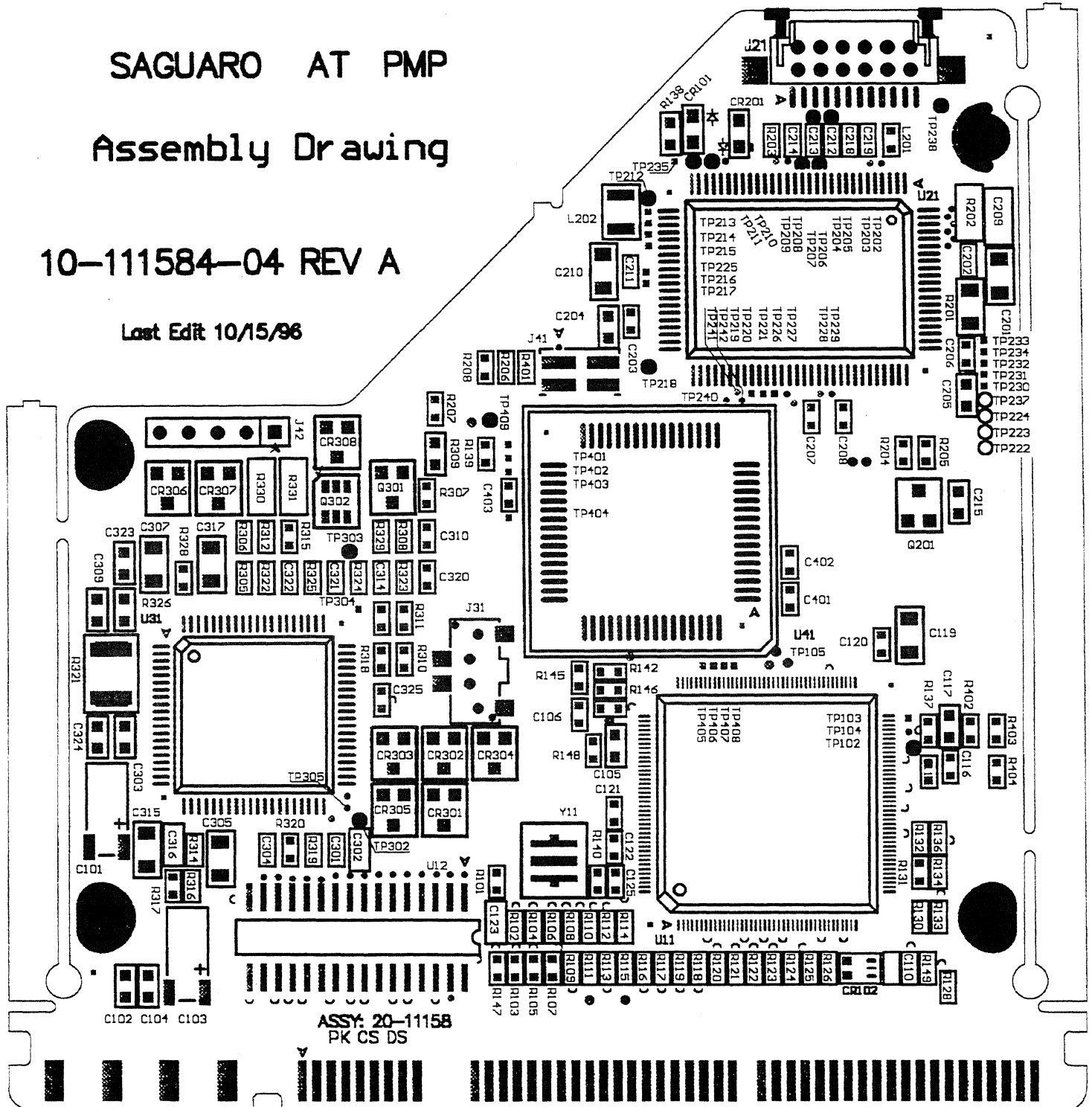



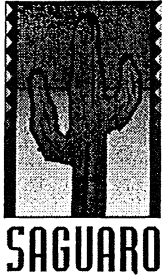

# Saguaro Bill of Materials

*SG 1.0/2.1*

Refer to Training Manual  
for the BOM

Item	Quantity	Reference	Part
1	1	CR101	LED,0805,GRN
2	1	CR102	UMN1N,UM5,
3	1	CR201	1SS355,USM,
4	1	CR301	HSM221C,SOT23,
5	6	CR302,CR303,CR304,CR306, CR307,CR308	HRW0503A,SOT23,
6	1	CR305	DAN202K,SOT23,
7	2	C101,C103	15uF,FCB8,ELECT
8	10	C102,C104,C105,C123,C204, C205,C215,C303,C323,C324	1uF,0805,Y5V
9	1	C106	.01uF,0603,X7R
10	11	C107,C110,C120,C125,C211, C212,C213,C310,C320,C321, C322	1000pF,0603,X7R
11	11	C115,C121,C122,C202,C203, C206,C207,C208,C401,C402, C403	.1uF,0603,Y5V
12	1	C116	3300pF,0603,X7R
13	1	C117	.033uF,0805,X7R
14	2	C119,C315	1uF,1206,X7R
15	2	C210,C201	4.7uF,1206,Y5V
16	4	C209,C305,C307,C317	2.2uF,1206,Y5V
17	1	C214	150pF,0603,CH
18	2	C218,C219	2200pF,0603,X7R
19	2	C301,C304	.22uF,0603,Y5V
20	1	C302	.056uF,0805,X7R
21	1	C309	.1uF,0805,Y5V
22	1	C314	1800pF,0603,X7R
23	1	C316	.1uF,0805,X7R
24	5	J41,J42,R143,R207,C325	TBD,,
25	1	J11	CONN AT/JP/DC,LP,
26	1	J21	CONN R/W,12P,BC
27	1	J31	CONN MTR,SMT,LP
28	1	L201	IMPEDER,0603,601B
29	1	L202	10uH,1210,
30	1	Q201	DTA114EK,SOT23,
31	1	Q301	2SC3325,SOT23,
32	1	Q302	1MT17,SOT36,
33	13	R101,R119,R123,R124,R130, R136,R139,R308,R329,R401, R402,R403,R404	10K,0603,5%
34	18	R102,R103,R104,R105,R106, R107,R108,R109,R110,R111, R112,R113,R114,R115,R116, R117,R118,R126	33 ohm,0603,5%
35	10	R120,R121,R125,R128,R131, R132,R133,R134,R147,R203	82 ohm,0603,5%
36	2	R122,R315	0 ohm,,
37	1	R137	40.2 ohm,0603,1%
38	2	R138,R309	220 ohm,0805,5%
39	2	R140,R142	1M,0603,5%
40	1	R145	332 ohm,0603,1%
41	1	R146	47.5K,0603,1%
42	1	R148	10 ohm,0603,5%
43	1	R149	430 ohm,0603,5%
44	4	R201,R202,R330,R331	2.0 ohm,1206,5%
45	2	R204,R205	2.55K,0603,1%
46	2	R208,R206	1.0K,0603,5%
47	1	R305	35.7K,0603,1%

48	1	R306	5.90K,0603,1%
49	2	R311,R307	5.62K,0603,1%
50	1	R310	182K,0603,1%
51	1	R312	16.5K,0603,1%
52	1	R313	22 ohm,0603,5%
53	1	R314	7.15K,0603,1%
54	1	R316	2.80K,0603,1%
55	1	R317	110K,0603,5%
56	1	R318	5.6K,0603,5%
57	1	R319	2.61K,0603,1%
58	1	R320	1.21K,0603,1%
59	1	R321	.33 OHM,2010,1/2W 2%
60	1	R322	5.23K,0603,1%
61	1	R323	5.36K,0603,1%
62	2	R324,R325	3.92K,0603,1%
63	1	R326	130 ohm,0805,5%
64	1	R328	47K,0603,5%
65	58	TP102,TP103,TP104,TP105, TP201,TP202,TP203,TP204, TP205,TP206,TP207,TP208, TP209,TP210,TP211,TP212, TP213,TP214,TP215,TP216, TP217,TP218,TP219,TP220, TP221,TP222,TP223,TP224, TP225,TP226,TP227,TP228, TP229,TP230,TP231,TP232, TP233,TP234,TP235,TP237, TP238,TP240,TP241,TP242, TP301,TP302,TP303,TP304, TP305,TP401,TP402,TP403, TP404,TP405,TP406,TP407, TP408,TP409	TESTPOINT,,
66	1	U11	SCAIKO-AT,F64652B,
67	1	U12	SRAM64KX8,SOJ32,
68	1	U21	SAPPORO,QFP100,VH
69	1	U31	HA13555F,QFP80,V1
70	1	U41	UP78352G,-20-22,
71	1	Y11	40MHz,CCR40.0MC6,



SAGUARO

# Schematics

*SG 1.0/2.1*

Refer to Training Manual  
for the Schematics

NOTES:  
 (1) DO NOT INSTALL DISK CONTROLLER/AT INTERFACE  
 (2) NO PARTS, JUMPER TRACE ON THE BOARD  
 (3) R102-R118 ARE RES 33 OHM 0603 5X

FILE: SAGPMP1.SCH

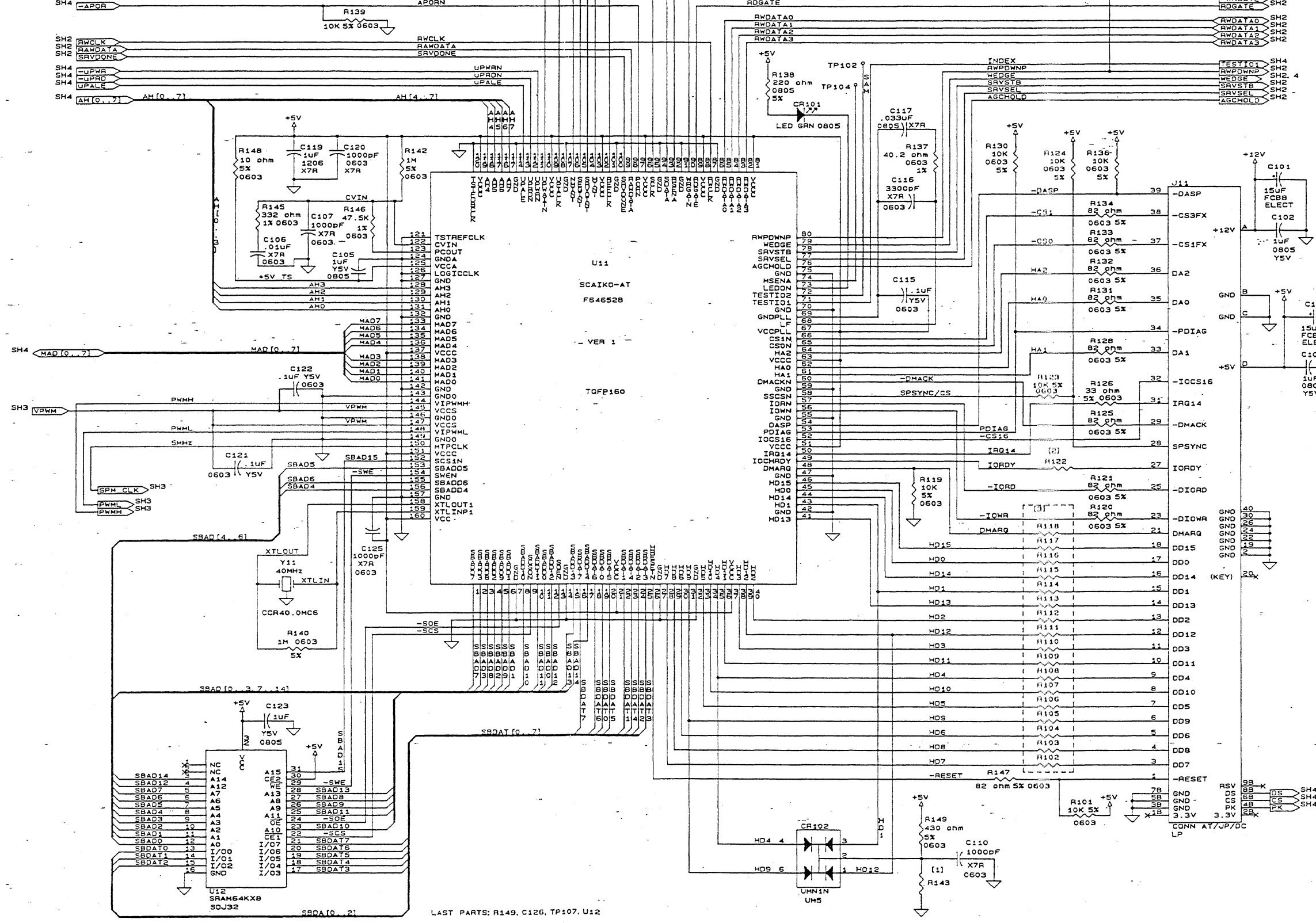

REV	EC	DATE	CK	SIGN

NOTICE OF PROPRIETARY PROPERTY  
 THE INFORMATION CONTAINED HEREIN IS THE PROPERTY OF QUANTUM THE POSSESSOR AGREES TO MAINTAIN THIS DOCUMENT IN CONFIDENCE. NOT TO REPRODUCE, COPY, REVEAL OR PUBLISH IT IN WHOLE OR PART

METRIC  
 TOLERANCES IN MILLIMETERS  
 THIRD ANGLE PROJECTION

LINEAR	≤ 4	± 0.10
	> 4 ≤ 16	± 0.20
	> 16 ≤ 63	± 0.30
	> 63 ≤ 250	± 0.50
	> 250	± 0.80
ANGULAR		± 1°

MATERIAL

FINISH

DRAWN BY DATE  
 10/15/96

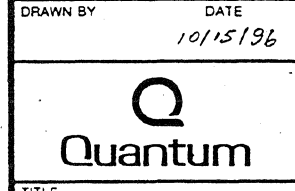

TITLE  
 SAGUARO  
 PMP

SIZE SCALE SHEET  
 C 1 of 4

PART NUMBER REV  
 80-111584-04 1.0

D  
C  
B  
A

LAST PARTS: R149, C126, TP107, U12

NOTES:

[1] DO NOT INSTALL  
FILE: SAGPMP4.SCH

MICROCOTROLLER

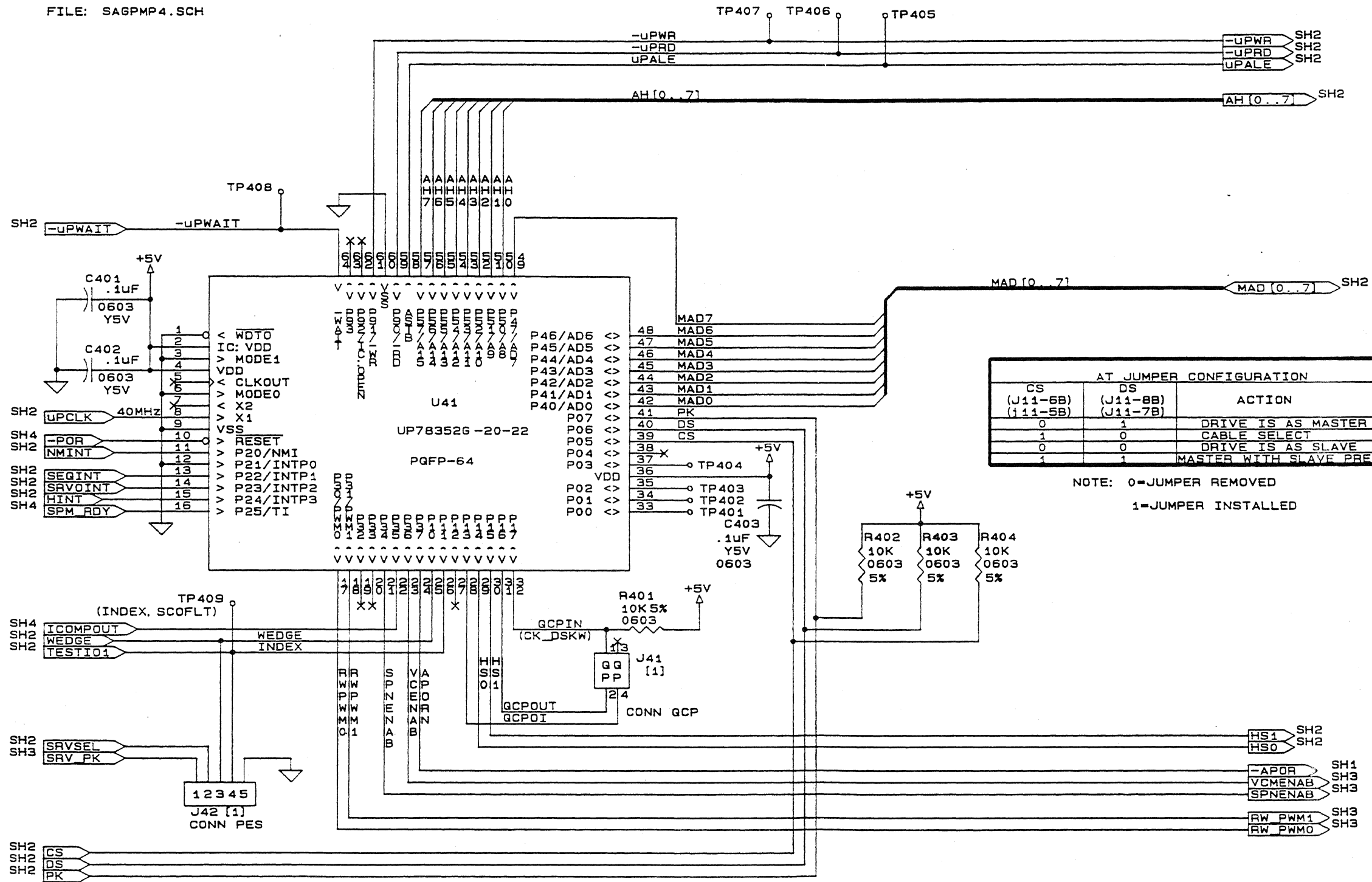

AT JUMPER CONFIGURATION		
CS (J11-6B) (J11-5B)	DS (J11-8B) (J11-7B)	ACTION
0	1	DRIVE IS AS MASTER
1	0	CABLE SELECT
0	0	DRIVE IS AS SLAVE
1	1	MASTER WITH SLAVE PRESENT

NOTE: 0=JUMPER REMOVED  
1=JUMPER INSTALLED

REV	EC	DATE	CK	SIGN

NOTICE OF PROPRIETARY PROPERTY  
THE INFORMATION CONTAINED HEREIN IS THE PROPERTY OF QUANTUM. THE POSSESSOR AGREES TO MAINTAIN THIS DOCUMENT IN CONFIDENCE. NOT TO REPRODUCE, COPY, REVEAL OR PUBLISH IT IN WHOLE OR PART.

METRIC TOLERANCES IN MILLIMETERS THIRD ANGLE PROJECTION		
LINEAR	≤ 4	± 0.10
	> 4 ≤ 16	± 0.20
	> 16 ≤ 63	± 0.30
	> 63 ≤ 250	± 0.50
	> 250	± 0.80
ANGULAR		± 1°

MATERIAL  
FINISH

DRAWN BY DATE  
10/15/96



TITLE  
SAGUARO  
PMP

SIZE	SCALE	SHEET
B		4 OF 4
PART NUMBER	REV	
80-111584-04	1.0	

NOTES:

- (1) DO NOT INSTALL
  - (2) NO PART. JUMPER TRACE ON THE BOARD
- FILE: SAGPMP2.SCH

READ/WRITE

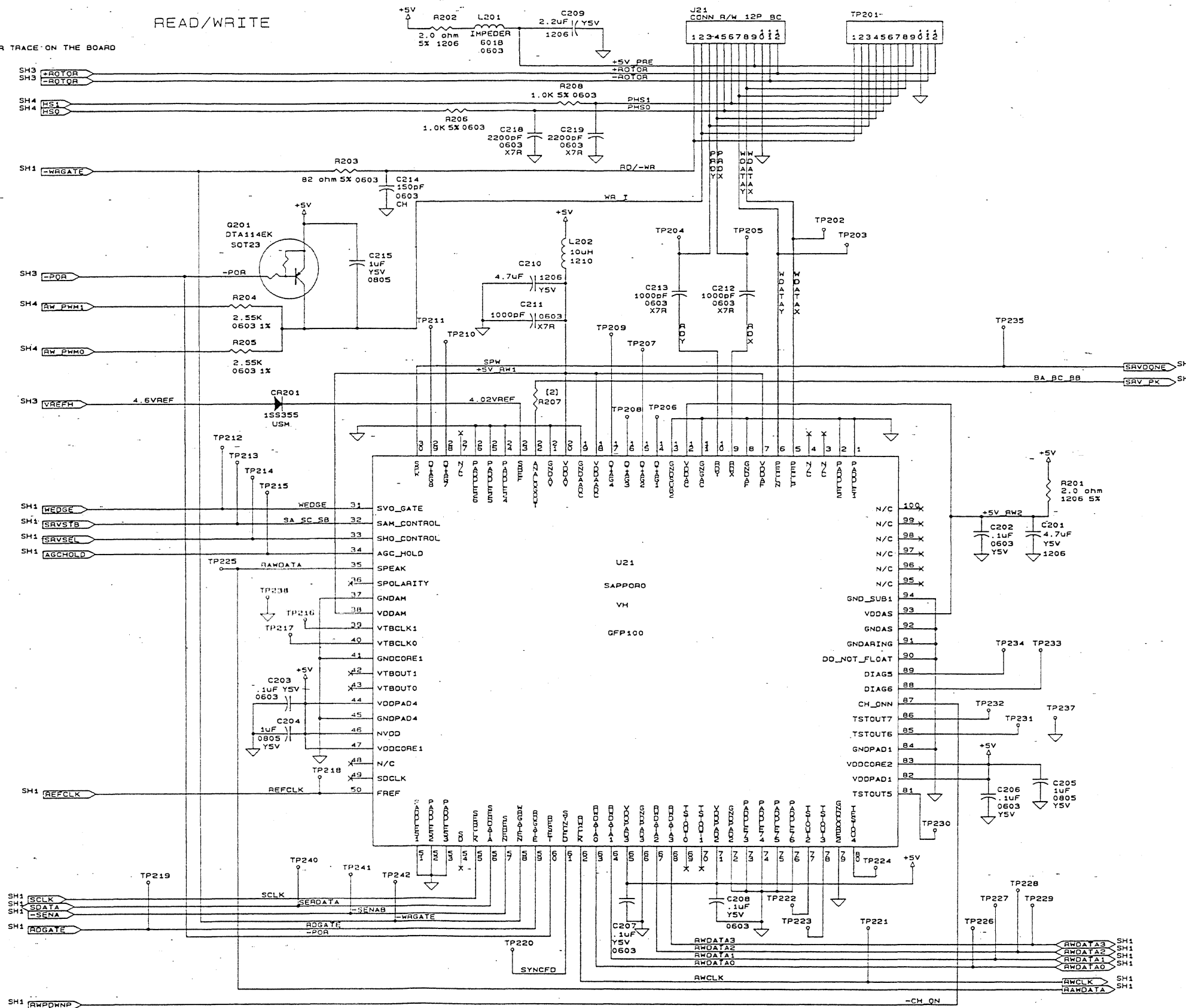

REV	EC	DATE	CK	IGN

NOTICE OF PROPRIETARY PROPERTY  
 THE INFORMATION CONTAINED HEREIN IS THE PROPERTY OF QUANTUM. THE POSSESSOR AGREES TO MAINTAIN THIS DOCUMENT IN CONFIDENCE, NOT TO REPRODUCE, COPY, REVEAL OR PUBLISH IT IN WHOLE OR PART.

**METRIC**  
 TOLERANCES IN MILLIMETER  
 THIRD ANGLE PROJECTION

LINEAR	≤ 4	± 0.10
	> 4	≤ 16 ± 0.20
	> 16	≤ 63 ± 0.30
	> 63	≤ 250 ± 0.50
	> 250	± 0.80
ANGULAR		± 1°

MATERIAL  
 FINISH

DRAWN BY DATE  
 10/15/94



TITLE  
 SAGUARO PMP

SIZE SCALE SHEET  
 C 2 OF 4

PART NUMBER REV  
 80-111584-04

D

C

B

A

4

3

2

1

NOTES:

- [1] DO NOT INSTALL
  - [2] NO PART. JUMPER TRACE ON THE BOARD
- FILE : SAGPMP3.SCH

MOTOR/VCM

REV	EC	DATE	CK	SIGN

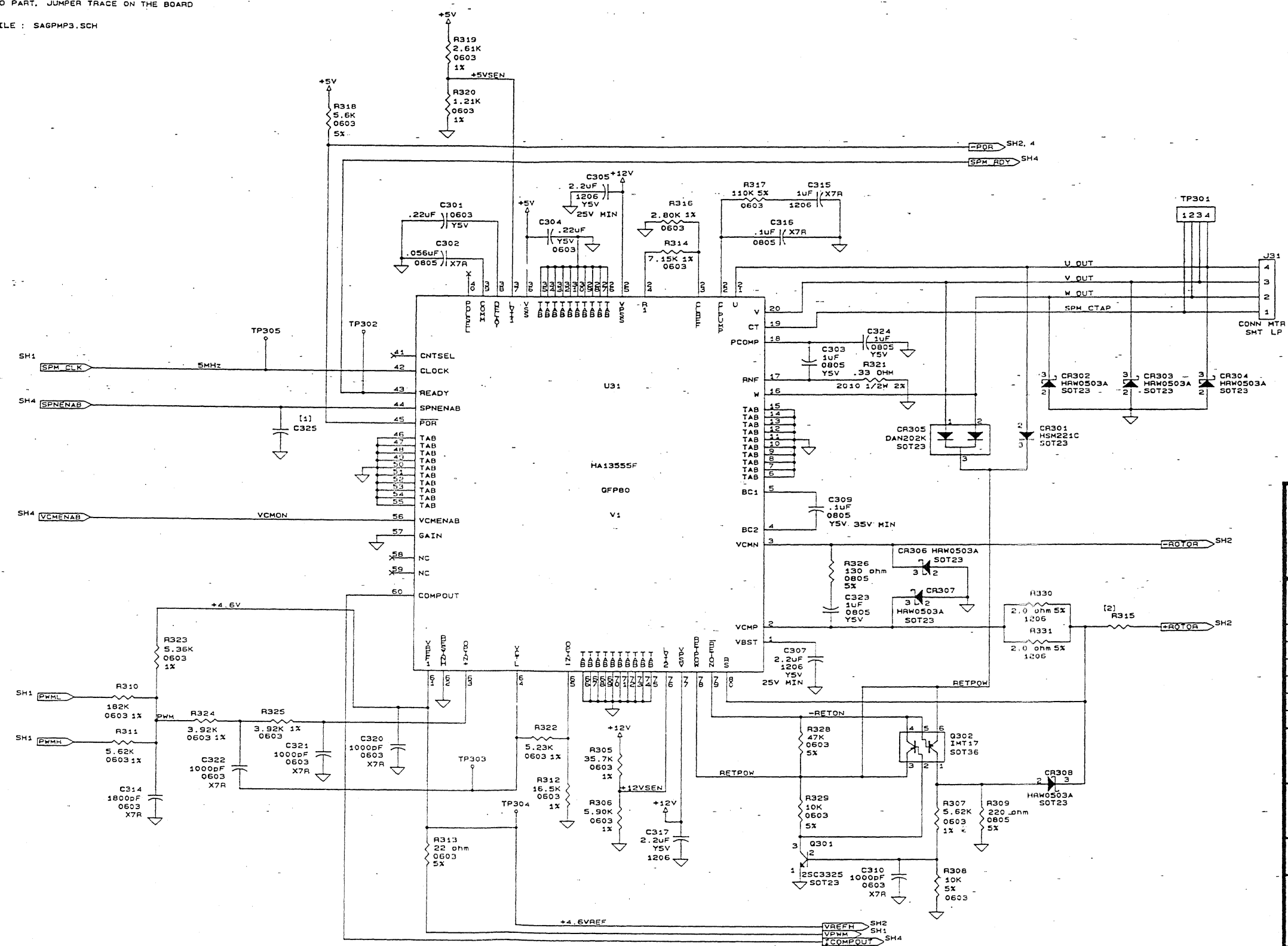

NOTICE OF PROPRIETARY PROPERTY  
 THE INFORMATION CONTAINED HEREIN  
 IS THE PROPERTY OF QUANTUM THE  
 POSSESSOR AGREES TO MAINTAIN  
 THIS DOCUMENT IN CONFIDENCE. NOT  
 TO REPRODUCE, COPY REVEAL OR  
 PUBLISH IT IN WHOLE OR PART

METRIC TOLERANCES IN MILLIMETERS THIRD ANGLE PROJECTION		
LINEAR	≤ 4	± 0.10
	> 4 ≤ 16	± 0.20
	> 16 ≤ 63	± 0.30
	> 63 ≤ 250	± 0.50
	> 250	± 0.80
ANGULAR		± 1°

MATERIAL  
  
 FINISH

DRAWN BY DATE  
 10/15/94

**Quantum**  
 TITLE  
 SAGUARO  
 PMP

SIZE	SCALE	SHEET
C		3 OF 4
PART NUMBER		REV





**SAGUARO**

*Saguaro* **SERVO** October 1996



*SG 1.0/2.1*



**SAGUARO**



SAGUARO

# Servo Related Parameters

*SG 1.0/2.1*

- ◆ TPI
  - 5650
- ◆ Track Pitch
  - 177 ui
- ◆ Number of Cylinders
  - 5330
- ◆ Disk Rotation Speed
  - 4500 rpm
- ◆ Servo samples/rev
  - 80
- ◆ Servo sample freq
  - 6.00 KHz
- ◆ Servo sample time
  - 167 usec
- ◆ Servo-mech loop bandwidth
  - 450Hz



# Servo Changes

*SG 1.0/2.1*

	<u><i>Trbl</i></u>	<u><i>Saguaro</i></u>
◆ TPI	3794	5650
◆ Number of Cylinders	3653	5330
◆ On track BW (Hz)	350	450
◆ Max Head Velocity (ips)	120	135
◆ Sequential Seek (ms)	4.0	3.5
◆ Sequential Head Sw (ms)	3.0	2.5



# Servo Changes, Cont

SG 1.0/2.1

	<u>Trbl</u>	<u>Saguaro</u>
◆ Random Seek time (ms)	14	12
◆ Seek acoustics limiting	Yes	Yes
◆ Adaptive RRO calibration	No	Yes
◆ Loop Gain calibration	No	Yes
◆ Arm Radius (cm)	5.44	5.21
◆ Inertia (gm-cm <sup>2</sup> )		
⇒ 1 disk	36.5	25.7
⇒ 2 disk	38.5	30.7



# Servo Changes, Cont

SG 1.0/2.1

	<u>Trbl</u>	<u>Saguaro</u>
◆ Torque K (gf-cm/amp)		
⇒ 1 disk	590	516
⇒ 2 disk	590	620
◆ Coil Resistance (ohms)	18.0	17.5
◆ Notch Center Freq (KHz)	3.8	5.5
-(To attenuate system mode)		
◆ Spindle RPM	4500	4500
◆ Wedges per rev	63	80
◆ Sample frequency (KHz)	4.73	6.00



# Servo Changes, Cont



	<u>Trbl</u>	<u>Saguaro</u>	SG 1.0/2.1
◆ Sample time (usec)	212	167	
◆ uP speed (MHz)	40	40	
◆ On track ISR time (usec)	80	90	
- as % of $T_s$	38%	54%	
◆ Seek ISR time (usec)	160	135	
- as % of $T_s$	75%	81%	

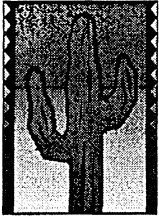

SAGUARO

# 1 disk P2 Rand Ave

---

*SG 1.0/2.1*

See Saguaro Training  
Manual for graph

avg\_Hist4 Chart 1

1d P2 RAND Ave

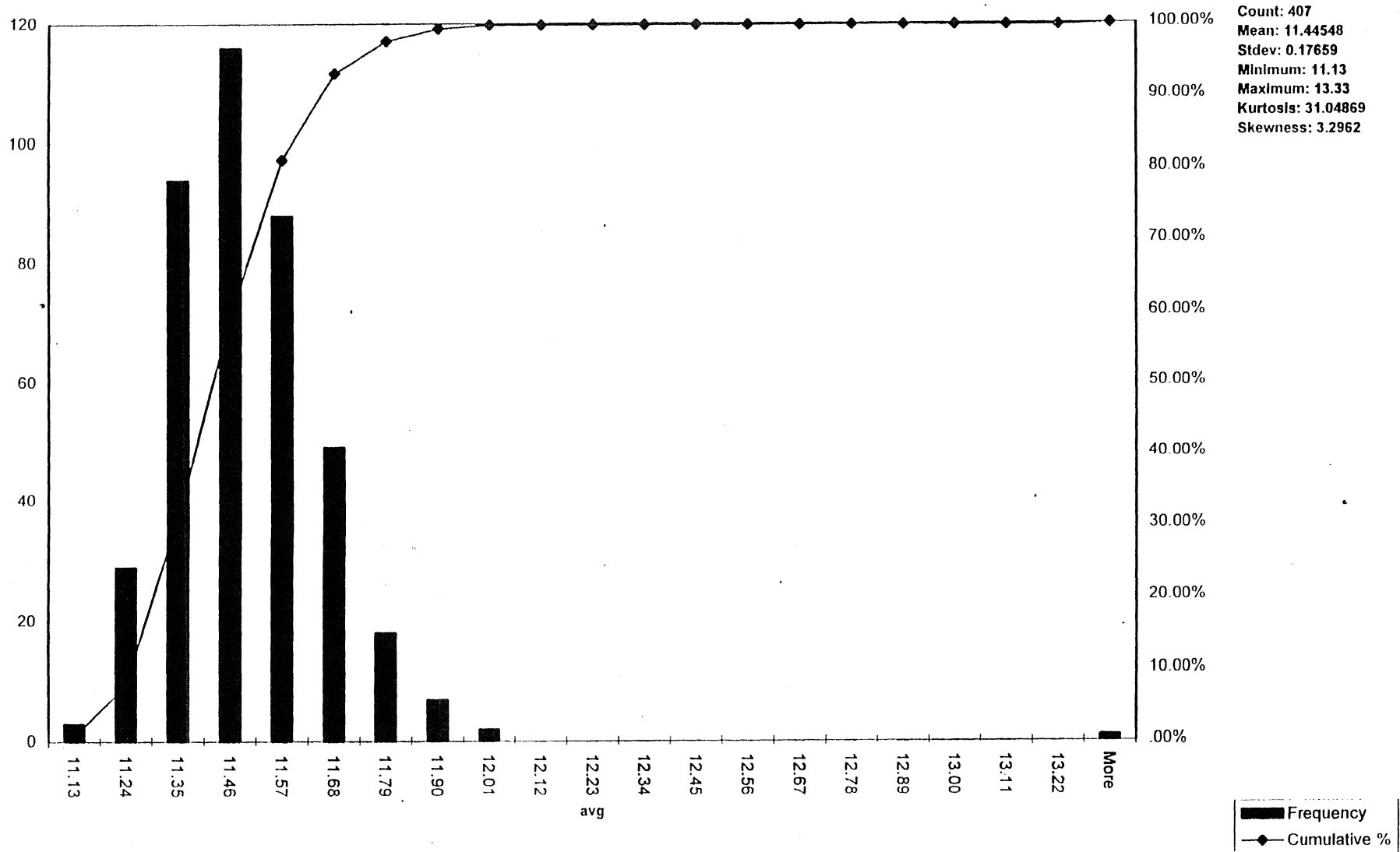





SAGUARO

# 2 disk P2 Rand Ave

---

*SG 1.0/2.1*

See Saguaro Training  
Manual for graph

ave\_Hist1 Chart 1

2d P2 RAND Ave

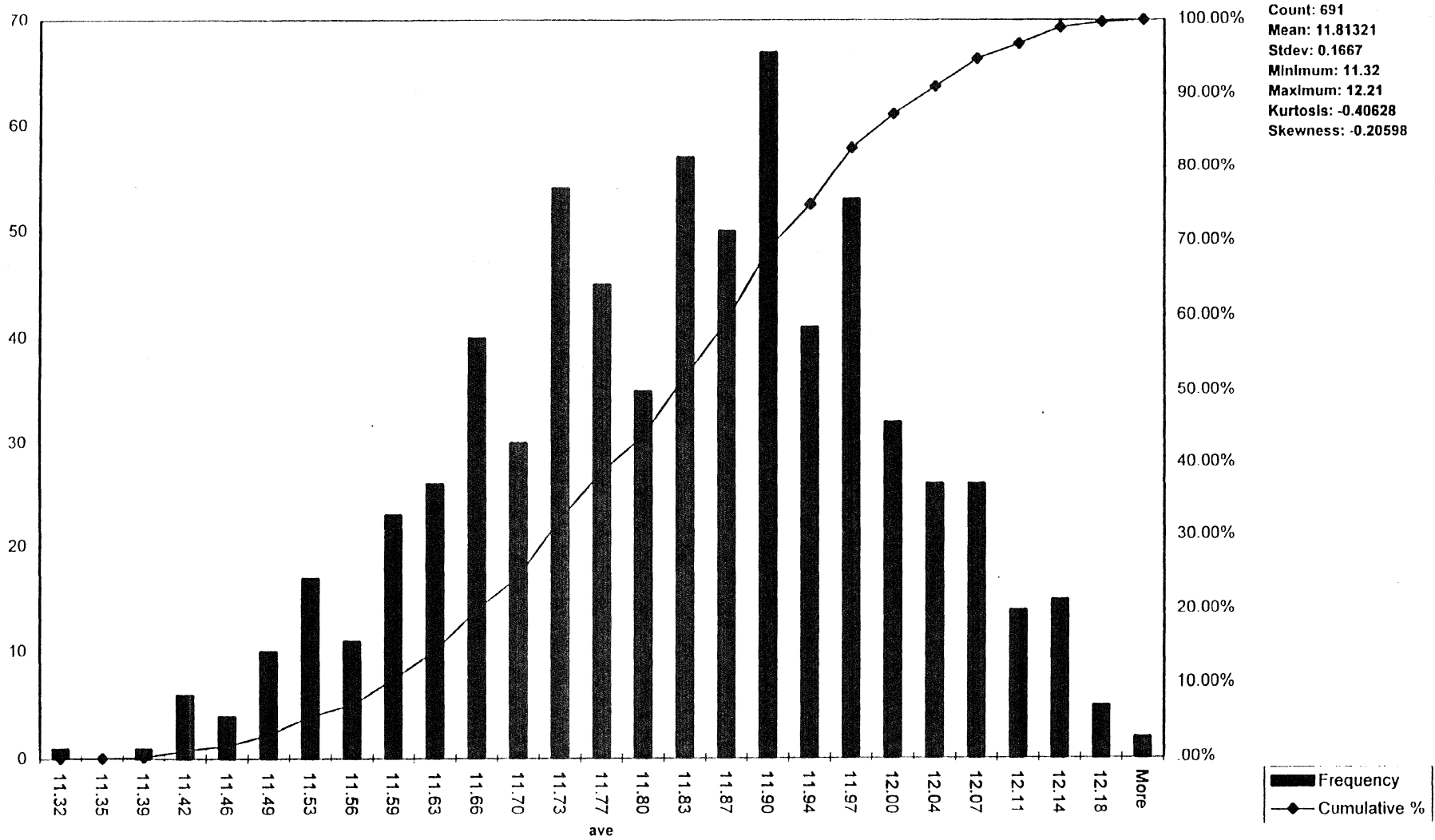



SAGUARO

# Saguaro Settling Criteria

*SG 1.0/2.1*

## ◆ Read Settles

- delta Perr (velocity) < 6% trk / sample for 2 samples

Then

- Perr < 10 % track for 1 sample

## ◆ Write Settles

- delta Perr (velocity) < 6% trk / sample for 2 samples

Then

- Perr < 10 % track for 1 sample

&

- delta Perr (velocity) < 5% trk / sample for 4 samples

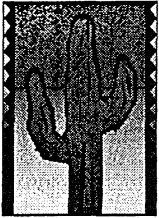

SAGUARO

# Error Detection & Data Protection

*SG 1.0/2.1*

## The SCAIKO ASIC checks for the following errors at each servo wedge:

- ◆ Spindle speed 0.3% away from nominal value
- ◆ Time stamp A/D timed out trying to convert burst values
- ◆ Awedge was flagged as defective at the factory (A & C bursts were erased)
- ◆ Position error signal indicates head is > 10% off track
- ◆ Problem with detection of servo sync field



SAGUARO

# Error Detection & Data Protection

*SG 1.0/2.1*

**The SCAIKO ASIC checks for the following errors at each servo wedge:**

- ◆ Problem with detection of servo address mark (sam)
- ◆ Problem with detection of track number
- ◆ Track number does not match expected track number



# Error Detection & Data Protection

*SG 1.0/2.1*

## **Writing is disabled if:**

- ◆ Errors 1, 2, 3, or 4 are detected in a single wedge
- ◆ Any of the 8 errors are detected in 2 consecutive wedges

**If writing is disabled at a wedge, the data in the sectors between that wedge & the previous wedge is rewritten.**

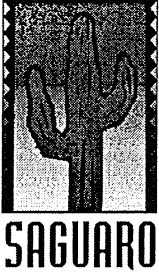

# Drive Power on Calibration

*SG 1.0/2.1*

- ◆ Sapporo power up calibration
  - Obtain electrical offset in servo read channel & optimize the time stamp A/D resolution.
- ◆ Fine PES gain calibration
  - To calculate the gain between the PES (Position Error Signal) amplitude & % offtrack for each head
- ◆ Nulli calibration (adaptive when tracking)
  - Update tracking VCM bias current across the stroke



# Drive Power on Calibration, Cont

*SG 1.0/2.1*

- ◆ Vscale calibration (adaptive during seeks)
  - Adapt servo to VCM difference due to drives variations & temperature
- ◆ Kloop calibration
  - Obtain the difference in  $K_t$  across the stroke
- ◆ Repeatable Runout calibration (adaptive when tracking)
  - Adapt the actuator to follow once around spindle runout





# Drive Power Up Sequence

SG 1.0/2.1

## Operation

## Time

- ◆ Hardware Reset
  - ◆ Setup processor & initialize servo parameters
  - ◆ Spin up & check buffer RAM
  - ◆ Seek to system cylinder & load diskware
  - ◆ Sapporo calibration & fine PES gain calibration
- Total time above 4.16s
- 552 ms



# Drive Power Up Sequence, Cont

SG 1.0/2.1

<u>Operation</u>	<u>Time</u>
◆ Nulli calibration	1.05 sec
◆ Vscale calibration	500 ms
◆ Repeatable runout calibration	186 ms
◆ Kloop calibration	4.63 sec



SAGUARO

# Servo Wedge Format

---

*SG 1.0/2.1*

See Saguaro Training  
Manual for drawing

# SAGUARO SERVO WEDGE FORMAT

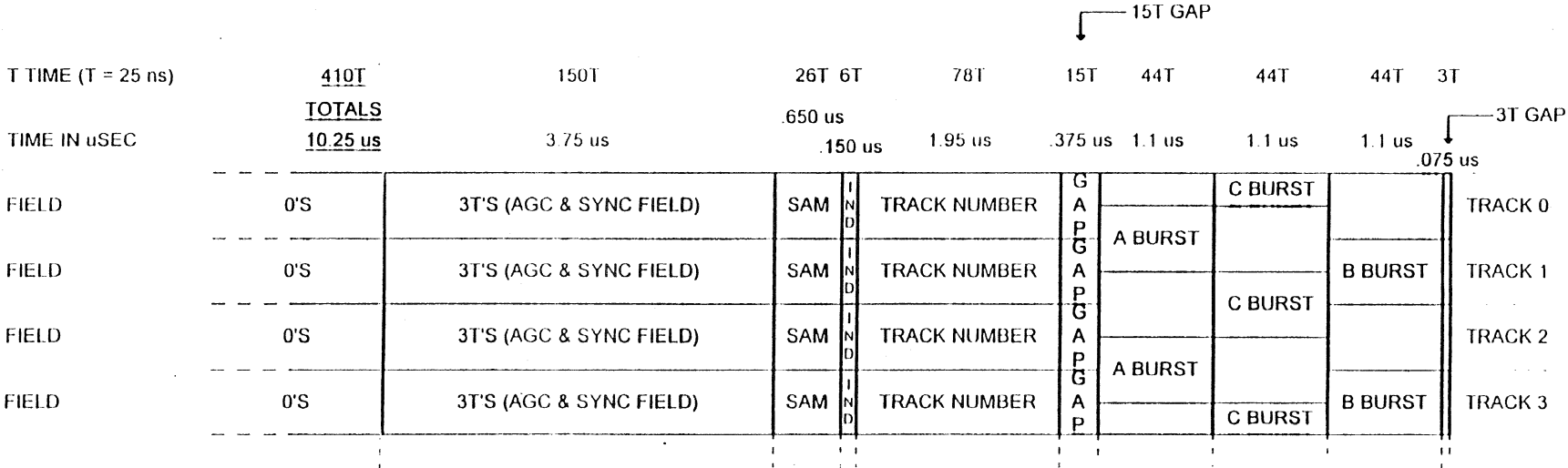

Notes:

- 3T pattern = 100. Fields filled with 3T's contain 100100100... etc.
- Track number is gray coded. Binary to gray code conversion is  $G_{msb} = B_{msb}$ , and  $G_n = B_n \oplus B_{n+1}$ . Example: Binary track number 00Ah = Gray code track number 00Fh. Track number is 13 bits long. Gray code bits are encoded as:
  - Data bit "0" = 000 010 on disk,
  - Data bit "1" = 010 000 on disk.
- SAM = Servo Address Mark = 9T pattern repeated 2 times followed by a 6T and a 2T: 100000000 100000000 100000 10
- IND = Index = data bit "1" (010 000) for wedge 0, and data bit "0" (000 010) for wedges 1 through 79.
- Gap = DC erase = 0's.
- Each burst field contains three 2T's followed by eleven 3T's and five 0's.

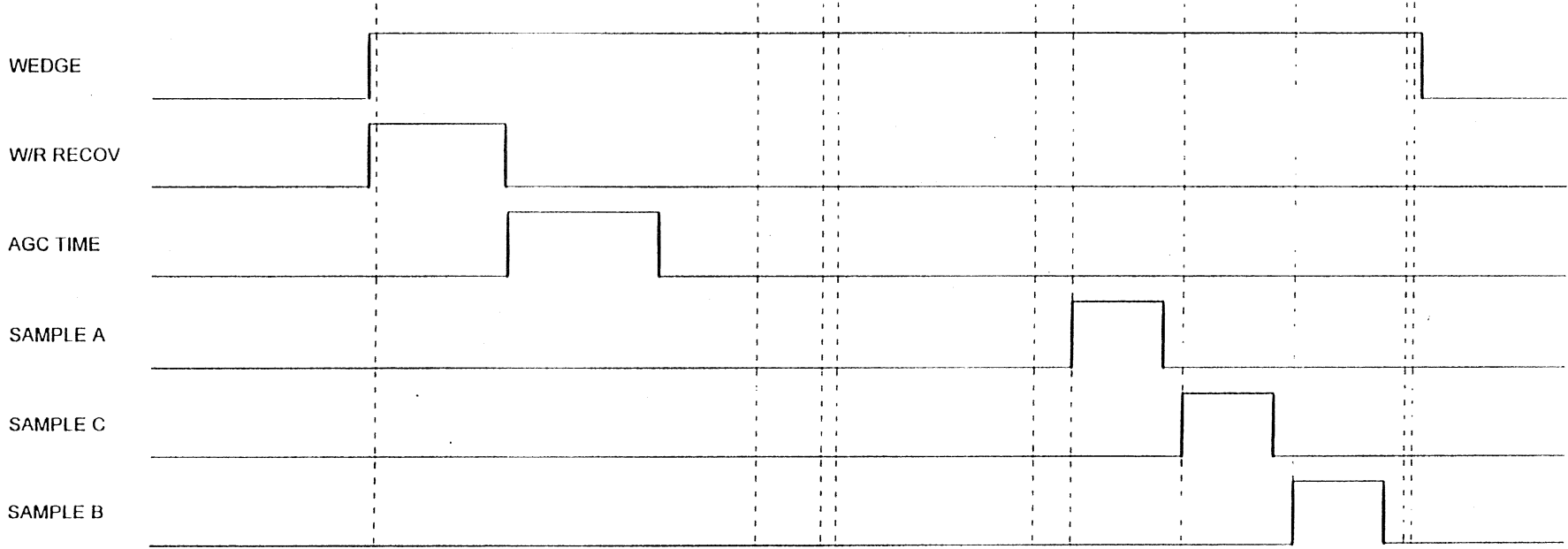



SAGUARO

# Timestamp A/D Conversion

From servo burst demodulator

SG 1.0/2.1

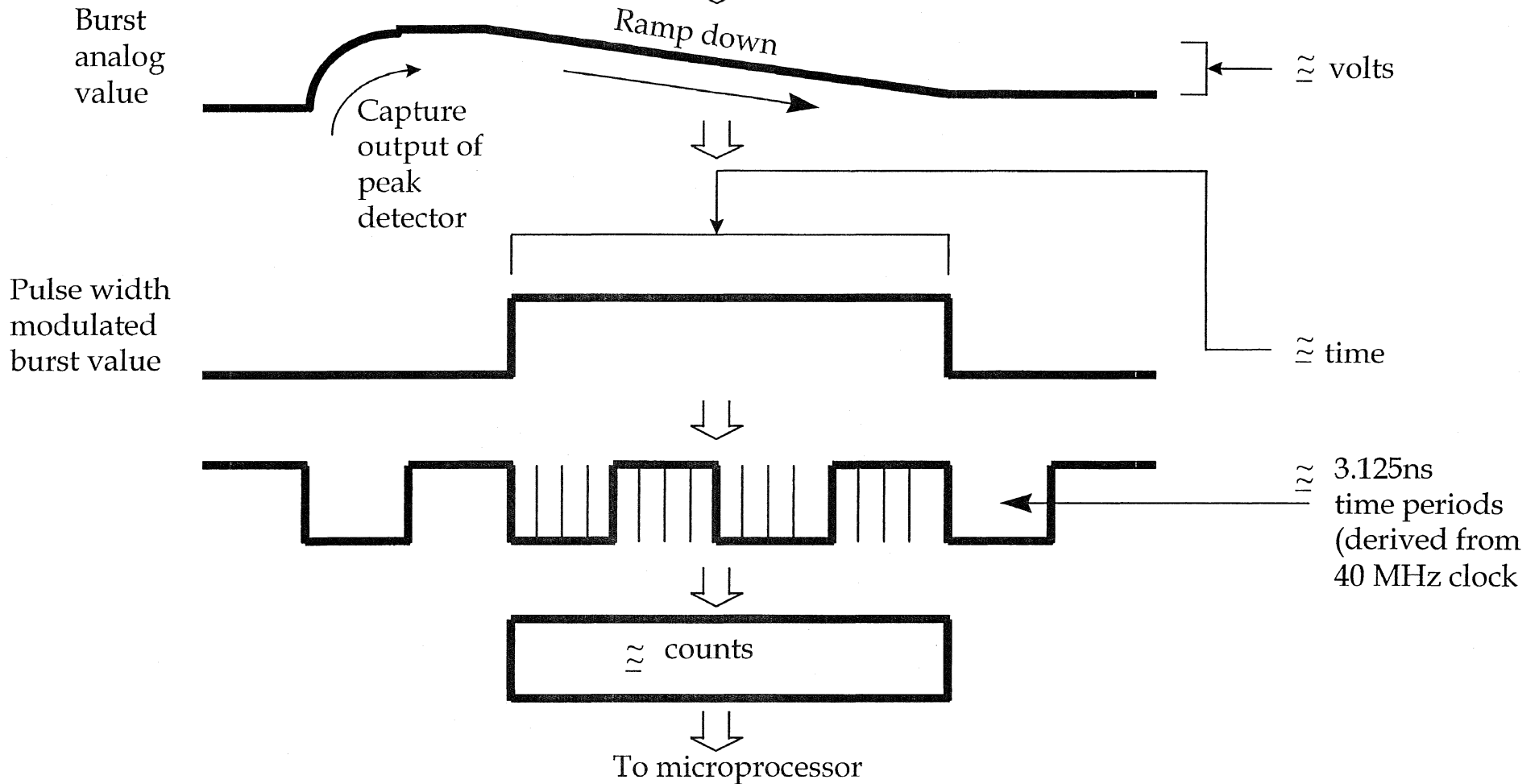



# Servo - Mechanical System

SG 1.0/2.1

## Hardware Block Diagram

See Saguaro Training  
Manual for graph

# Saguaro Servo-Mechanical System: Hardware Block Diagram

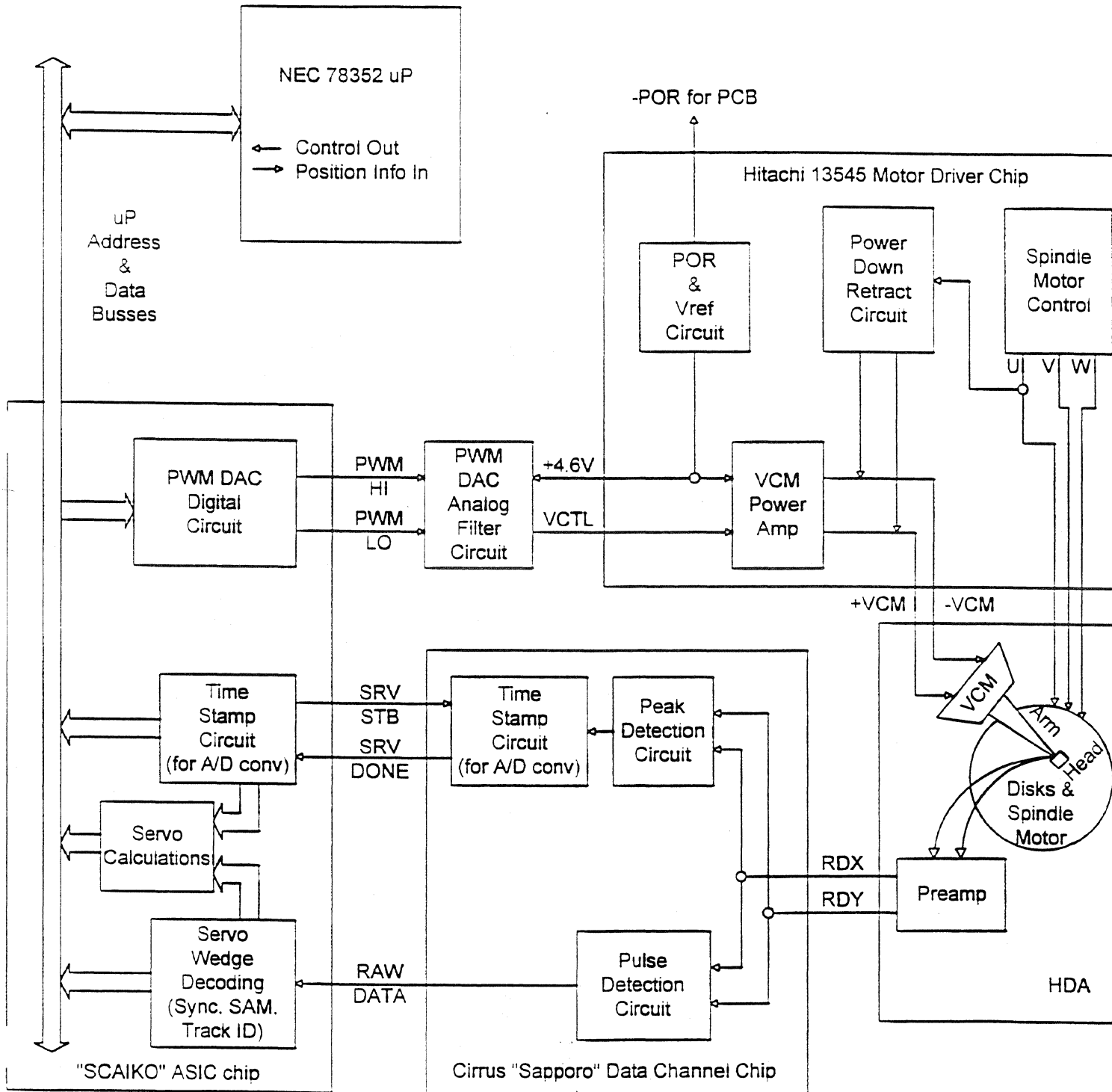

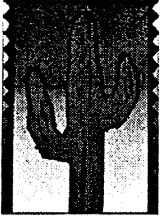

SAGUARO

*Saguaro* DVT / DMT October 1996



*SG 1.0/2.1*



**SAGUARO**





SAGUARO

*SG 1.0/2.1*

**No slides available at time of  
printing  
See attached handout**

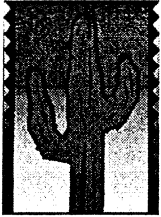

SAGUARO

# *Saguaro* TEST PROCESS Oct 1996



# SAGUARO

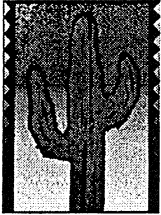

**SAGUARO**

---

# **AN OVERVIEW OF THE SAGUARO TEST PROCESS**

**by PHILLIP NGUYEN**



# TEST PROCESS

---

- ◆ Objectives
- ◆ MKE Test Process Flow
- ◆ Role of UPT2
- ◆ Role of Self Scan
- ◆ Self Scan Script / Parameter File
- ◆ Self Scan TEST.OUT Files
- ◆ Exit codes / error codes
- ◆ List of References



# Objectives

---

- ◆ Coverage of the process elements
  - **UPT2 related MKE test process**
  - **Self scan script and test parameters**
  - **Test exit codes (Error Codes)**
  - **Test.out (not requested by CSG)**



SAGUARO

# MKE TEST PROCESS FLOW

PCB function test -----> Drive Assembly <----- Servo Writer

v

**Diskware Download**

v

**Self Scan Test**

v

**Final Test**

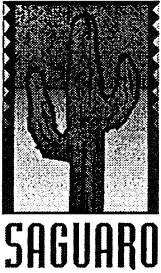

# MKE TEST PROCESS FLOW, Cont

- ◆ MKE follows the test process as depicted, but the end result is accomplished based on two different strategies.
  - **The Manual one does diskware download, self-scan test (HX chamber at 50C)**
  - **Final test at a separate station.**
- ◆ Whereas the Do-All one does all of that in the HX chamber at 50C.

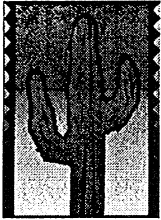

SAGUARO

# MKE TEST PROCESS FLOW, Cont

- ◆ MKE would like to implement Ambient Self Scan Test Process for mass production of Saguaro.
  - **This new process is under evaluation by MKE and Milpitas.**
  - **The new process will allow self scan to be run on all drives on the carts at ambient temperature.**





# Servo Write Station

**Write servo wedges on each available surface.**

**The test sequences are:**

- ◆ Load HDA
- ◆ Barcode
- ◆ Initialize
- ◆ Load clock head
- ◆ Spin up
- ◆ Find crash stop
- ◆ Measure stroke
- ◆ Parametric measurements
- ◆ Write clock track
- ◆ Sam to Sam check
- ◆ Write 3x sample wedges at OD
- ◆ Write servo wedges
- ◆ Write 3x sample wedges at ID
- ◆ Write HDA s/n, S/W id, date and time on id tracks
- ◆ Verify servo wedges
- ◆ Generate test.out
- ◆ Spin down
- ◆ Unload clock head
- ◆ Unload HDA



SAGUARO

# PCB Function Test Station

**Verify the main functions of the PCB.**

**The test sequences are:**

- ◆ Power up; check time to come ready
- ◆ ECC test
- ◆ ECC hardware in the ASIC chip
- ◆ Read/Write test
- ◆ RAM test
- ◆ Seek test
- ◆ Jumper test
- ◆ DMA test

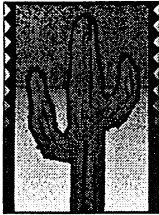

# Diskware Download Station

SAGUARO

**Load firmware (diskware) and drive configuration data on system cylinders. It also write self scan script and password on system cylinder. The drive will execute self scan test the next time it is powered up.**

**The test sequences are:**

- ◆ Power up
- ◆ Detect drive present
- ◆ Write buffer (load config pages 10 & 17)
- ◆ Read serial number/servo information
- ◆ Check if drive history exists
- ◆ Format negative cylinders
- ◆ Power cycles
- ◆ Load ramware
- ◆ Spin up
- ◆ Wedge verify on system cylinders
- ◆ Write drive format
- ◆ Initialize defect list
- ◆ Download diskware
- ◆ Power cycles
- ◆ Write configuration pages
- ◆ Load self scan script



# Self Scan Station

**Test the servo system, train the read channel and map out defects in the media. The test sequences are:**

- ◆ RAM test
- ◆ Set no-find-mode bit
- ◆ Low pass filter compensation
- ◆ Start stop
- ◆ Servo verify
- ◆ Popcorn test
- ◆ Nulli
- ◆ Runout
- ◆ TMR test
- ◆ Fixed seek length
- ◆ Random seek
- ◆ Train read channel
- ◆ Format media
- ◆ Clear no-find-mode bit
- ◆ Head switch and single track seek
- ◆ Physical sequential scan
- ◆ Reassign defects
- ◆ Logical sequential scan
- ◆ Logical random scan
- ◆ Runout
- ◆ Head switch and single track seek
- ◆ Start stop
- ◆ Delete password



# Final Test Station

**Read the results of the self scan test and determine if the drive has passed.**

**The test sequences are:**

- ◆ Power up the drive
- ◆ Servowriter report
- ◆ Self scan report
- ◆ ECC test
- ◆ Start stop
- ◆ Short logical sequential test
- ◆ Write generic configuration

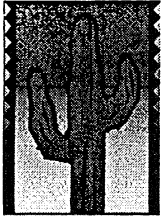

SAGUARO

# THE ROLE OF UPT2

## WHAT IS UPT2 ?

- ◆ Uniform process test
- ◆ Development and production Tool
- ◆ DOS based application written in C++ language
- ◆ Shares low level I/O with DIAG
- ◆ Uniform input and output (database usage)
- ◆ Common core:
  - Parser, parameter handling, test execution, etc.
  - AT/SCSI interface
  - Drive library (error handling, etc.)
  - Tests: Defect scan, seek tests, etc.
- ◆ Drive specific tests added
- ◆ Parameter / script files for flexibility



SAGUARO

# THE ROLE OF UPT2, Cont

## WHAT SERVICES DOES IT PROVIDE TO MAKE TEST PROCESS ?

- ◆ Load diskware
- ◆ Load self scan script and password
- ◆ Read self scan results
- ◆ Perform final test (interface testing)



SAGUARO

# THE ROLE OF SELF SCAN

## WHAT IS SELF SCAN AND WHAT SERVICES DOES IT PROVIDE ?

- ◆ Program code written in assembly language which resides in drive firmware (diskware)
- ◆ Contains a combination of tests
- ◆ Drive Functionality Tests
  - Servo Tests
  - Defect Scan
  - Error Rate
- ◆ Use in MKE mass-production test process
- ◆ Run without a host computer
  - Need host computer to download self scan code and script
  - Need host computer to upload self scan results from drive



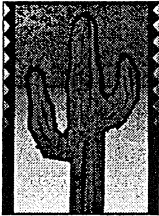

SAGUARO

# SELF SCAN SCRIPT / PARAMETER FILE

## THE STRUCTURE OF SELF SCAN / PARAMETER FILE

- ◆ Header
- ◆ Defect scan pattern list
- ◆ Command definition
- ◆ Command execution



**SAGUARO**

# Self Scan Script / Parameter File

---

See Saguaro Training Manual for this file.

## SAGUARO SELF SCAN SCRIPT / PARAMETER FILE

```

#ifdef ONE_DISK
FILENAME TRB1DSS.SSO
#endif

#ifdef TWO_DISK
FILENAME TRB2DSS.SSO
#endif

ORG 0
WORD(4) 0 ; check sum and 3 blank words
BYTE(8) "SELFSCAN" ; PASSWORD!
BYTE(8) "001.000" ; Script version #
BYTE(8) "SAGUARO" ; Firmware version # - placeholder only, should be set in FW before saving
WORD(7) 0 ; process reserved
WORD 120 ; delay to start time in seconds

The following 16 bytes => Restart control
ORG 0x30
BYTE(6) 0 ; Place holder for output status message.
BYTE 2 ; Restart counts allowed.
BYTE 0 ; Total test count.
BYTE "S" ; Control byte - Start selfscan
BYTE 1 ; Re-"run" count.
BYTE 0 ; test count field, for this "re-run".
BYTE(2) 0 ; Unused in restart control section
BYTE 0 ; Place holder for "last command".
BYTE(2) 0 ; SSR-start-time init/placeholder for results file.

Project specific bytes
ORG 0x40
BYTE 0i00000011 ; Test mode byte -
ORG 0x43 ; start of HERR bytes moved here temporarily (until set globals command coded)
WORD 500 ; Maximum # of hard errors for each HEAD
WORD 6 ; Maximum # of hard errors for each TRACK
WORD 300 ; Maximum # of seek errors for this DRIVE
WORD 25200 ; Maximum selfscan test time in seconds

#ifdef ONE_DISK ; overwrite data if specific config is set in compile options
ORG 0x14
BYTE(4) "S1D" ; Script version #
ORG 0x47 ; start of HERR bytes moved here temporarily (until set globals command coded)
WORD 300 ; Maximum # of seek errors for this drive
WORD 11000 ; Maximum selfscan test time in seconds
#endif

#ifdef TWO_DISK
ORG 0x14
BYTE(4) "S2D" ; Script version #
ORG 0x47 ; start of HERR bytes moved here temporarily (until set globals command coded)
WORD 600 ; Maximum # of seek errors for this drive
WORD 18000 ; Maximum selfscan test time in seconds
#endif

ORG 0x4B
BYTE 0 ; Format track PATTERN ('0').
BYTE 3 ; Format track retries.
BYTE 1 ; Verify track pattern INDEX (pattern 'ee').

WORD 10 ; Tot # hard errs/trk to disallow max cyls w/max hards.
WORD 100 ; Cyl spacing between cyls above
WORD 10 ; Min cyl number to allow max hard defects / (servo defects).
BYTE 0xFF ; SAPPORO_R24, bits [1:0], 0xff is "use default"

BYTE(43) 0 ; Unused in project specifics section

; Now let us do test result sectors list.
ORG 0x80

BYTE 00 ; ID 0 for RESULT
BYTE 39 ; Starting sector.
BYTE 8 ; Number of blocks
BYTE 0 ; Reserved

BYTE 02 ; Defect list, File 0
BYTE 61 ;
BYTE 8 ;
BYTE 0 ;

BYTE 02 ; Defect list, File 1
BYTE 69 ;
BYTE 8 ;
BYTE 0 ;

BYTE 02 ; Defect list, File 2
BYTE 77 ;
BYTE 8 ;
BYTE 0 ;

BYTE 02 ; Defect list, File 3
BYTE 85 ;

```

```

BYTE 8 ;
BYTE 0 ;

BYTE 02 ; Defect list, File 4
BYTE 93 ;
BYTE 8 ;
BYTE 0 ;

BYTE 02 ; Defect list, File 5
BYTE 101 ;
BYTE 8 ;
BYTE 0 ;

BYTE 02 ; Defect list, File 6
BYTE 109 ;
BYTE 8 ;
BYTE 0 ;

BYTE 02 ; Defect list, File 7
BYTE 117 ;
BYTE 8 ;
BYTE 0 ;

BYTE 03 ; Servo Wedge Defect map
BYTE 49 ;
BYTE 8 ;
BYTE 0 ;

BYTE 04 ; Runout results
BYTE 57 ;
BYTE 4 ;
BYTE 0 ;

BYTE 06 ; Adaptive results.
BYTE 125 ;
BYTE 8 ;
BYTE 0 ;

BYTE 0A ; Nulli results.
BYTE 48 ;
BYTE 1 ;
BYTE 0 ;

```

```

*****
DEFECT SCAN PATTERN LIST
*****

```

```

DRG 0xCO ; Defect Scan Patterns - (up to 20 16 byte patterns total)
; Each pattern record starts with a length byte, so that each
; record is 17 bytes long. The pattern starts in the next byte
; and the record is zero filled.

PATTERN16 ee ; 1 - 2T
PATTERN16 bb ; 2 - 2T
PATTERN16 5a ; 3 -
PATTERN16 a5 ; 4 -
PATTERN16 68 ; 5 -
PATTERN16 ff ; 6 -
PATTERN16 rand 10 ; 7 - random
PATTERN16 0 ; 8 - data pattern '0'.

PATTERN16 2f be f8 e2 8b ; 9 - 2T3T
PATTERN16 rand 0 ; 10 - random
PATTERN16 88 ; 11 - 4T2T
PATTERN16 9b d4 26 b5 49 6d 52 ; 12 - 2T5T
PATTERN16 2d 59 ; 13 - 2T6T
PATTERN16 d7 75 5d ; 14 - 7T2T
PATTERN16 76 ; 15 - for adaptive
PATTERN16 FE BF BF FD ; 16 - Aprox2tPattern for adaptive
PATTERN16 6E CF CF DB DB 73 F6 CF ; 17 - TriBitPattern for adaptive

```

```

*****
COMMAND DEFINITION SECTION |
*****

```

```

NOTE: this section is used to define input parameter NAMES, TYPES, and
DEFAULT DATA VALUES. Each command parameter is initialized with the value
set here and is only changed if explicitly defined in the execution section.
*****

```

```

legDefectScan 1
CmdFlag BYTE 00H ; Sequential sector defect scan
; bit 7 - If SET, do NOT use h/w ecc.
LoopCount BYTE 1 ; Overall defect scan loop count
ReadLoops BYTE 2 ; Read loop count per pattern
WriteLoops BYTE 1 ; Write loop count per pattern
ReadRetries BYTE 4 ; Medium error read retries
WriteRetries BYTE 4 ; Medium error write retries
SoftErrorsPerHead WORD 2000 ; Maximum # of soft errors per head
SoftErrorsPerDrive WORD 20 ; Maximum # of soft errors per 10 MB
DataPatterns BYTE[8] 7 6 8 0 ; Data pattern list
AmTol BYTE 0 ; Address Mark tolerance: 0 = "default"; 1 = stress.
ViterbiLevel BYTE 0ffh ; Viterbi "threshold": 0ffh = "use default" (16=default, 32=Max.)
StartingCylinder WORD 0 ; Starting cylinder #
EndingCylinder WORD 0FFFF ; Ending cylinder #
OfftrackScan BYTE[3] 00H 00H 0 ; Offtrack value (in microsteps) during scanning

```

```

:IndexTimeout      BYTE    2      ; New value of index timeout, 0xff is use default.
:
DeletePassword     2
:CmdFlag           BYTE    0      ;
:
LowLevelFormat     4
:CmdFlag           BYTE    0      ; Bit 1 Set == use format_2 sequencer cmdnd.
:FormatRetries     BYTE    10     ; Maximum # of format track retries to execute after a format track error
:StartingCylinder  WORD    0      ; Starting cylinder #
:EndingCylinder    WORD    0FFFF  ; Ending cylinder #
:DataPattern       BYTE    0      ; Default is data '0'
:

```

Bit definitions used in ServoVerify "Servo Flags Mask" parameter

```

0 - LST_TRK_MISCOMPARE - Track miscompare error
1 - LST_TRKNUM_OR_INDEX_ERR - Track # or Index error
2 - LST_SAM_ERR - Servo AM bad
3 - LST_SYNC_ERR - Sync error
4 - LST_BUMP_ERR - Bump error
5 - LST_ERASED_AC_BURST - Erased AC Burst
6 - LST_TS_TIMEOUT_ERR - TS timeout error
7 - LST_SPEED_ERR - Motor speed out of range

```

```

-----
ServoVerify        5
:CmdFlag           BYTE    3      ; Servo verify
; bit 0 == FATAL ERROR if set
; bit 1 == Cylinder Sparing Enabled if set
:StartingCylinder  WORD    0      ; Cylinder # with which to start scanning
:EndingCylinder    WORD    0FFFF  ; Cylinder # with which to end scanning
:RevsPerTrack      BYTE    2      ; # of times to scan each track
:ServoErrorRetries BYTE    7      ; # of retries to execute when a servo error is found
:DefectThreshold   BYTE    4      ; See a servo error 3 time - soft error; see it 4 times - hard error.
:BumpLimit         WORD    41     ; Bump limit to use when scanning
:ServoErrorMask    BYTE    0i00111111 ; Mask to apply to the servo error flags in order to determine a servo error (?)
:MaxHardErrsPerTrk BYTE    2      ; Max # of HARD errors per TRACK.
:MaxErrorsPerTrack BYTE    2      ; Max # of C-Burst errors per TRACK.
:EraseCBurstFlag   BYTE    1      ; If set to 1, C-bursts of selected bad wedges will be erased.
:ServoDefectMask   BYTE    0i00110000 ; Mask to apply to the servo error flags in order to determine a servo defect
:MaxErrorsPerHead  BYTE    50     ; Max # of HARD errors per HEAD (per surface).
:NumCBurstsErase   BYTE    2      ; # of C-bursts to erase per TRACK.
:CBstEraseSeparation BYTE    6     ; Min # of wedges between C-bursts to erase.
:MinZeroDfctTrksOd WORD    3      ; Min # trks at OD to be defect free (0-2).
:

```

```

-----
HeadSwitch         8
:CmdFlag           BYTE    0      ; Bit 1 Set = Read on arrival on
:LoopCount         BYTE    1      ; Number of sequential loops
:HeadSwitchLimit   WORD    4500   ; Max limit for head switch only in microseconds
:TrackSwitchLimit  WORD    5000   ; Max limit for head and track switch in microseconds
:

```

```

-----
FixedLengthSeek    016
:CmdFlag           BYTE    0x0A   ; Bit 1 Set = Read on arrival on;
; Bit 2 Set = seek forever;
; Bit 3 Set = info only (DON'T fail drive)
:LoopCount         WORD    0      ; # of full stroke seeks to execute
:SeekTimeLimit     WORD    29000  ; Maximum average full stroke seek time in microseconds
:Steps             WORD    0      ; step increments
:

```

```

-----
SeekAwhile         0B
:CmdFlag           BYTE    0x08   ; Read on arrival off, info only
; Bit 1 Set = Read on arrival on
; Bit 2 Set = seek forever
; Bit 3 Set = info only (dont fail drive)
:SweepTime         WORD    0      ; time to sweep in minutes
:StartCyl          WORD    0      ; sweep start cylinder
:EndCyl            WORD    0      ; sweep end cylinder
:Steps             WORD    0      ; cylinder step increments
:

```

```

-----
RandomSeek         0A
:CmdFlag           BYTE    2      ; Bit 1 Set = Read on arrival on
; Bit 2 Set = seek forever;
; # of seek sets to execute
:LoopCount         WORD    1
:SeekTimeLimit     WORD    13000  ; Maximum average random seek time in microseconds
:NumberOfSeeks     WORD    20000  ; # of seeks to execute per set
:

```

```

-----
StartStop         0C
:CmdFlag           BYTE    1      ; Bit 0 set - enables ss-f0-fatal-error.
:LoopCount         WORD    5      ; Overall loop count
:LoopDynBrk        BYTE    1      ; # of loops to stop WITH Dynamic Brake
:LoopNoDynBrk      BYTE    0      ; # of loops to stop with NO Dynamic Brake
:StopDelay         BYTE    4      ; Delay in seconds after drive stops
:

```

```

:StartDelay      BYTE 1 ; Delay in seconds after drive starts
:NoDynBrkDelay  BYTE 23 ; Delay in SECONDS to wait before turn off vcm w/no dynamic brake.
:StartTimeLimit BYTE 150 ; Start time limit in TENTHS of seconds
:MaxStartLimit  BYTE 0 ; Max # of times allowed to exceed start time limit
:MaxStartFail   BYTE 0 ; Max # of consecutive times start can fail - then force fatal
:               ; Only applies when ss-f0-fatal-error is disabled

```

```

-----
Runout          0F
:CmdFlag        BYTE 1 ; Bit 0 set - enables ss-f0-fatal-error.
:RROLimit       WORD 65 ; Maximum RRO (1 tenth of a percentage of a track)
:NRROLimit      WORD 65 ; Maximum NRRO (1 tenth of a percentage of a track)
:TotalLimit     WORD 80 ; Maximum RRO/NRRO limit: SQRT(rro*rro + nrro*nrro)
:Cylinder       WORD[8] 0 1332 2665 3997 5330 0ffffh ; Cylinders on which to measure runout
:NumberOfRevs   BYTE 127 ; # of revs of data to take per measurement

```

```

-----
BraseCBursts    015 ; Specify CHS. For (debug) only.
:CmdFlag        BYTE 0 ;
:Cylinder       WORD 0 ;
:Head          BYTE 0 ;
:Sector        BYTE 0 ;

```

```

-----
RamTest         019 ; Buffer ram test
:CmdFlag        BYTE 0 ;
:LoopCount      BYTE 1 ; Overall loop count

```

```

-----
LogicalSequential 020
:CmdFlag        BYTE 0i10010000 ; bit 1 - If set, don't include "SOFT" errors in SS defect list.
; bit 2 - Read-on-arrival ON if set, else off.
; bit 3 - If set, will NOT compute error rates
; bit 4 - If set, clear all previous transfer block counts and errors
; bit 5 - If set, don't do free wiggle fix before all retries
; bit 6 - If set, do not include "recovered" errors in SS defect list.
; bit 7 - If set, ignore 8-bit-span correctable ecc-errs.
:LoopCount      BYTE 1 ; Overall loop count
:RdLoopCount    BYTE 1 ; Read loop count
:WrLoopCount    BYTE 1 ; Write loop count
:StartLba       TRIBYTE 0 ; Starting LBA
:EndLba         TRIBYTE 0xFFFFF ; Ending LBA
:SeqBlkPerXfer  WORD 255 ; Sequential blocks per transfer
:PatternIndex   BYTE[8] 8 0 ; Data pattern index
:ReadRetries    BYTE 4 ; Read retries on error
:WriteVerifyRetries BYTE 4 ; write and read verify retries on error
:RawErrors      WORD 10000 ; raw errors allowed in 10^10 bits
:SoftErrors     WORD 10 ; Soft errors allowed in 10^10 bits
:HardErrors     WORD 2 ; Hard errors allowed in 10^10 bits
:NonRecoveredErrors BYTE 0 ; non-recovered errors allowed
:MaxReadBumps   WORD 0xFFFF ; 0xFFFFH == flag for NO LIMIT
:MaxWriteBumps  WORD 200 ; maximum write bumps
:BumpLimit      WORD 0xFF ; Bump limit to use when scanning (ff default)
:ECC_corr_hard  BYTE 5 ; if (ReadRetries+1) ECC correctables, THEN hard.

```

```

-----
LogicalRandom     021
:CmdFlag        BYTE 0i10000000 ; bit 1 - If set, don't include "SOFT" errors in SS defect list.
; bit 2 - Read-on-arrival ON if set, else off.
; bit 3 - If set, will NOT compute error rates
; bit 4 - If set, clear all previous transfer block counts and errors
; bit 5 - If set, don't do free wiggle fix before all retries
; bit 6 - If set, do not include "recovered" errors in SS defect list.
; bit 7 - If set, ignore 8-bit-span correctable ecc-errs.
:LoopCount      BYTE 1 ; Overall loop count
:RdLoopCount    BYTE 0 ; (sequential) Read loop count
:WrLoopCount    BYTE 0 ; (sequential) Write loop count
:StartLba       TRIBYTE 0 ; Starting LBA
:EndLba         TRIBYTE 0xFFFFF ; Ending LBA
:SeqBlkPerXfer  WORD 255 ; Sequential blocks per transfer
:PatternIndex   BYTE[8] 8 0 ; Data pattern index
:ReadRetries    BYTE 4 ; Read retries on error
:WriteVerifyRetries BYTE 4 ; HARD error threshold
:RawErrors      WORD 10000 ; raw errors allowed in 10^10 bits
:SoftErrors     WORD 10 ; Soft errors allowed in 10^10 bits
:HardErrors     WORD 2 ; Hard errors allowed in 10^10 bits
:NonRecoveredErrors BYTE 0 ; non-recovered errors allowed
:MaxReadBumps   WORD 0xFFFF ; 0xFFFFH == flag for NO LIMIT
:MaxWriteBumps  WORD 200 ; maximum write bumps
:BumpLimit      WORD 0xFF ; Bump limit to use when scanning (ff default)
:ECC_corr_hard  BYTE 5 ; if (read-retries+1) ECC correctables, THEN hard.
:RandNumBlocks  LONG 0x6FC23B ; * 1(patterns) * 512 * 8 = 3e10 bits xfer.
:MaxRandBlksPerXfer WORD 255 ; Max number of blocks per xfer for random
:RandomSeedLo   WORD 0x1234 ; Random seed (Low Word)
:RandomSeedHi   WORD 0x5678 ; Random seed (High Word)
:RandComSequence BYTE[8] 1 1 1 1 2 0 ; Random command sequence (read or write sequence)

```

```

-----
OfftrackRead     022
:CmdFlag        BYTE 0i00001010 ; bit 1 - output in microsteps in percentage

```

```

; bit 2 - do not format test track and its adjacent tracks
; bit 3 - do not count errors correctable with 8-bit ecc-on-the-fly
:OfftrackTestCyl      WORD      100    ; test cylinder
:SkipCylinder         BYTE      0FB    ; skip cylinder
:VerifyTrackRetries   BYTE      5      ; number of retries for verify good tracks
:TransferBlocks       WORD      2442   ; number of blocks to transfer
:MicrostepIncrement   BYTE      3      ; step per increment
:PercentOfftrackWrite BYTE      0      ; write adjacent tracks with PERCENT offtrack
:ReadErrorsTolerance BYTE      10     ; read error threshold
:TestTrackPattern     BYTE      7      ; test track pattern for offtrack read
:AdjacentTrackPattern BYTE      10     ; adjacent track test pattern
:PercentToStop        BYTE      7      ; percent microsteps to stop
:PercentToStart       BYTE      20     ; percent microsteps to start
:PercentMinOfftrack   BYTE      12     ; required minimum percent microsteps
:BadZonesPerHead     BYTE      0      ; number of bad zones per head allowed
:MeasurementRetries   BYTE      1      ; retries allowed in offtrack measurement
:

```

```

-----
ReassignPhysical      026
:CmdFlag              BYTE      0      ;
:

```

```

-----
LPFComp              032
:CmdFlag              BYTE      0110000000 ; bit 7 - Update config page bit
:

```

```

-----
TestBitMap mapping. The following bit assignments correspond to adaptive
sub-test or CPI7 parameters to be adapted. Test may be enabled or disabled.
Note: Test are not executed in this order.

```

```

0 - IW                ;WriteCurrent (PWM)
1 - ZPR               ;ZPR(10h)
2 - VGA               ;VGAatst(2Bh) and DC Offset(29h)
3 - WPC               ;Write PreComp(09h)
4 - BW                ;ReadBW(03h)
5 - BST               ;ReadBoost(01h)
6 - PTF               ;Pole-tip filter LC01(26),TL2(27),LTDELAY(28)
7 - NCR               ;No Copy or Repeat of zone zero

```

```

SgrAdaptive          02A
:CmdFlag              BYTE      0110000000 ; bit 7 - Update config page bit
; bit 1 and 0 - 00 = adapt at the ID of a zone
;                01 = adapt at mid zone
;                10 = adapt at the OD of a zone
;                11 = unused
; note that these options apply to all zones except
; the system zone. The system zone location is fixed.
:TestBitMap          BYTE      0101111111 ; Enable or disable sub-test
:Confidence           WORD      541      ; (times 100).
:StartZone           BYTE      0        ; Starting Zone
:EndZone              BYTE      16      ; Ending Zone
:Aprox2tPattern       BYTE      16      ; for ZPR and DC offset
:TriBitPattern        BYTE      17      ;
:ZeroPattern          BYTE      8        ; a pattern of zeros
:TestParams           BYTE      [16] 0   ; input test parameters
:

```

```

-----
ModifyFindMode       02B
:CmdFlag              BYTE      0        ; Bit 1 == Set NO_FIND_MODE bit. (bit 1 clr clears it).
:

```

```

-----
ServoArrivalTMR      02F
:CmdFlag              BYTE      0        ; Bit 0 enables ss-f0-fatal-error.
:CmdTargetCyl        WORD      100
:CmdTargetHd         BYTE      0
:CmdWrBumpLimit      WORD      41      ; 8%
:CmdNumSeeks         WORD      1000
:CmdBumpLimit        WORD      100
:

```

```

-----
PopCorn              030
:CmdFlag              BYTE      0
:Cylinder             WORD      100
:LoopCount           BYTE      100
:SrvoMask            BYTE      0x0C    ; Sync, SAM errors only.
:

```

```

-----
Null1                031
:CmdFlag              BYTE      0
:Cylinders            BYTE      32     ; Number of Cylinders accross stroke.
:RevCount            BYTE      3
:LowLimit            WORD      4000
:HighLimit           WORD      4500
:DeltaLimit          WORD      15     ; between any 2 points in/out data
:IODiffLimit         WORD      30     ; between in/out values per cylinder.
:

```

\*\*\*\*\*

## EXECUTION SECTION

\*\*\*\*\*

```

ORG                0200

RamTest

ModifyFindMode CmdFlag      0x02    ; SET the no-find-mode bit.
ModifyFindMode

LPFComp

StartStop

ServoVerify

PopCorn Cylinder      100
PopCorn

PopCorn Cylinder      2500
PopCorn

PopCorn Cylinder      5000
PopCorn

Nulli

Runout

ServoArrivalTMR

; ; ... Seek Lengths ...

FixedLengthSeek LoopCount      1      ; # of loop counts
FixedLengthSeek Steps          1      ; step increment
FixedLengthSeek LoopCount      1      ; # of loop counts
FixedLengthSeek Steps          2      ; step increment
FixedLengthSeek LoopCount      1      ; # of loop counts
FixedLengthSeek Steps          4      ; step increment
FixedLengthSeek LoopCount      1      ; # of loop counts
FixedLengthSeek Steps          8      ; step increment
FixedLengthSeek LoopCount      1      ; # of loop counts
FixedLengthSeek Steps          16     ; step increment
FixedLengthSeek LoopCount      1      ; # of loop counts
FixedLengthSeek Steps          32     ; step increment
FixedLengthSeek LoopCount      1      ; # of loop counts
FixedLengthSeek Steps          64     ; step increment
FixedLengthSeek LoopCount      2      ; # of loop counts
FixedLengthSeek Steps          128    ; step increment
FixedLengthSeek LoopCount      2      ; # of loop counts
FixedLengthSeek Steps          256    ; step increment
FixedLengthSeek LoopCount      4      ; # of loop counts
FixedLengthSeek Steps          512    ; step increment
FixedLengthSeek LoopCount      8      ; # of loop counts
FixedLengthSeek Steps          1024   ; step increment
FixedLengthSeek LoopCount      16     ; # of loop counts
FixedLengthSeek Steps          2048   ; step increment
FixedLengthSeek

FixedLengthSeek CmdFlag      0x02    ; Read on arrival on, test limit.
FixedLengthSeek LoopCount      500   ; # of loop counts
FixedLengthSeek Steps          5330   ; step increment
FixedLengthSeek

RandomSeek

**** End of Seek Testing

SgrAdaptive

OfftrackRead OfftrackTestCyl      397
.OfftrackRead

LowLevelFormat

ModifyFindMode CmdFlag      0      ; CLEAR the no-find-mode bit.
ModifyFindMode

HeadSwitch

SeqDefectScan

ReassignPhysical

LogicalSequential CmdFlag      0x90   ; Ignore8, Clr counts/errs, rd-on-arrival OFF.

```



LogicalSequential

LogicalRandom CmdFlag 0x80 ; Ignore8, read-on-arrival OFF.  
LogicalRandom

Runout

HeadSwitch

StartStop

DeletePassword

BYTE 0xff

CHKSUM

ORG 4096

\*\*\* END OF FILE \*\*\*



SAGUARO

# SELF SCAN TEST.OUT

## THE STRUCTURE OF THE TEST.OUT FILE

- ◆ Header
  - Message, exit code, return code, etc.
- ◆ Test Summary
  - Test name, self scan error code, firmware error code, etc
- ◆ Data Summary
  - Output data for each test sequence
- ◆ Defect Summary
  - Data defect counts, map and graph
  - Servo defect counts and map
- ◆ Additional output data for some test sequences
  - Runout
  - Train read channel
  - Nulli



SAGUARO

# EXIT CODES / ERROR CODES

- ◆ Self scan saves test results which include data of all test sequences, self- scan error code and firmware error code to designated negative cylinders.
- ◆ UPT2 is used to extract self scan results and saved it in test.out file.
- ◆ The test.out file for failed drive usually consists of four different error codes: UPT2 exit code, UPT2 return error code, self scan error code, and firmware error code. these error codes attempt to explain different level of details related to the failure under discussion.



# EXIT CODES / ERROR CODES, Cont

- ◆ UPT exit code (EC) and return error code (RC) are contained in exitcode.err file.
- ◆ Self scan error code is contained in self scan manual.
- ◆ Firmware error code (or drive error code ) is contained in sag.err file and the Firmware manual.
- ◆ UPT2 exit code
  - **2 digit hex**
  - **Shown on LED after test finishes**
  - **Used for grouping errors (e.g. looking at yield)**



SAGUARO

# EXIT CODES / ERROR CODES, Cont

## UPT2 return error code

- ◆ 4 digit hex
- ◆ UPT2 internal return code for each test
- ◆ Internal is translated into EC.
  - **Many RC to one EC**
- ◆ Bit 7 - 0 (sub lib)
  - **Sub library code**
  - **What error inside library**



# EXIT CODES / ERROR CODES, Cont

## ◆ Bit 12 - 8 (library)

- 0x1e00 ASPI library
- 0x1d00 HSC library
- 0x1c00 AT library
- 0x1b00 BIOS library
- 0x1100 Drive error
- 0x1000 Drive library
- 0x0800 Seek time library
- 0x0500 Self scan library
- 0x0400 Drive self scan library
- 0x0300 Defect library
- 0x0200 Parameter library
- 0x0100 Drive initialization
- Others



# EXIT CODES / ERROR CODES, Cont

---

- ◆ Bit 15 - 13 (special)
  - 0x8000 Fatal error
  - 0x4000 Interface not ready
  - 0x2000 Not used



# LIST OF REFERENCES

---

- ◆ Saguaro self scan manual (Microsoft doc.)
- ◆ Saguaro exitcode.err file (Text file)
- ◆ Saguaro sag.err file (Text file)
- ◆ Saguaro passed and failed test.out files (Text file)



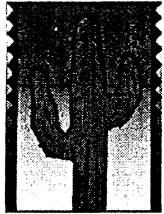

**SAGUARO**

# ***Saguaro* FAILURE ANALYSIS 10/96**



*SG 1.0/2.1*



# **SAGUARO**



**SAGUARO**

*SG 1.0/2.1*

**No slides available at time of  
printing  
See attached handout**