

# MODEL 730-1 PRINTER

## OWNER'S MANUAL

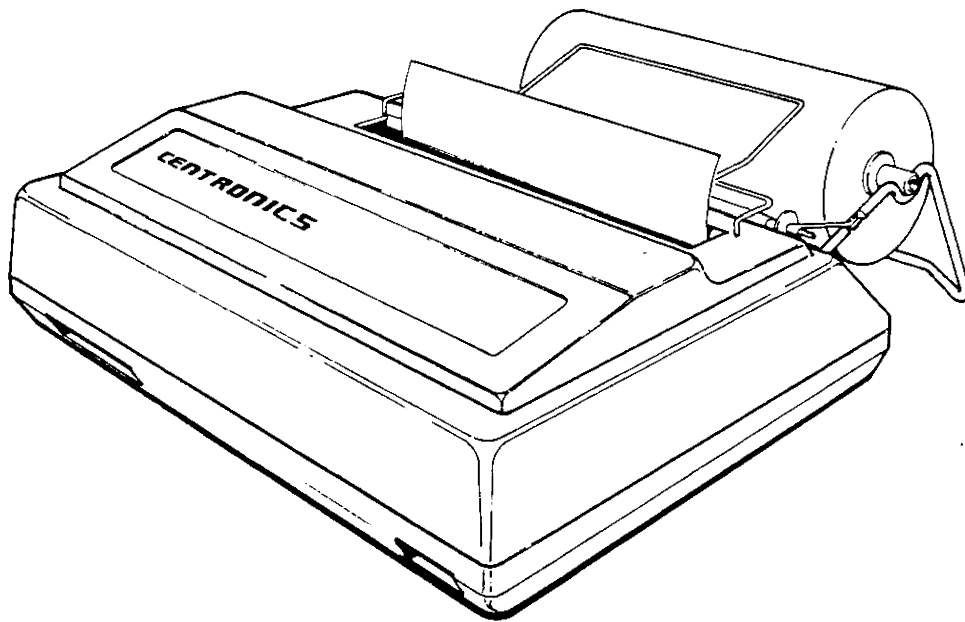

DECEMBER 1979  
Centronics No. 37400741 Rev.-2

**CENTRONICS®**  
data computer corporation  
Hudson, New Hampshire 03051  
Telephone (603) 883-0111

TABLE OF CONTENTS

| <u>SECTION</u>                    | <u>PAGE</u> |
|-----------------------------------|-------------|
| INTRODUCTION . . . . .            | 1           |
| SPECIFICATIONS . . . . .          | 2           |
| SETTING UP . . . . .              | 3           |
| RIBBON INSTALLATION . . . . .     | 8           |
| OPERATION . . . . .               | 10          |
| PRINCIPLES OF OPERATION . . . . . | 12          |
| PRINTER INTERFACE . . . . .       | 17          |
| MAINTENANCE . . . . .             | 21          |

## INTRODUCTION

The Model 730-1 is an operationally simple, compact, microprocessor controlled, dot-matrix, impact printer. The unit prints 7x7 dot matrix characters at 10 characters per inch in line lengths up to 8 inches at a rate of 100 characters per second. The printer features three-way paper handling.

1. 9-1/2" (9" pin to pin) wide standard computer fanfold forms, with fixed position pins to ensure pinfeed paper registration. The paper can be multipart up to three parts.
2. Rolled paper, 3-1/2 to 8-1/2" wide, 1" core and up to 5" diameter. The printer includes a roll paper holder. A built-in rip-and-read cutting edge allows easy removal of paper. The first line of following page is printed within five lines of tear edge. Two ply paper may be used with operator attendance.
3. Single sheets of 8-1/2 inch wide paper, hand fed as with an ordinary typewriter.

The printer's character set consists of 96 US ASCII characters. Normal size characters can be printed at up to 80 characters per line. Elongated characters which are double-width characters can be printed at up to 40 characters per line.

Other significant features include:

1. Reliable free-flight head.
2. Microprocessor technology.
3. Full line buffer.
4. Fast carriage return at 10" per second.
5. Special line feed buffer for host-controlled forms control.
6. Compact size (5"H x 14-1/2"W x 11"D).

## SPECIFICATIONS

|                               |  |
|-------------------------------|--|
| Ribbon (12 per box)           | 20-yard zip pack mobius loop<br>(Centronics Part No. 63701468-6003)  |
| Paper                         | Cut Sheets (8-1/2" wide)<br>Rolls (3-1/2" to 8-1/2" wide x 5" diameter<br>with 1" Core), 2 ply<br>Fanfold (9" pin-to-pin), 3 ply |
| Printing Speed                | 28 lines per minute (lpm) at 80 characters<br>per line (cpl) or 74 lpm at 20 cpl left justified                                  |
| Characters Per Line           | 80 maximum   |
| Print Width                   | 8 inches maximum (204 mm)  |
| Character Structure           | 7x7 Dot Matrix   |
| Line Feed Buffer              | Capacity for 255 pending line feeds.   |
| Line Feed Repeat Rate         | 9 line feeds/second  |
| Vertical Spacing              | 6 lines per inch   |
| Horizontal Spacing            | 10 characters per inch   |
| Parallel Data Input Connector | 40-pin PC edge connector   |
| Code                          | Standard US ASCII-2  |
| Character Set                 | 96 US ASCII alpha-numeric character codes.   |
| Input Character Format        | 8 parallel data bits.  |
| Input Data Rate               | Up to 9300 characters/second.  |
| Input Voltage/Frequency       | 120 VAC $\pm$ 10% 60 Hz  |
| Power Requirements            | 100 watts  |
| Size                          | 14-1/2"W x 11"D x 5"H; (368 mm) x (279 mm) x<br>(127 mm)   |
| Weight                        | 12 lbs. (5.4 Kg)   |

## SETTING UP

### INSPECTION

Visually inspect the printer for signs of damage received during shipment. Notify the common carrier immediately of any discrepancies.

### NOTE

Any attempt to operate a damaged printer voids the warranty and may cause further damage.

### QUICK SET-UP PROCEDURES

1. Install roll paper holder and roll paper, fanfold paper, or single-sheet paper.
2. Remove top cover and check ribbon, then reinstall cover and install top paper guide. Ensure that head restraint and ribbon cover packing has been removed.

### CAUTION

When turning power on or off, the RESET ON/OFF switch should always be placed in the ON position to prevent erroneous communications between the host device and the printer and to prevent damage to the printer.

3. Place POWER switch in the OFF position and place RESET ON/OFF switch in ON position.
4. Connect power cord to a 3-wire, grounded AC outlet.
5. Connect interface cable to printer interface connector.
6. Place POWER switch in ON position and observe that the LED illuminates through paper exit slot.
7. Place RESET ON/OFF switch in OFF position to receive data.

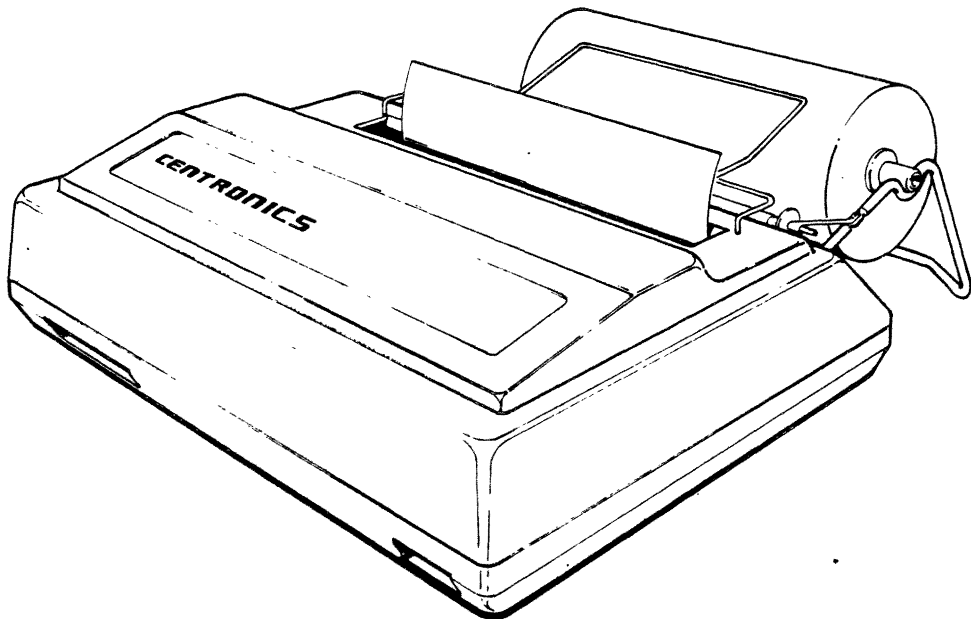

Figure 1. MODEL 730-1 PRINTER

## ROLL PAPER HOLDER INSTALLATION

1. Set the printer on a flat surface with enough room in back of the printer for the roll paper holder.
2. Refer to Figure 2 and squeeze the support arms together slightly.
3. Insert support arms into two holes provided at rear of printer and release support arms.
4. Remove core hub from plain end and insert roller through standard 1-inch paper roll core and place roll on holder as shown with paper feeding from bottom of roll.

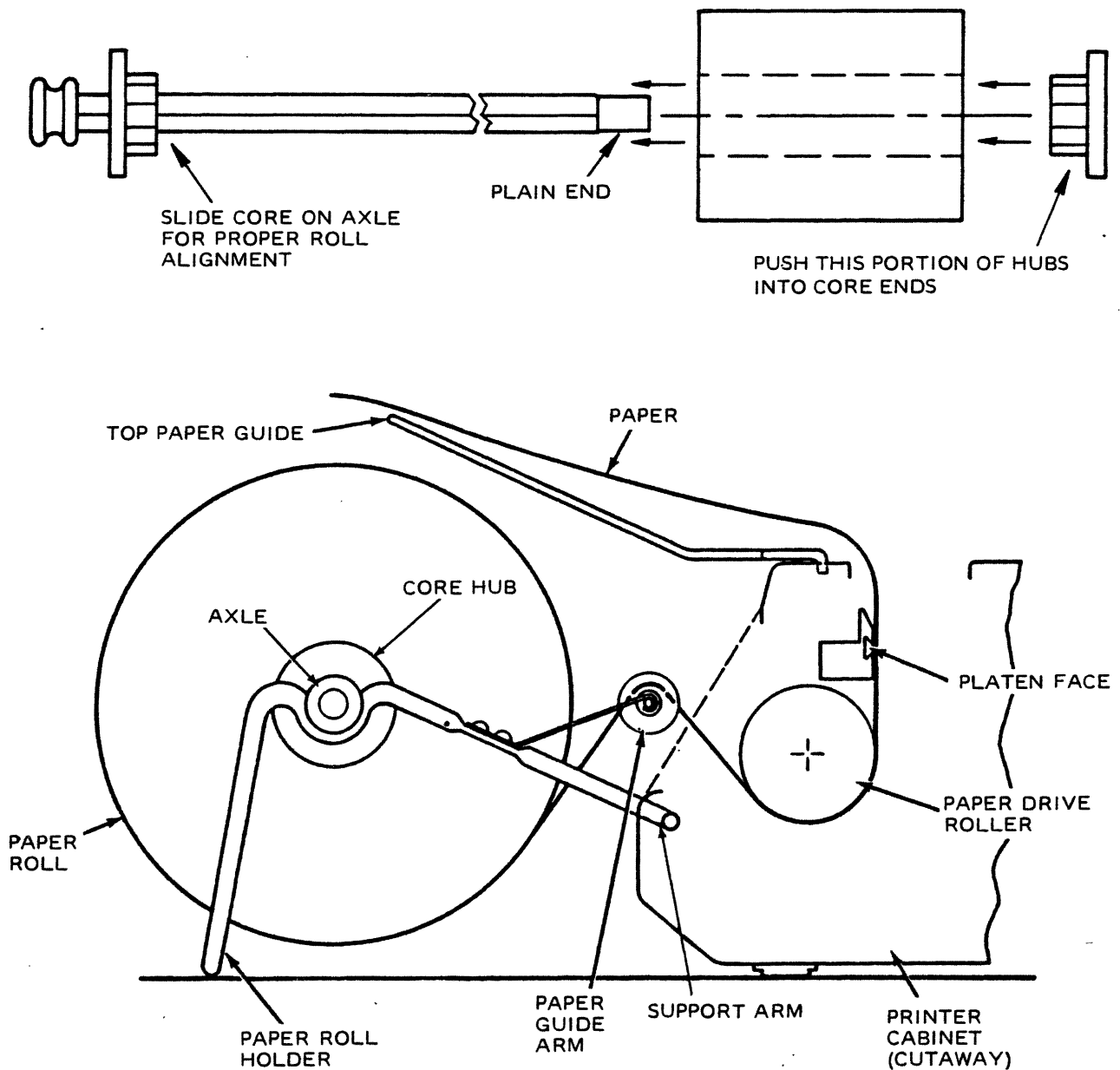

Figure 2. ROLL PAPER HOLDER INSTALLATION

## PAPER INSTALLATION

### Printer Forms Selection Guide

The printer has the unique ability to handle three common types of paper; cut sheet, roll, and fanfold. Line registration can vary depending on the type of paper being used. To select the ideal type of paper or form for your application, you should consider the following guidelines:

1. Precise registration, 6 lines to the inch, can be best maintained by using continuous fanfold edge-punched paper. This type of paper should be used wherever registration is critical such as in preprinted forms applications.
2. The last line can be printed up to 1.6" (40.6 mm) from the bottom of the page when using cut sheet paper.
3. In pinch-feed applications when using roll paper or cut-sheet paper, the line spacing can vary depending upon the finish and weight of the paper. Check the paper for your application before use or procurement of preprinted forms.

Refer to the appropriate procedure to install roll paper, fanfold paper, or single sheets/forms.

#### NOTE

When installing ribbon or paper, always back print head away from platen.

## Roll Paper

1. Install the roll on the paper holder as described previously.
2. Remove top cover by lifting rear edge until latches are clear of main cover and then slide cover back to disengage front clips.
3. Retract head to the paper/ribbon load position by rotating head release lever fully counterclockwise.
4. Push the pinch-roller release lever towards rear of printer.
5. Feed the paper over the paper guide arm and through the bottom rear of the printer under the paper drive roller.
6. Align the edges of the free end of paper with paper-drive roller edges and straighten as required.
7. Remove any skew between paper roll and the paper-drive roller by sliding the roll on the holder axle to align the paper as shown in Figure 3.

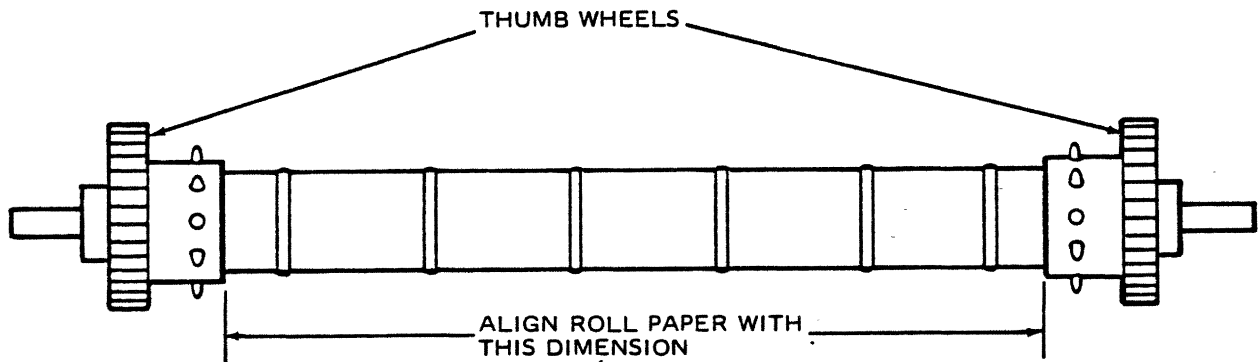

Figure 3. PAPER DRIVE ROLLER

8. Push the pinch-roller release lever forward to secure paper.
9. Advance paper into printer by turning either thumbwheel until paper exits through the top of the printer.
10. Check ribbon position, remove slack if necessary, move head-release lever to print position, and install top cover. Print position numbers on print head assembly indicate head-release lever positions for number of plies of paper as a general rule. Note that print-head position may vary depending upon type of paper being used.



### Fanfold Paper

1. Remove the top cover, retract head and make sure release lever is in down position (open).
2. Engage paper onto pins of paper-drive roller at bottom rear of printer.
3. Hold paper in place while turning either thumbwheel until the paper exits through the top of the printer.
4. Be sure the paper supply is feeding properly.
5. Check ribbon position, remove slack if necessary; move head-release lever to appropriate print position and install top cover. Print position numbers on print head assembly indicate head release lever positions for number of plies of paper as a general rule. Note that the print-head position may vary depending upon type of paper being used.

#### NOTE

When using pinfeed type paper, the pinch roller release lever should be left in the down position (away from printer). This provides more positive drive by the feed pins and prevents imprinting on second and third copies of multipart paper caused by pressure of the paper-drive roller rings on the carbon paper between the copies.

### Single Sheets/Forms

1. Push pinch-roller release lever towards rear to the open position.
2. Insert top edge of sheet/form through opening in the rear of the printer under the paper drive roller.
3. Slide sheet/form into rear of printer under paper-drive roller until sheet/form rises through paper-exit slot.
4. Match up top and bottom edges of paper. Straighten paper as required.
5. Pull pinch-roller release lever forward to closed position.
6. Manually turn two thumbwheels until sheet is in position for the first printed line.

## RIBBON INSTALLATION

Zip-Pack ribbons are used with the printer. The procedure for installing the ribbon is as follows:

1. Remove printer top cover to gain access to ribbon tray.

### NOTE

Use the throwaway plastic gloves provided with the new ribbon when performing the following steps.

2. Retract the head by rotating the head-release lever fully counterclockwise.
3. Refer to Figure 4 and push the driven roller away from the drive roller and unthread the old ribbon and discard it.
4. Remove the Zip-Pack from the plastic bag.
5. Place Zip-Pack in printer tray as shown in Figure 5.
6. Pull ribbon out from both ends of Zip-Pack and thread according to ribbon threading diagram, being careful to position mobius loop twist on the left side (See Figure 4).
7. Hold ribbon in place by pressing down on plastic strip through hole in shell piece and then remove wrapper by pulling end of wrapper.
8. Remove and discard shell and plastic strip.
9. Manually advance drive roller clockwise until slack is removed from ribbon.
10. Engage head and install top cover.

### RIBBON SPECIFICATIONS

The printer uses a 180° mobius loop ribbon configuration that allows printing on upper and lower portions of the ribbon on alternate passes, thereby increasing ribbon life. The specifications are as follows:

|            |  |
|------------|--|
| LENGTH:    | 20 yards (18.3 meters)                                   |
| WIDTH:     | 9/16 inch $\pm$ 1/64 inch (14.3 mm $\pm$ 0.4 mm)         |
| THICKNESS: | 0.0004 inch $\pm$ 0.00025 inch (0.01 mm $\pm$ 0.0064 mm) |

Ribbons may be obtained from Centronics in packages of one dozen. The part number for a package is 63701648-6003. The ribbon color is black.

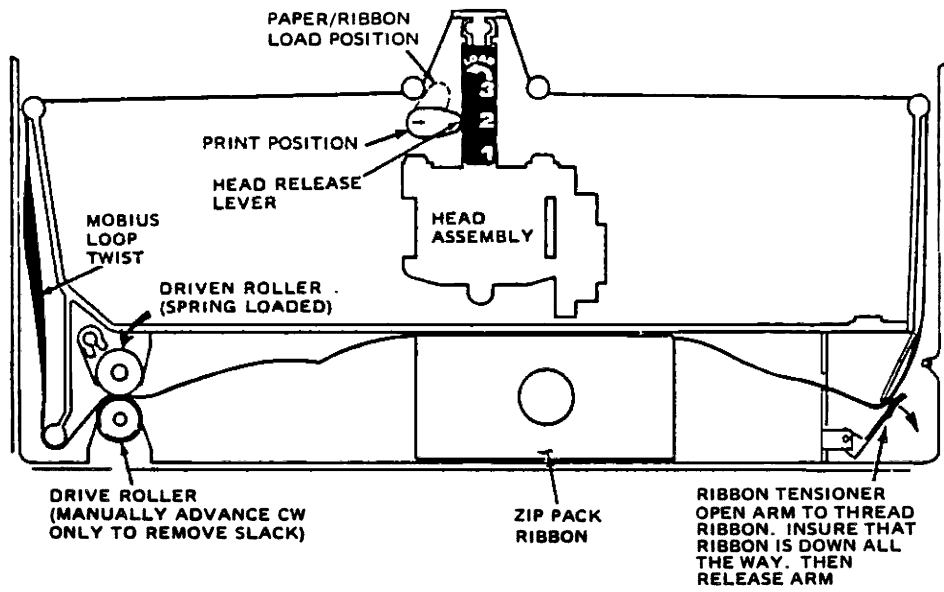

Figure 4. RIBBON THREADING DIAGRAM

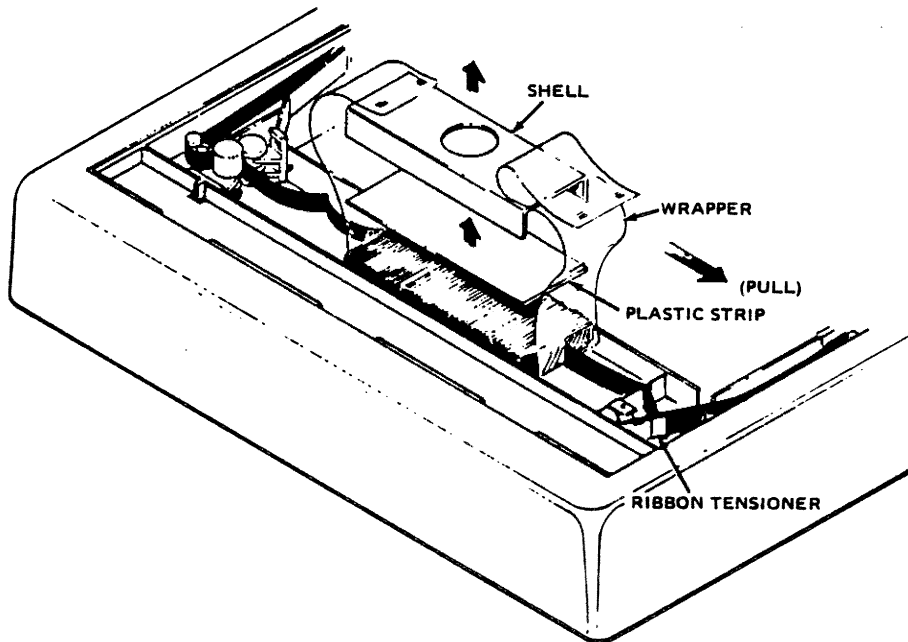

Figure 5. ZIP-PACK INSTALLATION DIAGRAM

## OPERATION

### USING THE PRINTER

1. Be sure that a ribbon is installed in the printer and an adequate supply of paper has been installed.
2. Place RESET ON/OFF switch in the ON position. (Refer to Figure 6.) This prevents the printer from printing and keeps it "off-line".

### CAUTION

When turning power on or off, the RESET ON/OFF switch should always be placed in the ON position to prevent erroneous communications between the host device and the printer and to prevent damage to the printer.

3. Place POWER ON/OFF switch in ON position. "Power On" LED should be visible through paper-exit slot.
4. Place RESET ON/OFF switch in the OFF position. Printer is ready to accept data.
5. To turn printer off, place RESET ON/OFF switch in ON position. Then, place POWER ON/OFF switch in OFF position.

### HINTS AND TIPS

- Always plug printer into a 3-wire grounded outlet.
- Do not leave or place objects on any part of printer.
- Do not subject printer to temperatures below +40°F (4°C) during operation, to a sudden change in temperature, to dust, or to extreme shock.
- Use only a dry, soft cloth to clean printer surfaces. Do not use harsh detergents or chemicals.
- Avoid touching print-head print wires when handling paper or changing ribbons.
- Periodically clean ink build-up from ribbon guide path and remove paper dust from interior.

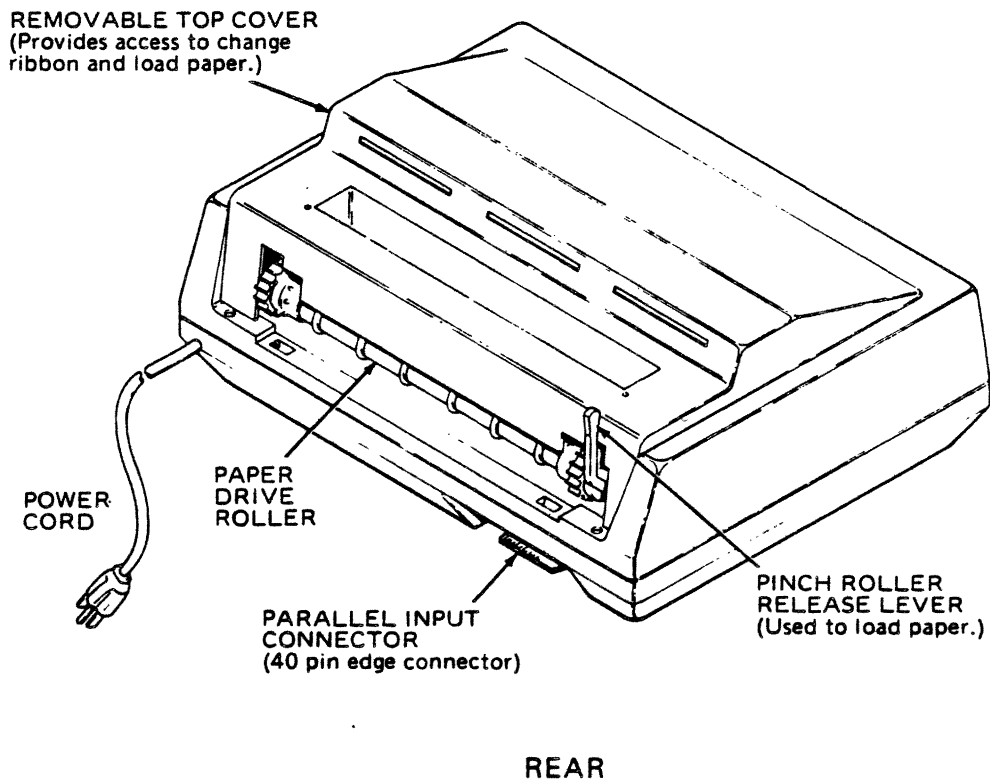
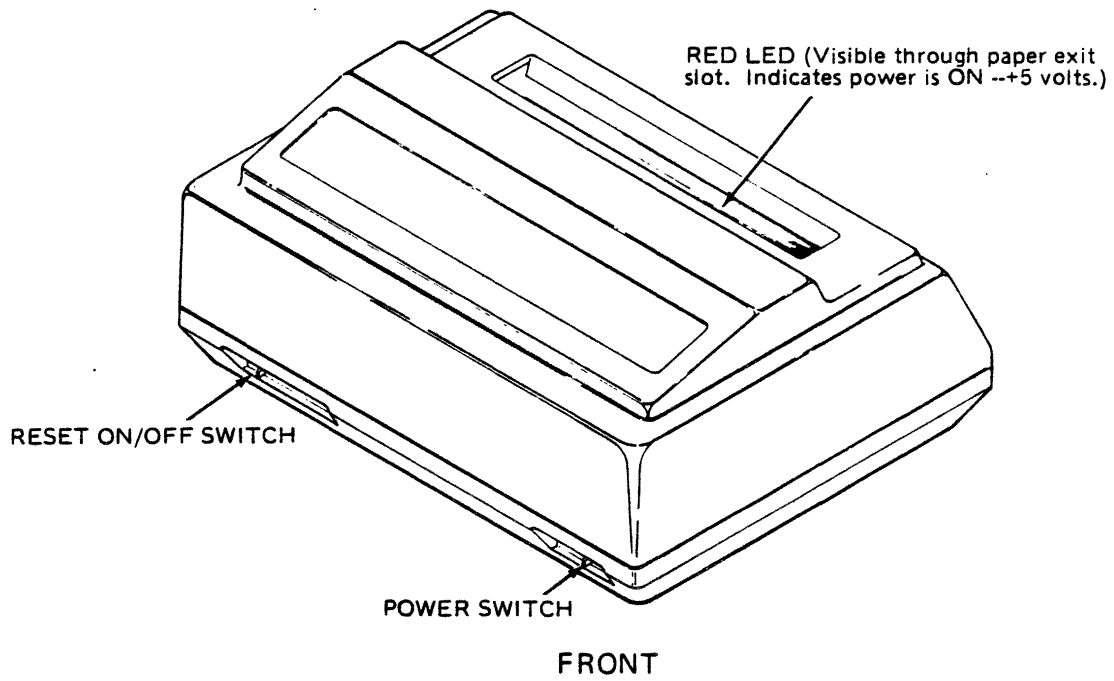

Figure 6. OPERATOR CONTROLS

## PRINCIPLES OF OPERATION

All logic, control, drive, and power supply circuits are contained on one printed circuit board within the printer (Figure 10). The print head is mounted on a carriage assembly driven by a DC motor. Printing is performed in the forward direction only (left to right), printing up to seven dots per column. The paper drive roller is driven by a line feed solenoid which advances paper one line (1/6 inch) each time the line feed solenoid is actuated. The ribbon drive motor (AC) moves ribbon past the print head at all times except when the carriage assembly actuates the sensor at the leftmost carriage position. The power supply provides +5V regulated, +5V EXT SENSE for host device sense, +12V regulated for motor drive, +17 for solenoid drive, and +24 VAC for the ribbon drive motor.

The host device transmits 8-bit parallel (US ASCII) data signals and a data strobe signal to the printer logic. Control of the transfer of data is achieved using the busy, demand, and acknowledge signals generated by the printer logic.

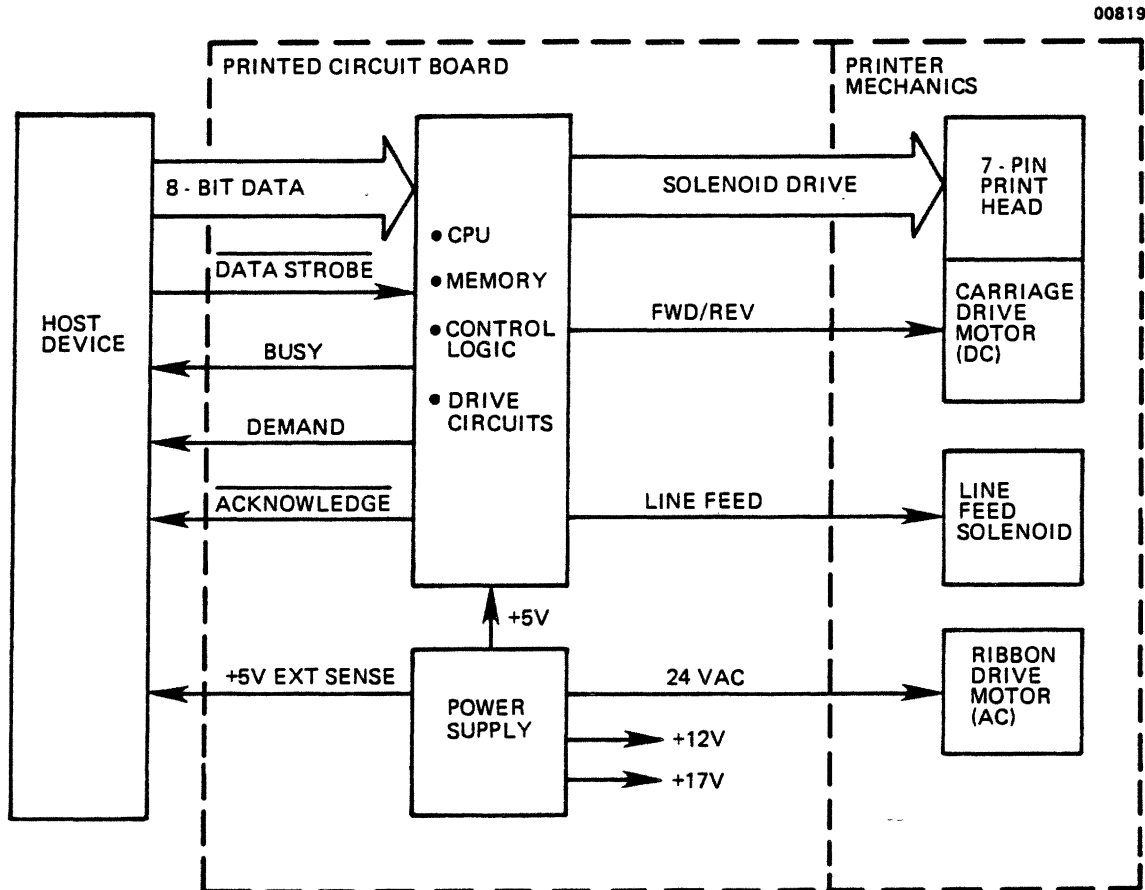

Figure 7. 730-1 PRINTER BASIC BLOCK DIAGRAM

The printer accepts and stores input character data in an 80-character holding buffer until either the buffer is filled or a carriage return (CR) control code is received. If the buffer is filled or a CR code is received, the content of the holding buffer is printed. Printing of the characters is achieved by energizing solenoids in the print head which drive circular pins against the ribbon, paper, and platen as the print head is moved by the carriage drive motor forming the characters in a 7x7 dot-matrix pattern. Upon completion of printing the print head is moved to the left margin and the paper is advanced one line by energizing the line feed solenoid.

Line feed (LF) control codes received by the printer control paper movement. Each line feed code received causes the paper to be advanced one line. The printer has a special line feed buffer, separate from the holding buffer, which can store up to 255 line feed commands. LF control codes are received at the same data transfer rate as character data (up to 9300 characters per second). The initial LF code causes an immediate advance of one line. Additional line feed codes received are stored as a count in the line feed buffer. Line feed codes and character data sent to the printer may be intermixed, however, all line feeds received are performed before printing the next line of data.

Automatic line feed upon completion of printing each line may be disabled by removing resistor R34 on the printer logic printer circuit board. If this function is disabled, the first line of data will be printed when a CR control code is received or a buffer full condition occurs. After printing the first line of data, the print head is returned to the left margin and the paper is not advanced. The second line (and subsequent lines) of data must have at least one LF control code precede each CR control code or buffer full condition, or overprinting will occur.

Line feed codes may be used for limited paper handling functions. Each line feed code moves the paper one-sixth of an inch. Thus, for example, if it is desired to move the paper 12 inches, 72 line feed codes are required before a CR control code is sent.

Elongated characters can be printed which are double width characters formed by printing each column of dots within each character twice. Spaces between characters are also twice as wide. This effectively halves the number of characters per inch (cpi) from 10 cpi to 5 cpi. Figure 8 shows the normal and elongated character styles.

Elongated characters are initiated by using the escape code ESC, SO code sequence (or data bit 8 logically high) and terminated by the escape code ESC, SI code sequence (or data bit 8 logically low). Elongated characters are automatically terminated at the end of a line. Reception of an ESC SO code sequence causes all data following the code sequence to be printed elongated. Control code sequence ESC, SI causes all data following the code sequence to be printed normal size. Elongated characters may be initiated and terminated any number of times within a line. The end of a print line terminates printing of elongated characters, and unless elongated characters are initiated by the ESC, SO code sequence preceding the data for the next line, the characters in the next line will be printed normal size.

Figure 9 shows the printer interface timing. Each set of data bits (1-8) sent to the printer is strobed by the DATA STROBE signal sent to the printer by the host device. Within 50 nsec following the trailing edge of the DATA STROBE signal a BUSY signal is generated by the printer which is sent to the host device. The BUSY signal informs the host device that the printer is processing the input data and that no additional data from the host device will be accepted by the printer. After completion of processing the input data an acknowledge (ACK) signal is sent to the host device indicating that the data sent by the host device has been accepted and processed. Within 50 nsec following the leading edge of the ACK signal the BUSY signal is terminated indicating that the printer is again ready to accept additional input data. A DEMAND signal is also generated by the printer and is available to the host device. The DEMAND signal is the inverse of the BUSY signal and when present (positive) indicates that the printer is not busy and is ready to accept data.

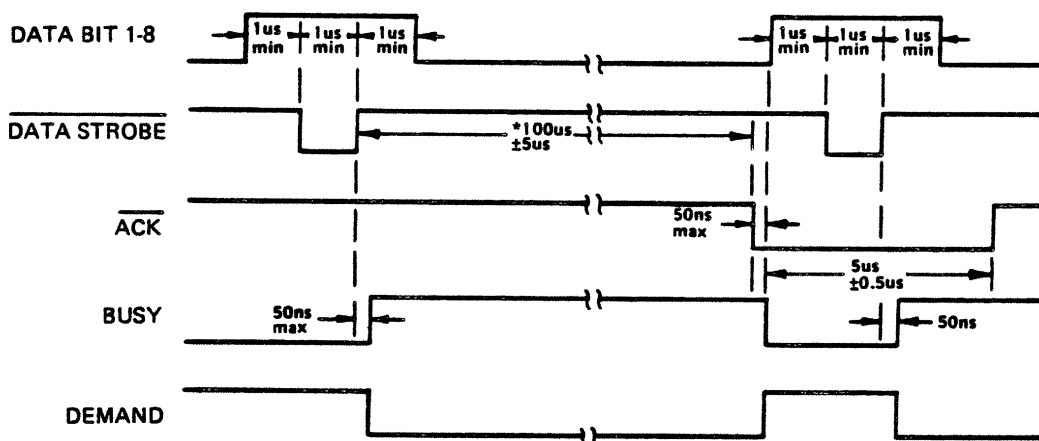

\* 100 usec is for data reception and line feeds that do not fill the line feed buffer. For line feeds that fill the buffer, the time is 110 msec +10%, -0%. For carriage return codes, the maximum time is 2.6 seconds. In approximately 10% of the data transfer cycles (strobe to ACK cycles) a microprocessor interrupt occurs which extends the busy time from a nominal 100 usec to approximately 200 usec.

Figure 9. INTERFACE TIMING

The time between the trailing edge of the DATA STROBE signal and the leading edge of the ACK signal (data transfer cycle time) varies with the functions to be performed by the printer. For normal data inputs and LF control codes which do not fill the line feed buffer, the duration is nominally 160 usec. For LF control codes which fill the line feed buffer, the maximum time is 110 msec +10, -0%. The maximum time for carriage return codes is 2.6 seconds. In approximately 10% of the normal data transfer cycles a microprocessor interrupt occurs which extends the time from a nominal 100 usec to approximately 200 usec.

Figure 10 shows the acknowledge timing on power-up. When power is initially turned on, approximately 20 msec is required for internal voltages (+5V) to stabilize. Within 30 msec after power is turned on the BUSY signal is generated and the printer remains in the BUSY condition for the next 170 msec. The BUSY signal is then terminated and the printer generates the first acknowledge pulse indicating that the printer is no longer BUSY, is on line, and is ready to accept data. Data should not be sent to the printer until the first ACK signal is sent to the host device.



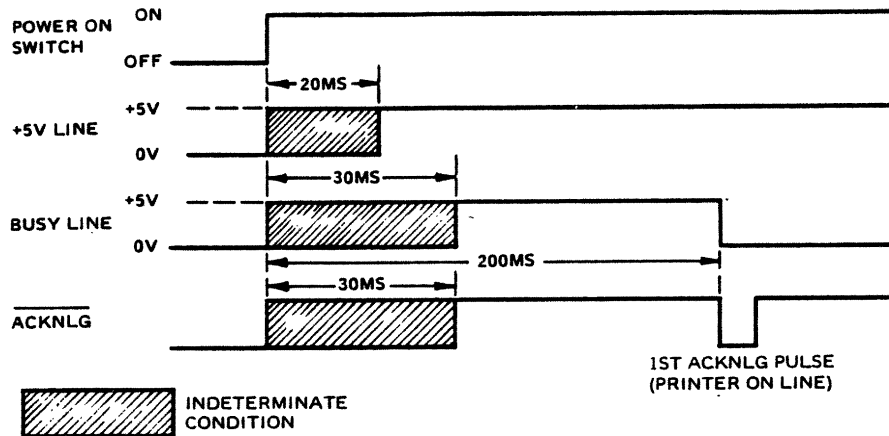

Figure 10. ACKNOWLEDGE TIMING ON POWER-UP

The Power ON/OFF switch controls the application of primary power to the printer. When power is turned on, an LED visible through the paper exit slot indicates that the +5 volts is active. The RESET ON/OFF switch controls the printer modes of operation. When placed in the ON position, the printer is placed in a local mode of operation, a BUSY signal is sent to the host device, the printer electronics are reset, and the print buffer is cleared. When placed in the OFF position, the printer electronics are reset, the print head is returned to the left margin, and the BUSY signal is discontinued allowing data to be sent by the host device. If the switch is placed in the ON position when the printer is processing a line of data, the printer will complete printing the line of data, return the print head to the left margin, then reset the printer electronics and clear the print buffer. If the printer is performing multiple line feeds at the time when the switch is placed in the ON position, the line feed operation currently being performed will be completed and the remaining line feeds will be processed when the printer is returned to the on-line mode. The RESET ON/OFF switch should be placed in the ON position when turning power to the printer on or off as extraneous acknowledge (ACK) signals can occur during the periods when power is initially turned on or off.

**CAUTION**

Actuation of the On Line/Off Line switch results in loss of data contained in the print buffer.

## PRINTER INTERFACE

### PRINTER INTERFACE CONNECTIONS

#### Printer Interface Connector

A 40-pin printed circuit edge card connector located at the left rear of the printer provides the means for connecting the printer to an input device. A mating connector for preparing a customer supplied interface cable may be procured from Centronics (Part No. 31230032). Two alternate sources of mating connectors are 3M (Part No. 3464-0001) and T&B Ansley (Part No. 609-4015M.) The physical and electrical characteristics, pin orientation, and connector pin-outs of the printer interface connector are shown below.

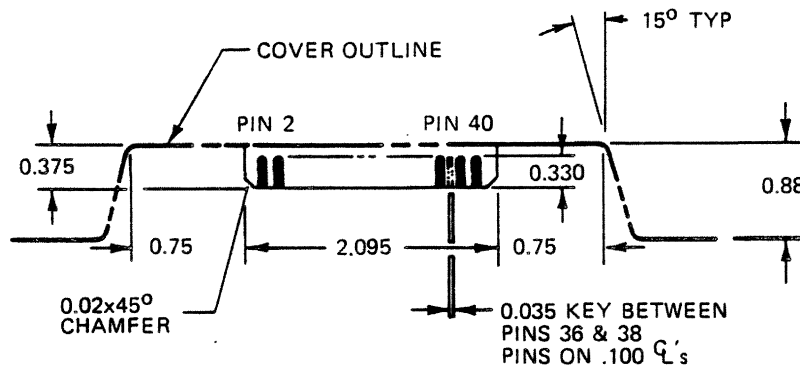

Figure 11. TOP VIEW OF PRINTER INTERFACE CONNECTOR

#### PRINTER INTERFACE CONNECTOR PIN-OUTS

| PIN | SIGNAL                   | PIN | SIGNAL                                     |
|-----|--------------------------|-----|--|
| 1   | <u>DATA STROBE</u>       | 2   | TWISTED PAIR GROUND ( <u>DATA STROBE</u> ) |
| 3   | DATA BIT 1               | 4   | TWISTED PAIR GROUND (DATA BIT 1)           |
| 5   | DATA BIT 2               | 6   | TWISTED PAIR GROUND (DATA BIT 2)           |
| 7   | DATA BIT 3               | 8   | TWISTED PAIR GROUND (DATA BIT 3)           |
| 9   | DATA BIT 4               | 10  | TWISTED PAIR GROUND (DATA BIT 4)           |
| 11  | DATA BIT 5               | 12  | TWISTED PAIR GROUND (DATA BIT 5)           |
| 13  | DATA BIT 6               | 14  | TWISTED PAIR GROUND (DATA BIT 6)           |
| 15  | DATA BIT 7               | 16  | TWISTED PAIR GROUND (DATA BIT 7)           |
| 17  | <u>DATA BIT 8</u>        | 18  | TWISTED PAIR GROUND ( <u>DATA BIT 8</u> )  |
| 19  | <u>ACKNOWLEDGE (ACK)</u> | 20  | TWISTED PAIR GROUND ( <u>ACKNOWLEDGE</u> ) |
| 21  | BUSY                     | 22  | TWISTED PAIR GROUND (BUSY)                 |
| 23  | ALWAYS LOGIC 0 (GROUND)  | 24  | TWISTED PAIR GROUND (DEMAND)               |
| 25  | ALWAYS LOGIC 1 (+5V)     | 26  | NOT USED                                   |
| 27  | SIGNAL GROUND            | 28  | ALWAYS LOGIC 1                             |
| 29  | NOT USED                 | 30  | GROUND                                     |
| 31  | SIGNAL GROUND            | 32  | PIN 32 JUMPED TO PIN 34                    |
| 33  | CHASSIS GROUND           | 34  | FOR SENSING PRINTER CONNECTED              |
| 35  | +5V SIGNAL (P.S. ON)     | 36  | DEMAND                                     |
| 37  | NOT USED                 | 38  | NOT USED                                   |
| 39  | NOT USED                 | 40  | NOT USED                                   |

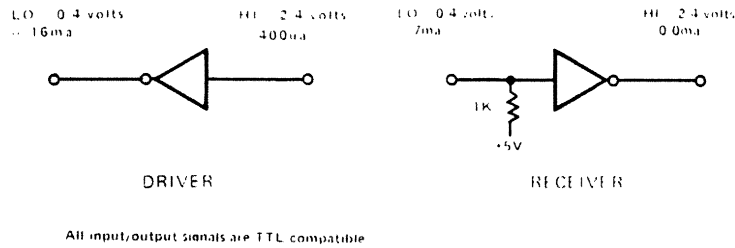

Figure 12. INTERFACE DRIVERS AND RECEIVERS

### INPUT/OUTPUT SIGNAL DESCRIPTIONS

#### Data Strobe (Host Generated)

The data strobe (DATA STROBE) signal is a negative going pulse which is used to transfer the incoming data from the host into the electronic circuitry of the printer. The pulse duration must be a minimum of one microsecond. The relationship of the leading and trailing edges of the DATA STROBE signal with the leading and trailing edges of the input data signals must be as shown in the interface timing diagram (Figure 9).

#### Data Lines (Host Generated)

The eight input data lines provide the means to transfer bits 1 through 8 of the US ASCII character data and control code data. The presence of logic one bits is indicated by positive going signals.

#### Acknowledge (Printer Generated)

The acknowledge (ACK) signal is a negative going signal which indicates that the printer has processed the latest data transferred from the host. No new data can be sent to the printer until the leading edge of the ACK pulse has occurred. If the printer receives a carriage return (CR) control code, or if the printer print buffer or line feed buffer becomes full, the acknowledge pulse will not occur until after the line has been printed or until the line feed buffer becomes only partially full.

#### Busy (Printer Generated)

The BUSY signal is a positive going signal which indicates the time when the printer cannot accept new data. The BUSY signal goes positive on the trailing edge of every data strobe pulse and remains high until the leading edge of the acknowledge pulse. No new data can be sent to the printer while the BUSY signal is high.

#### Demand (Printer Generated)

The DEMAND signal is the inverse of the BUSY signal. When high (positive), the DEMAND signal indicates that the printer can accept data.

#### +5V Signal (Printer Generated)

The +5V signal (I/O Connector, Pin 35) indicates that the +5V power supply is operating in the printer. The +5V signal is intended to be used for signal purposes only and it must not be used to provide power to external equipment.

## HOST-GENERATED CONTROL CODES

Control code data is sent to the printer along with character code data via the input data lines. Control codes are sent as data, but are interpreted as instructions by the printer. The following is a summary of the control codes and control code sequences recognized by the printer. Each of the control codes is described in detail in the following paragraphs.

| <u>Mnemonic</u> | <u>Decimal</u> | <u>Octal Code</u> | <u>Hex Code</u> | <u>Function</u>            |
|-----------------|----------------|-------------------|-----------------|----------------------------|
| LF              | 10             | 012               | 0A              | Full Line Feed Forward     |
| CR              | 13             | 015               | 0D              | Print Command              |
| ESC SO          | 27, 14         | 033, 016          | 1B, 0E          | Start Elongated Characters |
| ESC, SI         | 27, 15         | 033, 017          | 1B, 0F          | Stop Elongated Characters  |

### Line Feed (LF) Code

Each line feed (LF) code received by the printer causes the paper to be advanced one line. Line feed codes are received at the same rate as character data (up to 9300 characters per second.) When multiple line feed codes are sent to the printer, the initial line feed code is acted upon immediately and the additional line feed codes are stored in the line feed buffer as a count. If more than 255 lines feeds are received the printer will go busy, and no more data can be sent to the printer until pending line feeds have been processed and the line feed buffer is partially full. Line feed codes and character data can be intermixed, however all line feeds in the buffer will be processed before the next line is printed.

### Carriage Return (CR) Code

The carriage return (CR) code serves as a print command to the printer. Data is received by the printer and stored in the print buffer until a CR code is received. Upon receipt of a CR code, the contents of the print buffer is printed. If the print buffer is filled, a CR code is generated by the printer and the line is printed. The print head is returned to the left margin after the content of the print buffer is printed.

### ESC, SO; ESC, SI Code Sequence and Data Bit 8 Control

The ESC, SO code sequence (or bit 8 logically high) initiates printing of elongated characters (doublewidth characters.) The ESC, SO code sequence may be sent to the printer at any time during the transmission of a line of character data (up to 40 characters.) Reception of an ESC SI code sequence (or bit 8 logically low) causes all data following the code sequence to be printed normal size. The end of a print line terminates printing of elongated characters. The next line of data will be printed as standard-width characters unless an ESC, SO code sequence is received during the transmission of the character data for that line.

US ASCII CODE CHART

Figure 13 is a US ASCII code chart which shows the standard 96 US ASCII characters which may be printed by the 730-1 printer, the codes for the various characters, and the control codes recognized by the printer.

| Bits |    |    |    |    | Column          |                 |                 |                 |                 |                 |                 |                 |   |   |   |
|------|----|----|----|----|-----------------|-----------------|-----------------|-----------------|-----------------|-----------------|-----------------|-----------------|---|---|---|
|      |    |    |    |    | 0 <sub>00</sub> | 0 <sub>01</sub> | 0 <sub>10</sub> | 0 <sub>11</sub> | 1 <sub>00</sub> | 1 <sub>01</sub> | 1 <sub>10</sub> | 1 <sub>11</sub> |   |   |   |
| b7   | b6 | b5 | b4 | b3 | b2              | b1              | Row             | 0               | 1               | 2               | 3               | 4               | 5 | 6 | 7 |
| 0    | 0  | 0  | 0  | 0  | 0               | 0               | 0               | NUL             | DLE             | SP              | 0               | @               | P | ↓ | p |
| 0    | 0  | 0  | 0  | 1  | 1               | 0               | 1               | SOH             | DC1             | !               | 1               | A               | Q | a | q |
| 0    | 0  | 0  | 1  | 0  | 1               | 0               | 2               | STX             | DC2             | "               | 2               | B               | R | b | r |
| 0    | 0  | 0  | 1  | 1  | 1               | 0               | 3               | ETX             | DC3             | #               | 3               | C               | S | c | s |
| 0    | 1  | 0  | 0  | 0  | 0               | 0               | 4               | EOT             | DC4             | \$              | 4               | D               | T | d | t |
| 0    | 1  | 0  | 0  | 1  | 0               | 1               | 5               | ENQ             | NAK             | %               | 5               | E               | U | e | u |
| 0    | 1  | 0  | 1  | 0  | 1               | 0               | 6               | ACK             | SYN             | &               | 6               | F               | V | f | v |
| 0    | 1  | 0  | 1  | 1  | 0               | 1               | 7               | BEL             | ETB             | '               | 7               | G               | W | g | w |
| 1    | 0  | 0  | 0  | 0  | 0               | 0               | 8               | BS              | CAN             | (               | 8               | H               | X | h | x |
| 1    | 0  | 0  | 0  | 1  | 0               | 0               | 9               | HT              | EM              | )               | 9               | I               | Y | i | y |
| 1    | 0  | 0  | 1  | 0  | 0               | 0               | 10              | LF              | SUB             | *               | :               | J               | Z | j | z |
| 1    | 0  | 0  | 1  | 1  | 0               | 0               | 11              | VT              | ESC             | +               | ;               | K               | [ | k | { |
| 1    | 1  | 0  | 0  | 0  | 0               | 0               | 12              | FF              | FS              | ,               | <               | L               | \ | l |   |
| 1    | 1  | 0  | 0  | 1  | 0               | 0               | 13              | CR              | GS              | -               | =               | M               | ] | m | } |
| 1    | 1  | 0  | 1  | 0  | 0               | 0               | 14              | SO              | RS              | .               | >               | N               | ↑ | n | → |
| 1    | 1  | 0  | 1  | 1  | 0               | 0               | 15              | SI              | US              | /               | ?               | O               | ← | o | ⚡ |

Indicates Control Codes Recognized By Model 730-1 Printer.

CONTROL CODES
  STANDARD

Figure 13. US ASCII CODE CHART

## MAINTENANCE

### PREVENTIVE MAINTENANCE

Routine preventive maintenance should be performed at regular intervals to insure satisfactory performance of the printer. Preventive maintenance consists of periodic cleaning, inspection, and lubrication. The recommended preventive maintenance and suggested frequencies are shown below. Preventive maintenance may be required more or less frequently than indicated depending upon the printer application, operating environment, and type of paper/forms used.

### WARNING

When performing preventive maintenance procedures, the POWER ON/OFF switch must be in the OFF position and the AC input plug must be disconnected. High voltages are present in some locations within the printer when the printer is turned OFF.

### PREVENTIVE MAINTENANCE

| <u>ITEM</u>                      | <u>FREQUENCY</u>   | <u>PROCEDURE</u>   |
|----------------------------------|--------------------|--|
| External Cleaning                | As Required        | Clean all external surfaces using a mild detergent and a soft, clean, lint-free cloth.   |
| Internal Inspection              | Each Ribbon Change | Visually inspect interior of printer for loose wires, connectors, and hardware, chafing of cables, and badly worn or damaged parts.  |
| Print Head and Carriage Assembly | Each Ribbon Change | After removing ribbon, use a light-bristle brush to carefully remove dust and residue from print head and carriage assembly.   |
| Print Head                       | Each Ribbon Change | Using a soft, clean, lint-free cloth, gently remove all dried ink from the front of the print head.  |
| General Cleaning                 | 6 Months           | Perform all of the above procedures. Clean the platen surface using a mild detergent and water, and a soft, lint-free cloth. Using a vacuum cleaner with a soft brush attachment carefully vacuum interior of printer taking care not to damage printer. |

PREVENTIVE MAINTENANCE (cont'd)

| <u>ITEM</u>         | <u>FREQUENCY</u> | <u>PROCEDURE</u>  |
|---------------------|------------------|---|
| Carriage Guide Bars | 6 Months         | Move print head to left side of printer. Apply several drops of lubricating oil to clean, lint-free cloth and lightly rub carriage guide bars to remove any build-up of residue. Move print head to right side of printer and repeat procedure.                     |
| Paper Drive Roller  | 6 Months         | Using a lint-free cloth, clean the paper drive roller and plate bushings. After cleaning, apply one drop of light lubricating oil to both paper roller end plate bushings. Cycle the paper roller using the thumbwheels to allow the oil to seep into the bushings. |

TROUBLESHOOTING

The troubleshooting chart below lists some malfunctions which may occur, the probable causes, and the remedies. If the equipment remains inoperative after performing the remedies indicated, the equipment should be serviced by qualified service personnel. Note that the warranty is voided if attempts to repair the printer result in further damage.

WARNING

When performing troubleshooting procedures, the POWER ON/OFF switch must be in the OFF position and the AC input plug must be disconnected. High voltages are present in some locations within the printer when the printer is turned OFF.

TROUBLESHOOTING CHART

| <u>TROUBLE</u>  | <u>PROBABLE CAUSE</u>                            | <u>REMEDY</u>  |
|---|--|--|
| Print too light.                                      | Print head release lever open or partially open. | Rotate print head release lever clockwise to normal printing position. |
|   | Worn or defective ribbon.                        | Replace ribbon.  |
| Roll Paper/Cut-sheet paper does not advance properly. | Pinch roller release lever in open position.     | Pull pinch roller release lever forward to closed position.            |

TROUBLESHOOTING CHART (cont'd)

| <u>TROUBLE</u>  | <u>PROBABLE CAUSE</u>   | <u>REMEDY</u>  |
|---|---|--|
| Ribbon does not feed properly.                        | Ribbon twisted or im-<br>properly loaded.                     | Check ribbon threading and<br>correct as required.   |
|   | Ribbon drive rollers not<br>engaged properly.                 | Open and release driven<br>roller. Rotate driven<br>roller clockwise to assure<br>proper movement of ribbon.     |
| Printer completely<br>inoperative.                    | AC input plug not<br>connected.                               | Connect AC input connector<br>to power source.   |
|   | Paper jam.  | Remove power and carefully<br>clear paper jam. Check<br>condition of ribbon before<br>returning power.           |
|   | Fuse F1 blown.  | Check if "Power On" LED<br>is lit by looking down<br>through paper exit slot.<br>If not lit, replace fuse<br>F1. |
| Power applied/data<br>sent-printer does<br>not print. | Cable between input de-<br>vice and printer not<br>connected. | Check that connectors at<br>both ends of data input<br>cable are properly<br>connected to mating<br>connectors.  |
|   | RESET ON/OFF switch in<br>ON position.                        | Place switch in OFF position.  |



## DISASSEMBLY OF COVER ASSEMBLIES

In order to replace fuse F1 or to disable the auto line feed on carriage return function it is necessary to disassemble the cover assemblies. Refer to Figure 14 and proceed as follows:

1. Place POWER ON/OFF switch in OFF position and disconnect AC input plug from power source. Disconnect data input connector.
2. Remove top cover by lifting rear edge until latches are clear of body cover and then slide cover towards rear of printer to disengage front clips.
3. Unthread the ribbon from the print head carriage assembly, then take up slack in ribbon by turning ribbon drive roller knob clockwise.
4. Release the two Phillips-head screws at the front of the printer and the three Phillips-head screws at the rear of the printer using a No. 1 Phillips screwdriver.
5. Gradually raise the body cover until there is enough room to reach under the front of the cover.
6. Reach under the body cover and disconnect the ribbon drive motor cable connector from connector J002 on the logic PC board.
7. Keep the body cover level to prevent ribbon from unthreading and set cover to one side.
8. To reassemble printer, reverse procedure.

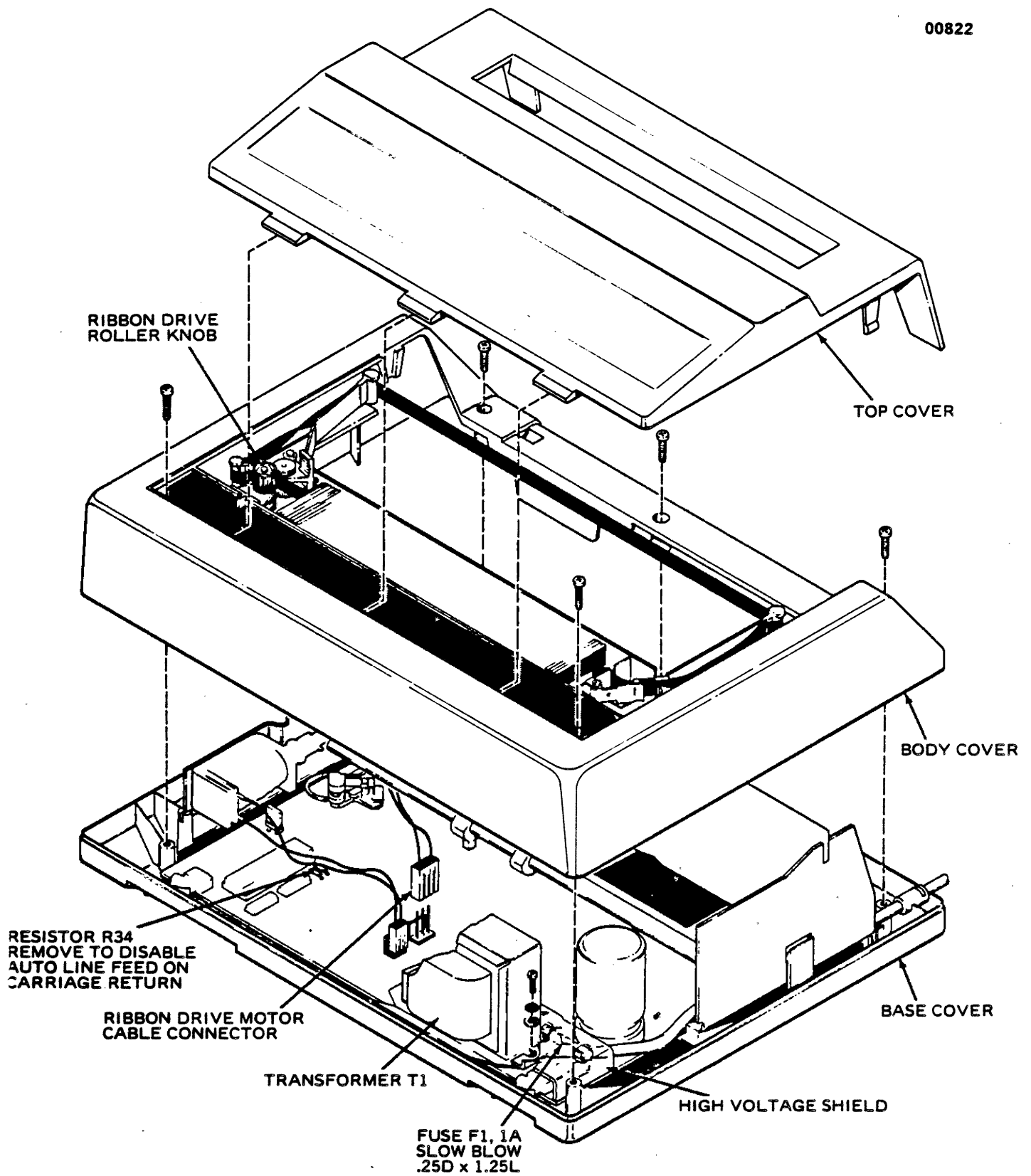

Figure 14. DISASSEMBLY OF PRINTER COVER ASSEMBLIES

## FUSE REPLACEMENT

Fuse F1 is located on the forward right-hand corner of the logic P.C. board adjacent to the power transformer and POWER ON/OFF switch. Refer to Figure 14 and proceed as follows:

1. Disassemble cover assemblies to gain access to logic P.C. board mounted on the base cover. (See procedure for disassembly of cover assemblies.)
2. Loosen screw, located on right side of transformer using a Phillips screwdriver.
3. Remove the clear plastic high voltage shield covering the fuse and AC input circuits.
4. Remove and replace the defective fuse.
5. Reinstall the high voltage shield. Make sure that the slotted portion of the shield is under the flat washer.
6. Tighten the Phillips-head screw to secure the shield and transformer.
7. Reassemble the cover assemblies.

## DISABLING OF AUTO LINE FEED ON CARRIAGE RETURN

The auto line feed on carriage return function may be disabled by removing resistor R34 on the logic P.C. board. To disable this function, refer to Figure 14 and proceed as follows:

1. Disassemble cover assemblies to gain access to logic P.C. board mounted on base cover. (See procedure for disassembly of cover assemblies.)
2. Locate resistor R34 and cut the lead that is most distant from the large IC chip, using side cutters.
3. Bend resistor upward away from P.C. board and cut second resistor lead.
4. Reassemble the cover assemblies.

The auto line feed on carriage return function may be re-enabled by installing a new resistor (R34, 270 ohms, 1/4 watt). Use a 25 to 35 watt soldering iron and wicking braid or a solder sucker to remove old solder. Then, solder the new resistor in place. Before installing the resistor, trim and form leads so they do not extend more than 1/8 inch through the printed circuit board.

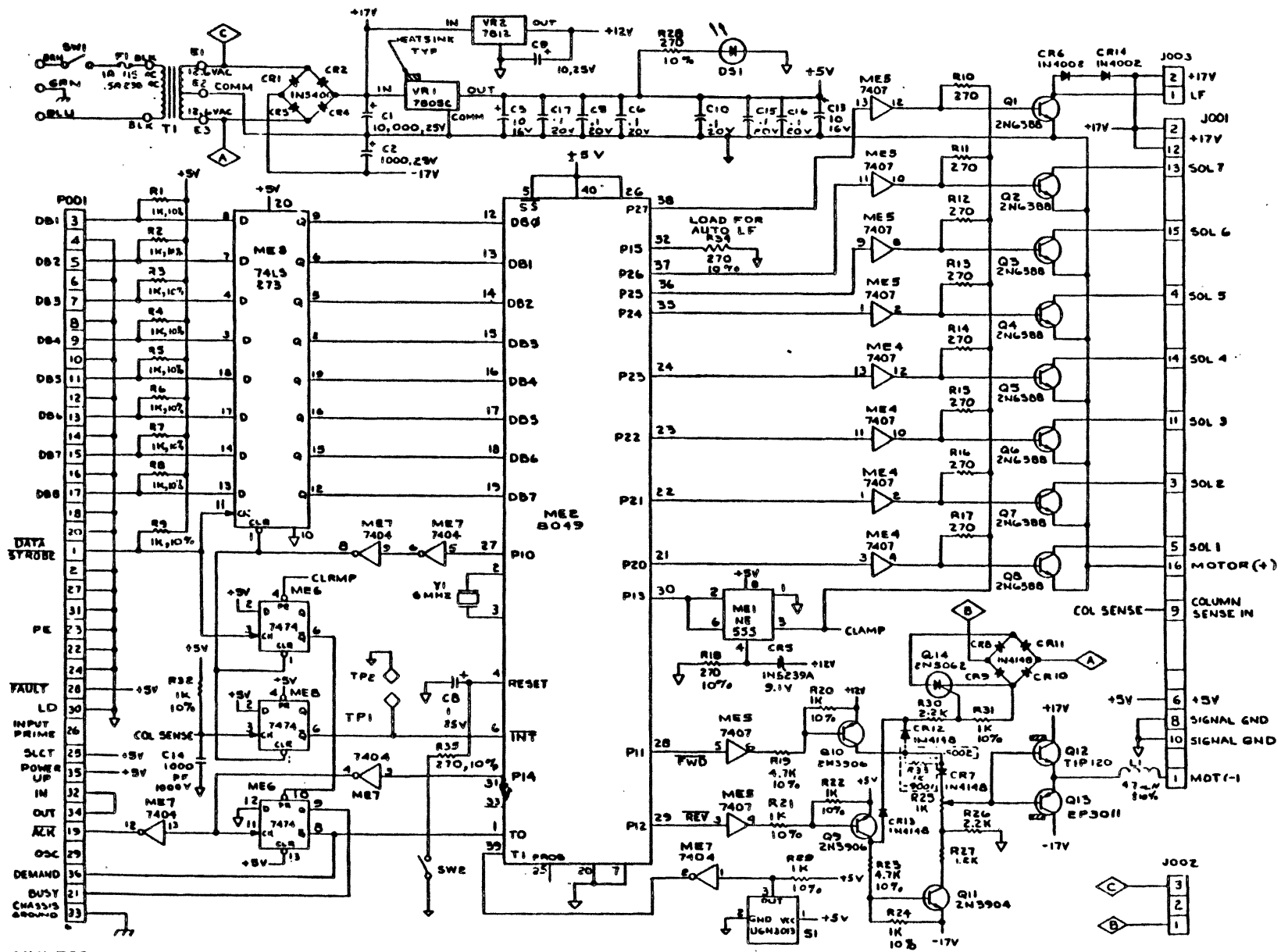

UNLESS OTHERWISE SPECIFIED...  
CAPACITANCE IN µf; RESISTANCE IN Ω ¼W ± 5%;

HALL EFFECT SENSOR  
FOR RTP

Figure 15. MODEL 730-1 PRINTER SCHEMATIC DIAGRAM