

**Adaptec**

**ACB-232XD User's Manual**

## TABLE OF CONTENTS

Section	Page
1.0 INTRODUCTION	1
1.1 Quick Installation	1
1.2 Scope and Purpose of Manual	1
1.3 Reference Documents	1
1.4 Overview of Product	2
1.5 Hardware and Software Requirements	4
2.0 HARDWARE INSTALLATION	5
2.1 Introduction	5
2.2 Environmental Requirements	5
2.3 Unpacking Procedure	5
2.4 ACB-2322D Board Layout	5
2.5 System Requirements	7
2.6 Integration Into the System	8
3.0 SOFTWARE INSTALLATION	13
3.1 Introduction	13
3.2 Format Procedure for Hard Disk Drives	14
3.3 Special Options	17
4.0 TROUBLESHOOTING	20
4.1 Introduction	20
4.2 Adaptec ACB-232XD Troubleshooting Checklist	20
4.3 Controller Error Codes	21
4.4 BIOS Error Codes	23

## LIST OF TABLES

Table	Page
2-1. ACB-232XD System Memory Map	7
2-2. ACB-2322D Controller Power Requirements	7
2-3. ACB-2320D Controller Power Requirements	7
2-4. ACB-232XD Controller Connector Definitions	8
4-1. Class 00 Error Codes (Drive Errors)	21
4-2. Class 01 Error Codes (Data Recover Errors)	22
4-3. Class 02 error Codes (System-Related Errors)	22
4-4. Class 03 Error Codes (Diagnostics Errors)	22
4-5. Class 04 Error Codes (Timeouts and Misc. Errors)	23
4-6. BIOS Error Codes	23

## LIST OF FIGURES

Figure	Page
2-1. ACB-2322D Board Layout	5
2-2. ACB-2322D Controller and Drive Cabling (Twisted Cable)	11
2-3. ACB-2322D Controller and Drive Cabling (Flat Cable)	11

## 1.0 INTRODUCTION

### 1.1 Quick Installation

Most of us don't like to read manuals. If you are familiar with drive installations, you don't need to read this one. The manual describes in detail the process outlined below. Try this quick-install first. If you need more details, dig into the manual.

- a. Install controller and drives into your PC AT, and cable them together. (ACB-2322D only) Run a floppy cable from the "Floppy Cable" connector (J5) to both floppy drives. The connector on the END of the cable goes to drive 0. Run a 34-pin hard drive cable from (J4) "HD CONTROL CABLE" and connect to both hard drives. Connect one 20-pin cable each from "DRIVE 0" (J3) to the first hard drive, and from "DRIVE 1" (J2) to the second hard drive (if installed). Don't forget to plug a system power cable into the hard drive!
- b. Run your PC AT "SETUP" and set the hard drive to type 1.
- c. Boot to DOS, and run DEBUG.
- d. Type in:  
A:\>DEBUG  
<CR>  
-G=C800:5  
<CR>
- e. The Adaptec format menu will come up.
- f. Choose: 1 - to primary-format drive 0.
- g. The controller will read the number of heads and cylinders from the drive. The manufacturer's defect list will also be read in.
- h. Now just keep hitting <CR> (to take the defaults).
- i. After format is complete, choose q - to end the program.
- j. Now you are ready to install your operating system software. Go to DOS FDISK, and FORMAT, or SPEEDSTOR, DISK MANAGER, SCO XENIX, OS/2, UNIX, etc.

### 1.2 Scope and Purpose of Manual

The purpose of this manual is to guide the system integrator through a successful installation of Adaptec's ACB-232XD board. This includes both hardware and software installation, as well as basic troubleshooting information.

### 1.3 Reference Documents

- \* IBM PC AT Guide to Operations Manual
- \* IBM DOS Reference Manual Version 3.0 or Higher
- \* IBM PC AT Technical Reference Manual
- \* Appropriate Disk Drive User's Manual

## 1.4 Overview of Product

The Adaptec ACB-232XD is a series of high-performance ESDI Hard Disk and Floppy Disk Controllers for the IBM PC AT and equivalent personal computers.

- \* The ACB-2320D is an ESDI hard disk controller.
- \* The ACB-2322D is an ESDI hard disk and floppy disk controller.

The ACB-232XD is software and hardware compatible with the IBM PC AT hard disk controller interface.

The Adaptec ACB-232XD ESDI Controllers have the following features:

- \* IBM hardware compatible. Plugs directly into AT bus compatible systems without modification. Register (port) compatible to the IBM AT controller, giving true compatibility.
- \* IBM software compatible. Runs software that communicates through the AT system BIOS or directly to the controller registers, thus, the highest AT compatibility is achieved.
- \* Supports two enhanced small disk interface (ESDI) drives. Runs hard-sectored 10, 15 and 20 MHz ESDI drives from all major ESDI manufacturers. Supports two drives that are different capacity, different access time and different manufacturers without controller modification. Drives with up to 16 heads and 4096 cylinders are supported by the controller through the registers. Provides both the highest capacity and highest performance.
- \* Highest AT ESDI performance. The combination of non-interleaved operation and low controller overhead give the ACB-232XD the highest transfer rate available today. This is from 900 Kilobytes per second to as high as 1.9 Megabyte per second data transfer depending on system configuration.
- \* Non-interleaved operation. This gives the ability to read one track of data in one disk revolution, the maximum rate that the drive can give data to the controller. This provides the fastest controller/drive performance.
- \* Can support more than 1024 cylinders under DOS. Breaks the INT 13, 1024 cylinder, limit. Drives up to 528 MBytes can be supported by translating the cylinder count.
- \* Can support up to 1 Gigabyte under DOS. Adaptec's drive-splitting feature allows one large physical drive to be split into two "logical" drives and run as a C & D drive under DOS without installing driver software.
- \* Sector-sparing. One sector per track can be reserved as a spare. If a defect is found during format, the track will be re-formatted using the spare. Then the drive will be defect free under DOS.
- \* 17 sector translation. The controller can emulate a 17 sector format for software such as Novell that requires that feature.
- \* 64 K Byte buffer. A 64 K buffer is standard on the ACB-2322D. 64K can cache a full track for the large new drives with up to 72 sectors per track; 32K cannot. Under DOS or OS/2, there can never be a host overrun condition, because their maximum request block size is 64K. Even if the host CPU is too busy to process

the data immediately, the ACB-232XD will pull it off the disk into the buffer, ready for transfer at Read-Ahead speed when the CPU comes back.

- \* Read-ahead. Special algorithms take in data before it is requested and store it, ready for lightning-fast data transfers. Up to 1.9 MByte/sec recorded on Coretest! Provides optimum performance with UNIX/XENIX.
- \* Multi-track read-Ahead. The ACB-232XD does not stop at the track boundary, but continues to read-ahead until the buffer is full. With its 64K buffer, the ACB-232XD can pre-fetch up to four full tracks.
- \* Optional on-board Adaptec ACB-BIOS. This provides the most functionality of any AT controller. The copyrighted ACB-BIOS contains the low level format, defect management, data verification, autoconfiguration of any drive without changing AT system BIOS.
- \* ACB-BIOS low-level primary format. This provides the ability on the controller to format the drive without the need of system diagnostics or changing the AT system BIOS.
- \* ACB-BIOS ability to read ESDI drive parameters. This reads the drive characteristics directly from the drive, reducing the possibility of using the wrong number of heads, cylinders, sectors, etc.
- \* ACB-BIOS ability to read ESDI manufacturer's defect list. This reads the manufacturer's flagged bad areas on the disk, eliminating the need to enter them manually.
- \* ACB-BIOS ability to add grown defects, save and protect all defect lists. This gives the ability to run additional defect tests and add the defects to those the manufacturer found. Also the controller saves and protects both the manufacturer's and grown lists from accidental erasure, thus the highest data reliability.
- \* ACB-BIOS sector -level defect mapping. This flags a sector on the disk to be unusable and reports to the operating system its location, giving system level data integrity.
- \* ACB-BIOS dynamic skewing. The BIOS determines the optimum head skew for the low-level format. This means less time lost during head switching.
- \* ACB-BIOS data verification using worst case data patterns. This tests the disk with the worst possible combinations of data before valuable user data is placed on the disk. This provides the highest data reliability.
- \* ACB-BIOS autoconfiguration of any ESDI drive, not in AT system BIOS. This allows any ESDI drive to be formatted and used without changing the AT system BIOS drive tables. This simplifies the cumbersome task of changing EPROM drive tables to add ESDI. The controller writes the drive parameters onto the drive during format and reads them on power up. This is ideal for field upgrades since the controller does not need to be hardware configured to the specific drive. This achieves the highest drive flexibility possible.
- \* Shadow RAM. The auto configuration drive tables are stored in a protected location. This enhances compatibility with VGA and all major software programs.
- \* ACB-BIOS defaults and help messages. Default entries help speed the user through an installation. If an error occurs, help messages come up to tell the user

what to do.

- \* XT height board. This allows use in both XT and AT height machines, thus giving you flexibility in choosing your machine's enclosure.
- \* High component integration using Adaptec ICs. Adaptec is committed to IC development in order to integrate and to reduce the price of both boards and ICs. Adaptec's ICs are used in all Adaptec boards and in most integrated drives on the market; therefore, Adaptec components are proven in reliability and in high volume production.
- \* Use of surface mount technology. Adaptec is committed to the leading edge of technology. Surface Mount Technology allows greater functionality in smaller spaces, as well as higher reliability and low power.

The ACB-2322D has these additional features:

- \* Support of two IBM AT-type floppy disk drives. Compatible with the most popular IBM floppy capacities. This includes 360 KB and 1.2 MB floppy capacities for 5 1/4" floppy compatibility. Also supports 3 1/2" floppies that use the 5 1/4" floppy drive interface.
- \* Floppy controller can be disabled, for use with systems that have a motherboard floppy controller.
- \* Analog floppy data separator. This gives much higher data integrity than digital data separators. Thus floppy data reliability and data retrieve ability are improved over previous AT floppy controllers.
- \* Format compatibility with the ACB-2320B/2322B, EXCEPT that the ACB-2320D/2322D does not support soft sectored drives.

## 1.5 Hardware and Software Requirements

In order to install an Adaptec ACB-232XD into an IBM PC AT-compatible computer, the following are required:

1. IBM PC AT-compatible computer.
2. PC or MS-DOS Version 3.0 or higher. System and supplemental program diskettes.

The ACB-232XD will also run with non-DOS operating systems and networks. Please refer to the appendix for operation with Interactive System Unix V/386, SCO Xenix, Novell NetWare, OS/2 and other operating systems.

3. A diagnostic program diskette that allows the PC AT-compatible computer's configuration RAM to be set up (such as the diagnostics diskette IBM supplies with its PC ATs.)
4. Adaptec ACB-2322D hard disk and floppy disk controller, or Adaptec ACB-2320D hard disk controller for systems that include a floppy controller.
5. An ESDI Winchester disk drive.
6. 5 1/4" or 3 1/2" floppy disk drive.
7. 20- and 34-pin flat or twisted ribbon cables for hard disk.



8. 34 pin twisted ribbon cable for floppy disk (ACB-2322D only).

## 2.0 HARDWARE INSTALLATION

### 2.1 Introduction

This section describes the steps necessary to install the ACB-232XD board into the computer. First, the operating environment, unpacking procedure and board layout are described. This section also describes the integration of the drive and controller into the computer.

### 2.2 Environmental Requirements

The ACB-232XD will perform properly over the following range of conditions:

	Operating	Storage
Temperature:	0ø to 55øC (32ø to 131øF)	-40ø to 75øC (-8ø to 167øF)
Humidity (Noncondensing):	0% to 95%	10% to 95%
Altitude (Feet):	Sea level to 10,000	Sea level to 20,000
MTBF (Hours):	80,000 at 55øC	

### 2.3 Unpacking Procedure

The carrier is responsible for damage incurred during shipment. In case of damage, have the carrier note the damage on both the delivery receipt and the freight bill, then notify your freight company representative so that the necessary insurance claims can be initiated.

After opening the shipping container, use the packing slip to verify receipt of the individual items listed on the slip. Retain the shipping container and packing material for possible later reuse should return of the equipment to the factory or distributor be necessary.

**CAUTION:** The ACB-232XD like all electronic equipment, is static sensitive. Please take the proper precautions when handling the board. Keep the board in its conductive wrapping until it is ready to be configured and installed in your system.

### 2.4 ACB-2322D Board Layout

The ACB-2322D is shown in Figure 2-1. This figure shows the location of the controller microcode, ACB-BIOS, jumpers and connectors. Note that Pin 1 of the connectors is identified by a square solder pad on the solder side of the board. The dimensions of the board are:

Width: 3.90 Inches  
 Length: 8.00 Inches  
 Height: 0.75 Inches

**FIGURE 2-1. ACB-2322D BOARD LAYOUT**

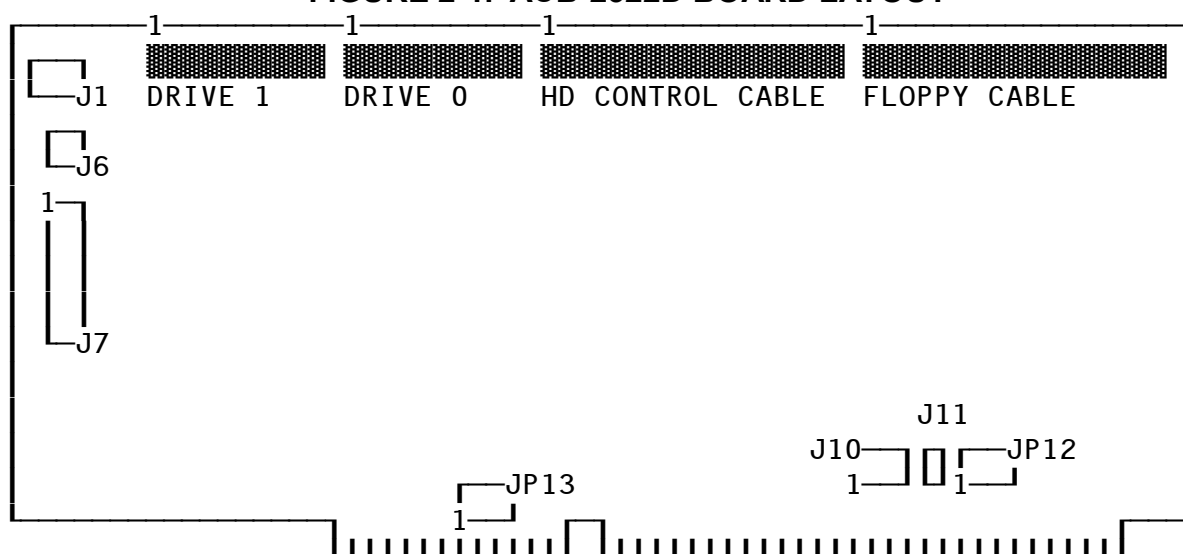

**ACB-2322D CONTROLLER JUMPER DEFINITIONS**

- J6 Not Used
- J7-1 Not Used
- J7-2 Logical Drive Splitting
  - Out = disabled\*
  - In = enabled, drive 0 split into two logical drives if over 1024 cylinders
- J7-3 Not Used
- J7-4 Not Used
- J7-5 Read Ahead Cache
  - Out = Enabled\*
  - In = Disabled, no read ahead performed (e.g. with NetWare, UNIX/XENIX, and OS/2 applications).
- J7-6 Not Used
- J7-7 Not Used
- J10-1 Hard Disk Port Address
  - Out = 1F0-1F7\*
  - In = 170-177 (most systems only support 1F0-1F7)
- J10-2 Floppy Disk Port Address
  - Out = 3F0-3F7\*
  - In = 370-377 (most systems only support 3F0-3F7)
- J10-3 Floppy Disk Disable
  - Out = Floppy enabled\*
  - In = Floppy disabled
- J11-1 Floppy Drive Speed
  - Out = Single speed\*
  - In = Dual speed (this is generally never used)

## ACB-2322D CONTROLLER JUMPER DEFINITIONS (CONTINUED)

J12	BIOS Address BIOS ADDRESS	Jumper number		
		1	2	3
	C8000*	out	out	out
	CC000	in	out	out
	D0000	out	in	out
	D4000	in	in	out
	Disabled	out	out	in
	D8000	in	out	in
	DC000	out	in	in

J13 Hardware Interrupt Select  
 1-2 IRQ 14\*  
 2-3 IRQ 15 (most systems only support IRQ 14)

\* = default jumper setting

## 2.5 System Requirements

The ACB-232XD was designed to be installed in an IBM PC AT-compatible personal computer; thus, it requires the same system resources as the IBM AT hard disk controller.

**TABLE 2-1. ACB-232XD SYSTEM MEMORY MAP**

		I/O Ports
Hard Disk	- Primary	1F0,1F1,1F2,1F3,1F4,1F5,1F6,1F7,3F6,3F7
	- Secondary	170,171,172,173,174,175,176,177,376,377
*Floppy Disk	- Primary	3F2,3F4,3F5,3F7
	- Secondary	372,374,375,377
If the BIOS is enabled:		BIOS Address
	- Primary	16 Kbytes C8000H- CBFFFFH
	Alternates	16 Kbytes CC000H-CFFFFH
		16 Kbytes DO000H-D3FFFFH
		16 Kbytes D4000H-D7FFFFH
		16 Kbytes D8000H-DBFFFFH
		16 Kbytes DC000H-DFFFFH

The drive tables are pointed to by Int 41 and Int 46.

\*ACB-2322D only

**TABLE 2-2. ACB-2322D POWER REQUIREMENTS  
(Typical)**

+5V Power ----->	0,870 Amp
-5V Power ----->	Not Used
+12V Power ----->	Not Used
-12V Power ----->	Not Used

**TABLE 2-3. ACB-2320D POWER REQUIREMENTS  
(Typical)**

+5V Power ----->	0,670 Amp
-5V Power ----->	Not Used
+12V Power ----->	Not Used
-12V Power ----->	Not Used

CAUTION: The values for the power requirements were determined by actual measurements in an IBM PC AT while the controller was reading a hard disk. If these values are to be used to design the controller into a specific application, at least 20% should be added to these listed values as a safety margin.

## 2.6 Integration Into the System

To install the Adaptec ACB-232XD board into your system, you must first configure the drive(s), set the controller jumpers, and connect the drive cables properly. This section describes all the necessary steps to successfully install this hardware.

### Step 1 Controller Jumper Setup and Definition

Before the Adaptec ACB-2322D can be used, some initial setup may be required. Figure 2-1 defines, in detail, connectors and jumper blocks for the ACB-2322D.

### Step 2 Hard Disk Cabling, Drive Selection and Termination

The drive changeable parameters that must be set are the drive selection switches (or jumpers) and the drive termination. The drive selection switches and cabling select the address (drive address 0-3 ) to which the drive will respond. This is accomplished either by setting both drives to be the second lowest address and using a twisted 34-pin cable, or by setting the drive addresses to 0 and 1 and using a flat cable.

#### A. Twisted 34-Pin Cable

The typical AT 34-pin cable has three connectors. Between the first (middle) drive connector (for drive D) and the second drive connector (for drive C) wires 25 through 29 are twisted, thus inverting the drive selection wires. This type of twisted cable allows both drives to have their drive selection switches (or jumpers) to be the same. Both drives must be set to the SECOND lowest drive address. The controller will see the two drives to be drive 1 and drive 2, depending on the position of the connector that is used.

#### B. Flat 34-Pin Cable

In some cases a 34-pin flat (non-twisted) cable is used. This cable does not invert the drive selection wires but relies on the drive addresses to be unique for each drive. Now drive 0 must have its drive selection switches (or jumpers) set to be the lowest drive address (typically 0). Drive 1 must have its selection switches (or jumpers) set to be the second lowest drive address (typically 1). The controller will see the two drives to be drive 0 and drive 1, independent of the position on the connector that is used.

#### C. Terminator

Before the drives can be cabled to the controller, the drive cable terminator must be properly set. The terminator is used to reduce signal "ringing" in the cables. The terminator, as its name implies, must be at the end of each cable in order to have the controller and drive communicate properly. The controller has a permanent terminator built into it. The disk drives, since they can be connected in a daisy-chain configuration, have a removable terminator. This is usually a 16-pin DIP resistor package located on the drive PCB. The last physical drive in the chain must always have its terminator installed. When two drives are connected to the same controller, only the last one in the daisy chain is terminated. The other drive must have the terminator resistor removed.

Now select the proper drive addresses and remove or install the required terminators for your system.

#### Step 3 (ACB-2322D Only) Floppy Disk Cabling, Drive Selection and Termination

The typical AT 34-pin floppy disk cable has three connectors. Between the first (middle) drive connector (for drive B) and the second drive connector (for drive A) wires 10 through 16 are twisted, thus inverting the drive selection wires. This type of twisted cable allows both drives to have their drive selection switches (or jumpers) to be the same. Both drives must be set to the SECOND lowest drive address (typically 1 since floppy drives are addressed as 0-3). The controller will see the two drives to be drive 0 and drive 1, depending on the position of the connector that is used.

Termination of the floppy disk drives is the same as the hard disk drives in step 2.

**FIGURE 2-2. ACB-2322D CONTROLLER AND DRIVE CABLING-TWISTED CABLE**

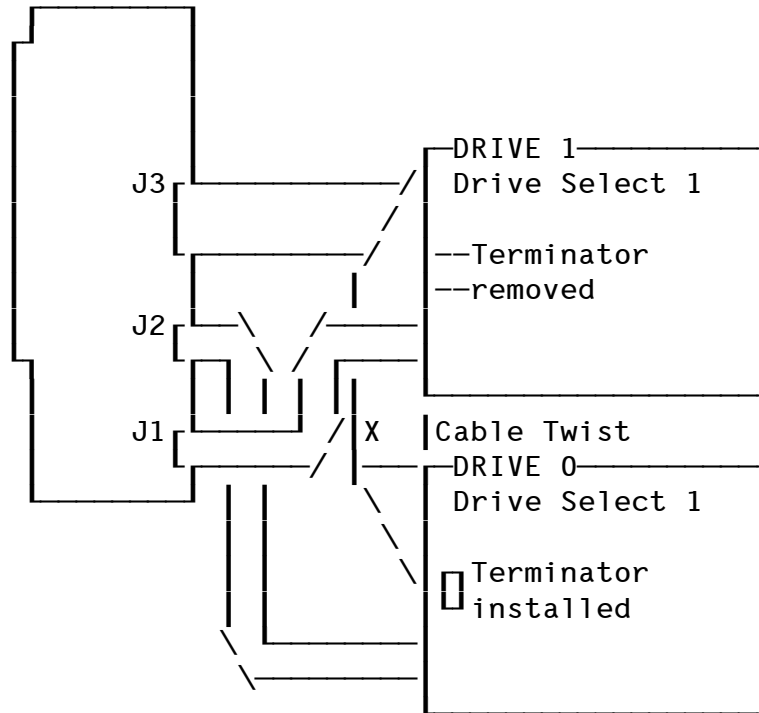

**FIGURE 2-3. ACB- 2322D CONTROLLER AND DRIVE CABLING-FLAT CABLE**

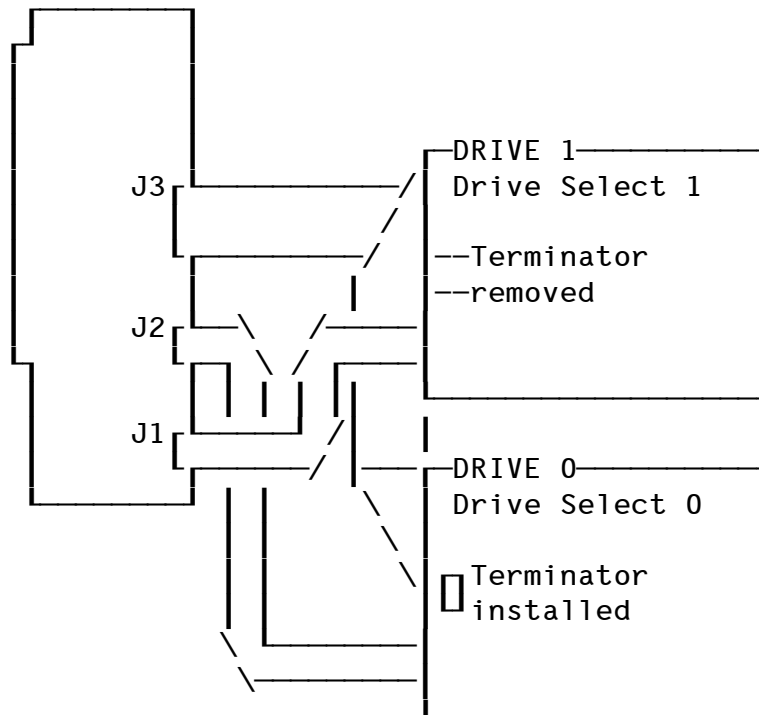

## Step 4 Mounting the Drives and Controller in the PC AT

Now that the drives and controller are configured, they can be connected and installed in the system.

The controller has four cable connectors: J2, J3, J4, and J5. Their function, suggested connector plugs and maximum cable length are described in Table 2-4.

**TABLE 2-4. ACB-2322D CONTROLLER CONNECTOR DEFINITIONS**

Connector	Signals	Cable
J5	Control/Data	34-pin flat ribbon cable. Connected to both floppy drives 0 and 1.
J3	Data	20-pin flat ribbon cable. Connected to ESDI drive 0.
J2	Data	20-pin flat ribbon cable. Connected to ESDI drive 1.
J4	Control	34-pin flat ribbon cable. Connected to both ESDI drives 0 and 1.
Connector	Recommended Plug	Maximum Length
J5	3M Part #3414	20 feet (6 meters)
J3	3M Part #3421	20 feet (6 meters)
J2	3M Part #3421	20 feet (6 meters)
J4	3M Part #3414	20 feet (6 meters)

Attach the cables to the controller, making sure that the pin 1 indicator on the cable goes to pin 1 on the controller.

Now the controller must be installed into a 16-bit slot on the PC AT motherboard. Next, mount the drive(s) in any available drive bay in the AT. Consult your PC AT owner's manual for details of performing the installation of options into the motherboard expansion slots and for instructions on mounting a hard disk and floppy disk in the system.

Note: During disk initialization, if your system motherboard supports shadowing of optional ROM BIOS's, you need to disable the shadowing of the Adaptec ACB-232XD ESDI controller BIOS. This is done through your system set up routine. After disk initialization, enable the shadowing of optional ROM BIOS's.

NOTE: If your system has a VGA Monitor with Video RAM Shadowing, you may have to move the Adaptec base BIOS address from C8000 to CC000 by altering Jumper J12.

## **3.0 SOFTWARE INSTALLATION**

### **3.1 Introduction**

To prepare a new hard disk for use, you must complete the primary-format and then install your operating system.

First, the primary-format is done using Adaptec's built-in BIOS. The procedure is described in this chapter with details describing the actual menu screens. If you run into problems while attempting to perform this installation, please refer to Chapter 4, Troubleshooting.

## 3.2 Adaptec ACB-232XD Primary-Format Procedure for Hard Disk Drives

### Step 1: Setting up the PC AT configuration RAM

After you have completed the hardware installation of your ACB-232XD and hard disk drive, turn the system power switch on. Boot from the PC AT diagnostics diskette or any diskette that contains software for configuring the PC AT SETUP parameters (CMOS RAM).

Note: When booting the PC AT with an UNFORMATTED hard disk installed, the system may report a "1790" disk failure. Ignore the message, press F1 to continue.

Invoke the SETUP RAM configuration software (i.e., option four in the IBM PC AT diagnostics program). Then follow the SETUP program's menu to set up your system for one or two hard disks. Be sure to choose drive types that are a subset of the actual disk parameters. The number of cylinders indicated by the drive type specified must be less than the actual number of cylinders on your drive. For example, with the IBM PC AT, use drive type 1 (smallest available drive type) regardless of the actual drive configuration. This is necessary for proper operation of the PC AT power-on diagnostics.

After the PC AT internal configuration has been set up, reboot the system with DOS Version 3.0 or higher.

### Step 2: Use DEBUG to enter the Adaptec Disk Preparation Program.

Put a disk with a copy of DOS' DEBUG program into the floppy drive and invoke the program by typing DEBUG at the DOS prompt, then press return. At the debug prompt, type G=C800:5 and press return. This will invoke Adaptec's Disk Preparation Program.

### Step 3: Read the ESDI Drive Parameters.

Select Option 1 to primary-format the drive 1. If the drive has been previously formatted with an ACB-232XD controller, the saved cylinder and head count will be displayed. With an unformatted drive, the number of cylinders, heads and sectors are read from the ESDI drive. If the values are not correct, type N, exit the program and check your ESDI drive jumper settings.

An example of what you will see on the screen for a brand new drive is shown below.

Note: One cylinder on the drive is reserved for use by the controller. The controller automatically subtracts this cylinder from the total number of available cylinders on the drive.



~~~~~  
A:\>DEBUG <CR>  
-G=C800:5<CR>

Adaptec Disk Preparation Program V 3.1  
Copyright (c) 1989 Adaptec, Inc. All rights reserved.  
Choose: 1 - to primary-format drive 0  
          2 - to primary-format drive 1  
          3 - for the special-options menu  
          q - to quit this program

Enter your selection: 1

Drive 0 has XXX cylinders, X heads, XX sectors  
Are the above correct (Y/N): [Y]

~~~~~  
Step 4: Choose to ERASE or NOT ERASE the Adaptec Saved Defect List.

If your drive was previously formatted with Adaptec's ACB-232XD, the saved defect list will now be displayed. Normally do not erase the saved defect list. If you choose to erase, perhaps because a previous error has resulted in a false defect map, then the Adaptec saved list will be erased. The ESDI drive manufacturer's list is not erased.

Step 5: Enter Any More Defects.

Next, the program will prompt you for the drive defect format. If you have no additional defect locations to enter, then select Option 1. Otherwise, choose the defect format that matches the list of defects you wish to enter.

~~~~~  
Saved defect list (cyl/physical sector) :  
Surface 0:                   XXXX/XX       XXXX/XX  
Do you want to ERASE saved defect list (Y/N) ? N  
Please specify the format of additional defects:  
1 - No Additional Defects  
2 - Cyl/Head/RLL byte offset  
3 - Head/Cyl/RLL byte offset  
4 - Cyl/Head/Logical Sector

Enter your selection : 1  
Press <RETURN> to enter defects from the console, or  
type the defect file name :  
Enter defect at the \* prompt, (a blank line will end  
the list) :  
~~~~~

If you have entered a defect list, it will be displayed on the screen for you to verify. Note that the defect locations have been translated into cylinder/physical sector format. Surface numbers correspond to head numbers. (Choice 4 CYL/HD/LOGICAL sector, only appears with a previously formatted drive. This allows the user to add "grown" defects at a later date.)

Step 6: Select Interleave Factor.

Now select an interleave by typing the desired interleave factor (1 to 12) and pressing return. An interleave factor of one is the default.

Step 7: Allow a Spare Sector for Defects?

For example, if an ESDI format has 36 sectors on a track, this option formats with 35 sectors and uses the 36th sector as a spare. When one sector must be marked bad due to a surface defect, the spare is used instead. Then the drive appears error-free to the operating system. However, 1/36th of the drive capacity is not used. Normally, you will want to take the default [N].

Note: If you select spare-sectoring, you will not be able to use the 17 or 63 sector translation options.

If you have entered a defect list, it will be displayed on the screen for you to verify. Note that the defect locations have been translated into cylinder/physical sector format. Surface numbers correspond to head numbers. (Choice 4, CYL/HD/LOGICAL sector, only appears with a previously formatted drive. This allows the user to add "grown" defects at a later date.)

Step 8: Primary Format the Drive, Automatic Data Verification and Automatic Flagging of Bad Sectors.

Check to be sure that all of the parameters that you have entered are correct, then enter Y to continue. Enter Y to primary format the drive. The controller will now perform the primary format. The program formats the drive from high cylinder to low cylinder, marking the defects as bad sectors. After formatting each track, the program will write and verify the track with worst case data patterns. Any defective sectors found during this write/verify process that are not in the defect list will be added to the defect list. The same track is reformatted with the newly found defective sectors marked bad. The track is then written and again verified against defects. The process is repeated for every track on the drive. ECC retries are disabled during this verification.

When the controller has finished formatting the drive, you should see "Primary-Format complete!" displayed at the bottom of the screen, indicating a successful format. An example of what you should see on the screen is shown below.

Note: If the format operation does not complete properly, (i.e., Primary-Format complete! is not displayed after formatting) see Chapter 4, Troubleshooting.

~~~~~  
Total defect list (cyl/sector) :

Surface 0:  
                  145/10  208/28 (for example)

Surface 1:

Surface 2:

Surface 3:  
Interleave (1 to 12) : [1]  
Allow a spare-sector for defects (y/n) : [n]

Ready to primary-format the drive. All data in it will be lost!!

Continue (Y/N)? [Y]

Formatting and verifying drive ...

Head XX  Cyl XXXX

|                                                                                                                                |
|--------------------------------------------------------------------------------------------------------------------------------|
| Primary-Format complete !<br>Now select q to quit, and go to your Operating System installation<br>(e.g. DOS FDISK and FORMAT) |
|--------------------------------------------------------------------------------------------------------------------------------|

~~~~~  
Step 9: Choose [q] to quit Adaptec's Primary-Format program.

Step 10: Next, the operating system must be installed.

For most users, this consists of running the \*DOS programs FDISK and FORMAT. DOS 4.0, OS/2, SCO XENIX and ISC UNIX have menus that guide the user through their installation. Refer to the vendor's manual for help with installing your operating system.

\* Note: DOS 3.0, 3.1 and 3.2 have a limit of 32 MB per drive. DOS 3.3 allows a large drive to be split into 24, 32 MB partitions. DOS 4.0 allows up to 1024 MB to be used as one drive.

### 3.3 Special Options

There are several special technical options built into the ACB-232XD controller. These features are not used by most users, but are of interest to those with unusual applications. The special option menu is accessed by selecting choice 3 from the main menu.

The following menu will come up:

- Choose 1 – to enable 17-Sector translation
- 2 – to enable 63-Sector translation
- 3 – to disable translations
- q – to return to main menu

Each choice is described below.

Choices 1, 2 and 3 turn on and off two different translation modes. After any translation option is changed, a flag in the partition table is changed to make any previous partitions unusable. This means that any previous data on the drive will become inaccessible. The operating system must be re-installed onto the selected drive each time a translation option is changed. The primary-format does not need to be re-done.

#### Choice 1: 17-Sector Translation

Choice 1 allows ESDI formats to look like a 17-Sector format. This is useful for programs, such as Novell NetWare, that only use 17 sectors per track.

Note: This option does NOT mean you can use an MFM drive with this controller. Only ESDI certified drives should be run on the ACB-232XD.

To get 17-Sector translation, answer these questions on the screen.

Translate drive 0 or 1? : 0

Enable translation on drive (0)? (Y/N) : Y

Drive (0) is now in 17-Sector translation mode!

#### Choice 2: 63-Sector Translation

DOS has a limit of 1024 cylinders per drive. This option will allow use of drives with more than 1024 cylinders, up to 530 MB capacity. The drive parameters are translated to a 63-Sector equivalent.

Enable translation for drives larger than 1024 cylinders by answering the following questions on the screen.

Translate drive 0 or 1? : 0

Enable translation on drive(0)? (Y/N): Y

Drive (0) is now in 63-Sector translation mode!

#### Choice 3: Disable Translation

This option disables any translation mode currently in effect on your drive.

Answer these questions to disable translation.

Disable translation on drive 0 or 1? : 0

Disable translation on drive (0) now? (Y/N) : Y

- \* For drives larger than 528 MB, install a jumper on position 2 of J7 to enable drive splitting.

## 4.0 TROUBLESHOOTING

### 4.1 Introduction

This section describes the procedures needed to troubleshoot problems that may arise when installing the Adaptec ACB-232XD controller board. These are the most commonly found problems and are not inclusive of every application.

CAUTION: When troubleshooting problems, use the most basic system configuration; That is, one hard disk drive on the ACB-232XD and all other devices such as printers, modems, etc. removed. Once the system works for the basic configuration, add drives and devices to the system one at a time and retest after each addition.

If these procedures fail to give a solution to your problem, recheck your steps, read the entire manual, document the problem, and check with the technical support department where you bought the controller.

### 4.2 Adaptec ACB-232XD Troubleshooting Checklist

- Gets a 1790 at boot-up  
A 1790 Error is normal for an unformatted drive. Just press F1 to continue.
- Long boot time  
Some PC AT systems may continue to retry booting to the hard drive even though it has not been formatted yet. You will have to allow this re-trying to continue for up to two minutes before the system will boot to the floppy drive. Then you can proceed to Debug and format the drive.
- Can't read floppy or boot to drive A (2322D only)  
Check floppy cables; be sure J5 goes to both floppy drives. Be sure that Pin 1 on the controller is connected to Pin 1 of the drive. If only one drive is being used, only the last connector on the twisted cable should be used. A floppy cable has wires 10-16 twisted between the two drive connectors.
- Recal error, or no drive attached error  
Check the drive select jumper on hard disk drive; be sure that it is correctly set for the type of cable you are using (See Section 2.7).  
Be sure J3 goes to Drive 0, J2 goes to Drive 1, and J4 goes to both drives. Be sure that Pin 1 on the controller is connected to Pin 1 of the drive. If only one drive is being used, only J3 and J4 should be used.
- Incorrect drive parameters  
ESDI drives have jumpers for "number of sectors per track" and for "bytes per sector",

also for hard or soft sectoring. Consult your drive vendor for proper settings of these jumpers. Do not use soft sectoring.

- Miscellaneous errors, or no format routine  
Check jumpers on controller.
- Excessive defects, or fails to format  
Make sure the drive is ESDI certified. Check with the manufacturer.
- Won't boot to C  
Check to see that the SETUP program and CMOS RAM show drive type 1 is selected.
- Intermittent operation errors; or Read/Write errors  
Check that the terminator on each drive is set properly (see Section 2.6)  
Check that the power supply can support the added current required by the drive. Be sure that the +5V and +12V voltages are correct. Consult with the drive vendor for the correct drive power requirements.
- If none of the above steps cure the problem, then swap out components in this order:  
Replace the cables with a known-good set of cables.  
Swap the drive with a known-good drive.
- Swap the 232XD controller with another 232XD controller.

### 4.3 Controller Error Codes

Tables 4-1 through 4-5 specify class 00, 01, 02, 03, and 04 error codes which may be returned by the ACB-232XD. Note that the most significant bit (the address valid bit) of the one-byte error code may be set in some cases. Thus, 80-8F, 90-9F, A0-AF, B0-BF, and C0-CF are also valid errors corresponding to error codes 00-0F, 10-1F, 20-2F, 30-3F, and 40-4F, respectively.

**Table 4-1. Class 00 Error Codes  
(Drive Errors)**

Code	Error
00	No Error Occurred During Last Command
01	No Index Signal Found
02	No Seek Complete Found
03	Write Fault Found
04	Drive Not Ready
05	- Not Assigned -
06	No Track 00 Signal
07	Not Assigned
08	Seek Operation Not Yet Complete
09	- Not Assigned -
0A	Not Assigned
0B	ESDI Interface Fault
0C	ESDI Seek Fault
0D	ESDI Parity Error
0E	Bad ESDI Configuration

0F - Not Assigned -

**Table 4-2. Class 01 Error Codes  
(Data Recover Errors)**

Code	Error
10	ID ECC Error
11	Uncorrectable Data ECC Error Found
12	ID Address Mark Not Found (sector not found)
13	Data Address Mark Not Found
14	Sector Not Found (no ID errors found)
15	Seek Error (wrong cylinder)
16	No ID AM and ID ECC error (sector not found)
17	Not Assigned
18	Corrected ECC Error(s)
19	Access to Sector Flagged As Bad
1A	Format Error Detected
1B-1F	- Not Assigned -

**Table 4-3. Class 02 Error Codes  
(System-Related Errors)**

Code	Error
20	Invalid Command
21	Illegal Parameter (cyl., head, sector)
22	Not Assigned
23	Cylinder Overflow (during command)
24	Format Command With the Wrong Number of Sectors Per Track
25-2F	- Not Assigned -

**Table 4-4. Class 03 Error Codes  
(Diagnostics errors)**

Code	Error
30	Internal CPU RAM Failed
31	Controller ROM Checksum Error
32	ECC Diagnostic Failed
33	SERDES RAM Failed
34	Disk Buffer RAM Failed
35	Buffer Controller Registers Failed
36	Drive Interface IC Failed
37	Host Interface IC Failed
38	CPU Self-Test Failed
39-3F	- Not Assigned -

**Table 4-5. Class 04 Error Codes  
(Timeouts and Misc. Errors)**

Code Error

40	Data Time-Out
41	Format Time-Out
42	SERDES Time-Out
43	Selection Time-Out

#### 4.4 BIOS Error Codes

Table 4-6 specifies error codes that may be returned during format or verify.

**Table 4-6. Bios Error Codes**

Code	Error
01	Bad Command Passed to Disk I/O
02	Address Mark Not Found
04	Requested Sector Not Found
05	Reset Failed
07	Drive Parameter Activity Failed
09	Attempt to DMA Across 64K Boundary
0A	Access to Bad Sector
0B	Bad Track Flag Detected
10	Bad ECC on Disk Read
11	ECC Corrected Data Error
20	Controller Timeout
40	Seek Operation Failed
80	Attachment Failed to Respond
BB	Undefined Error Occurred
FF	Sense Operation Failed



Adaptec, Inc.  
691 South Milpitas Blvd.  
Milpitas, California 95035  
(408) 945-8600